



STRANGER THINGS

75810



CLASSIFIED

CLASSIFIÉ

SECRETO

FILE No.	011
CASE ID.	DR. MB

N° DE DOSSIER	011
RESPONSABLE	DR M.B.

N.º DE EXPEDIENTE	011
ID. DE CASO	DR. MB



HAWKINS NATIONAL LABORATORY
U.S. DEPARTMENT OF ENERGY

LEGO® Designer Justin Ramsden explains what it's like to be the LEGO creator for the Stranger Things model.

Getting to know Stranger Things

As a huge fan of Stranger Things, I was 'Upside Down' with excitement when I was asked to develop this model. Working closely with Netflix, re-watching the show multiple times and using plans from the show as a reference, we chose to re-create the Byers' House since it was such a focal point in the series.



Making the 'flip'

For this model we represented The Upside Down as an actual upside-down, darker version of the real world. From the beginning, we wanted the model to be able to 'flip' from one world to the other. This was a challenge, as LEGO bricks are best for normal stacking. We made a lot of loops on the designs of the house and the trees, so the model is not only stable in play but also really fun to build!



Building in tandem

At first glance, The Upside Down looks very similar to the real world. Once you start to build the model, however, you will notice we've added a lot of fun details that really capture the feel of this 'dark' dimension. Some of my favorite Upside Down details are the gloomy version of the 'alphabet wall', the withered plant in the living room and the smoky bars used to represent the spooky environment of this alternate world. If you had a fellow builder nearby (then much like the kids working as a team in the show), you could build the model simultaneously and discover all the fun differences between the two worlds on your building adventure.



Enjoy the model!

It was fantastic working with the LEGO® Graphic Design team (led by Crystal Marie Fontan). They created the amazing minifigures, decorations and stickers in the model, while the LEGO Element Design team (led by Jeffery Alan Davis) developed three new minifigure wig elements. We are really pleased with the finished result and hope that fans enjoy building, exploring and playing out their favorite scenes in the model!



Will
Byers



Demogorgon



Eleven



HAWKINS NATIONAL LABORATORY
U.S. DEPARTMENT OF ENERGY



Le concepteur LEGO® Justin Ramsden explique ce que c'est que d'être le créateur du modèle de Stranger Things.

Apprendre à connaître Stranger Things

Comme je suis déjà un grand adepte de Stranger Things, j'ai été « à l'envers » d'enthousiasme quand on m'a offert de concevoir ce modèle. En travaillant en étroite collaboration avec Netflix, en visionnant la série encore et encore, et en utilisant des plans de la série comme référence, nous avons décidé de recréer la maison des Byers, puisqu'il s'agit d'un point central à travers les saisons.



Passer d'un monde à l'autre

Ce modèle représente le « monde à l'envers » comme étant une version tordue et sombre du monde réel. Dès le début, nous voulions créer un modèle qui permettrait de passer facilement d'un monde à l'autre. C'était un gros défi, puisque les briques LEGO sont conçues pour être empilées normalement. Nous avons travaillé fort sur la maison et les arbres, afin que le modèle ne soit pas seulement amusant quand vient le temps de jouer, mais aussi durant sa construction !



Construire en tandem

À première vue, le monde à l'envers ressemble beaucoup au monde réel. Lorsque vous commencerez à construire le modèle, toutefois, vous pourrez remarquer que nous avons ajouté une panoplie de détails amusants qui font vraiment ressortir le côté sombre de cette autre dimension. Parmi mes détails préférés du « monde à l'envers » se trouvent la version obscure de l'alphabet sur le mur, la plante fanée dans le salon et les éléments rappelant la fumée qui montrent bien l'étrangeté qui plane sur cet autre monde. Si vous connaissez un autre constructeur, vous pourriez (comme les enfants qui forment une équipe dans la série) assembler chacun votre modèle afin de constater les différences amusantes intégrées dans les deux mondes.



Profiter du modèle !

C'était fantastique de travailler avec l'équipe de graphistes de LEGO® (dirigée par Crystal Marie Fontan), qui a créé les figurines, les décorations et les autocollants incroyables du modèle, tandis que l'équipe de conception d'éléments (dirigée par Jeffery Alan Davis) a conçu trois nouvelles perruques de figurines. Nous sommes vraiment satisfaits du résultat et espérons que les amateurs de LEGO s'amuseront en construisant le modèle et en explorant leurs scènes favorites de la série !



Will
Byers



Démogorgon



Onze



HAWKINS NATIONAL LABORATORY
U.S. DEPARTMENT OF ENERGY



Justin Ramsden, diseñador de LEGO®, habla sobre lo que significa ser el creador de un modelo LEGO dedicado a Stranger Things.

Conocer Stranger Things

Como el gran fan de Stranger Things que soy, sentí que estaba “del otro lado” cuando me pidieron que desarrollara este modelo. Luego de trabajar estrechamente con Netflix, volver a ver el show varias veces y usar los planos de producción como referencia, decidimos recrear la casa de los Byers porque es un elemento clave de la serie.



Darle la vuelta

Para este modelo, representamos el Mundo del Revés como una versión realmente invertida y más oscura del mundo real. Desde el principio, queríamos que se pudiera dar la vuelta al modelo para pasar de un mundo a otro. Era todo un desafío, ya que los bricks LEGO funcionan mejor si se apilan con normalidad. Fue necesario hacer y rehacer muchas veces el diseño de la casa y los árboles porque no sólo buscábamos un modelo estable para jugar: ¡también queríamos que fuera muy divertido de construir!



Construcción en pareja

A primera vista, el Mundo del Revés se parece mucho al mundo real. Sin embargo, cuando empieces a construir el modelo, notarás que hemos incluido muchos detalles divertidos que realmente capturan la atmósfera de esta dimensión “oscura”. Algunos de mis detalles favoritos del Mundo del Revés son la versión sombría de la “pared del alfabeto”, la planta marchita en la sala y las barras grises que sirven para representar el estremecedor ambiente de este mundo alternativo. Si construyes el modelo con un amigo (como los chicos del show cuando trabajan en equipo), podrán encargarse de un mundo cada uno y descubrir las divertidas diferencias entre ambos a lo largo de su aventura de construcción.



¡Disfruta del modelo!

Fue fantástico trabajar con el equipo de diseño gráfico de LEGO® (dirigido por Crystal Marie Fontan). Ellos crearon las extraordinarias minifiguras, las decoraciones y las calcomanías del modelo, mientras que el equipo de diseño de elementos (dirigido por Jeffery Alan Davis) desarrolló tres nuevas pelucas para las minifiguras. ¡Nos encanta el resultado final y esperamos que los fans disfruten construyendo, explorando e interpretando sus escenas favoritas!



Will
Byers



Demogorgon



Once



HAWKINS NATIONAL LABORATORY
U.S. DEPARTMENT OF ENERGY



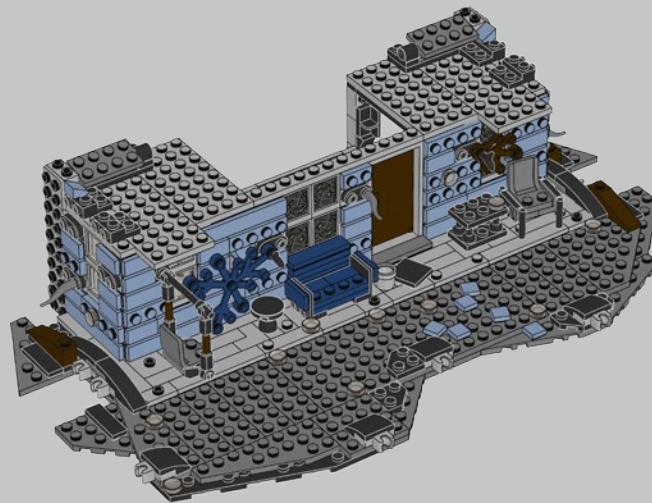
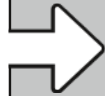
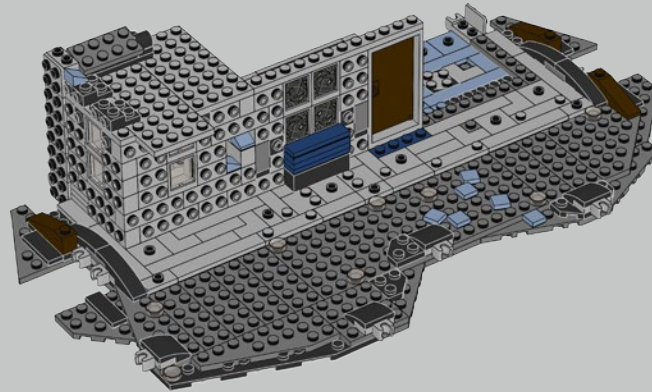
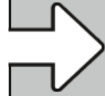
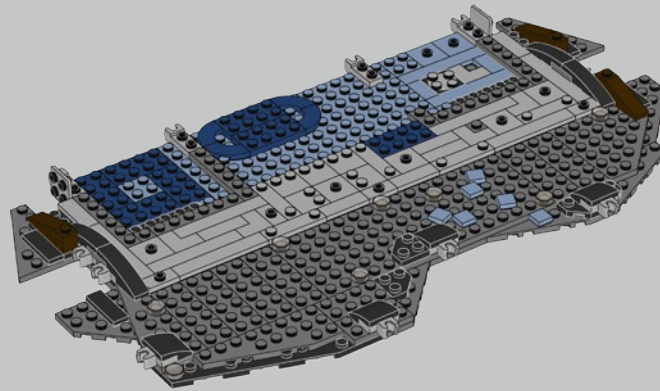
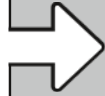

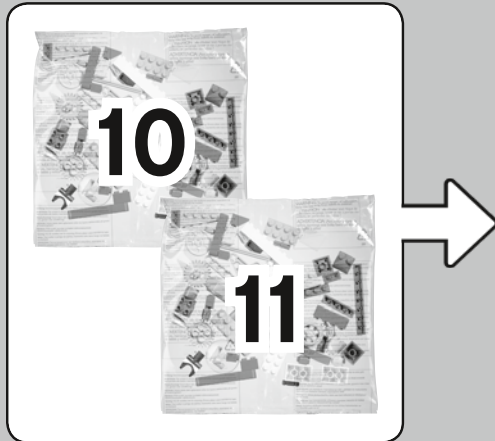
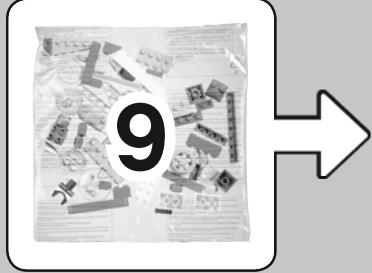

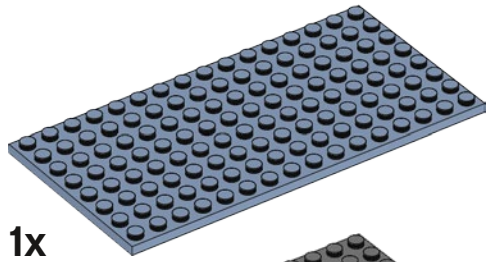

1x

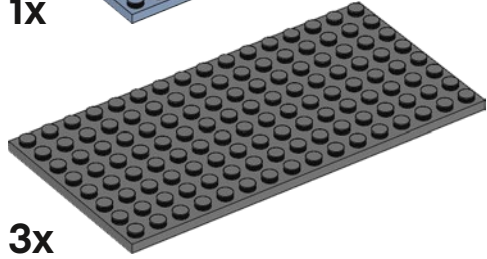

3x

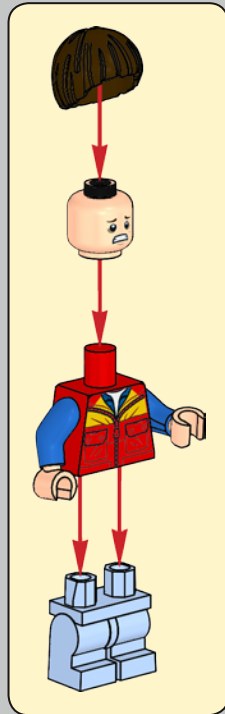
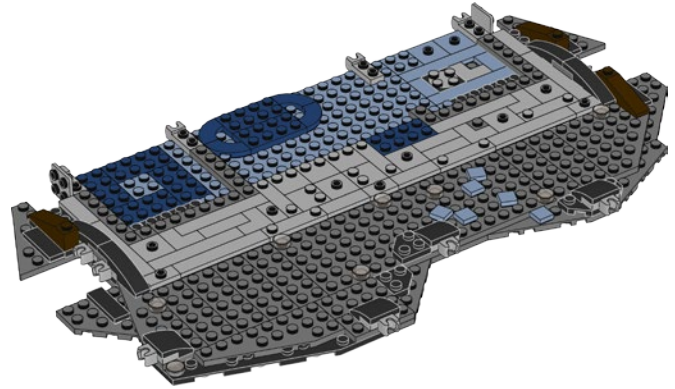
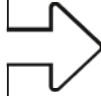

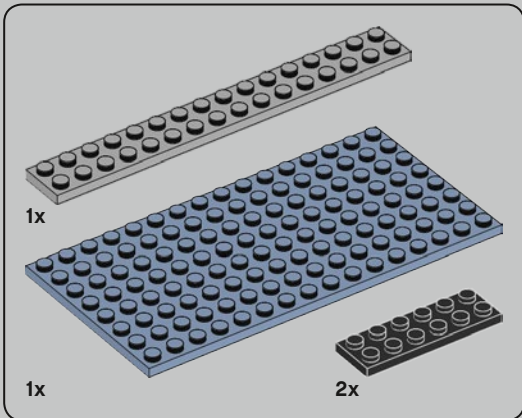
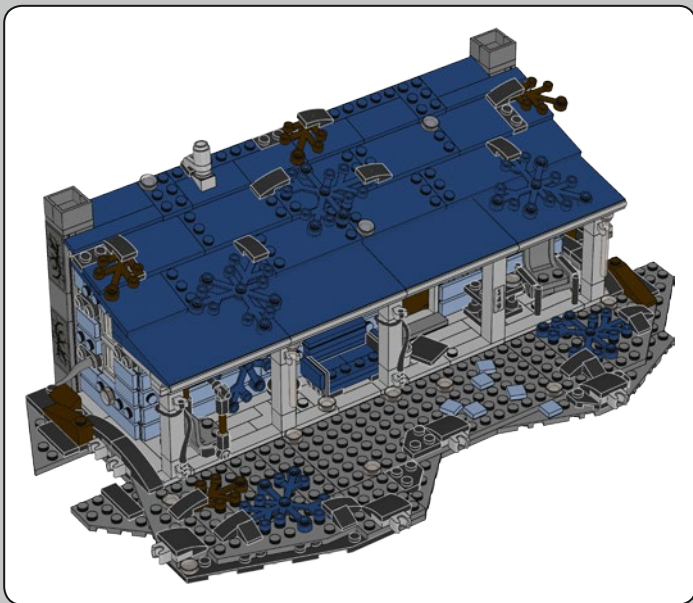

124

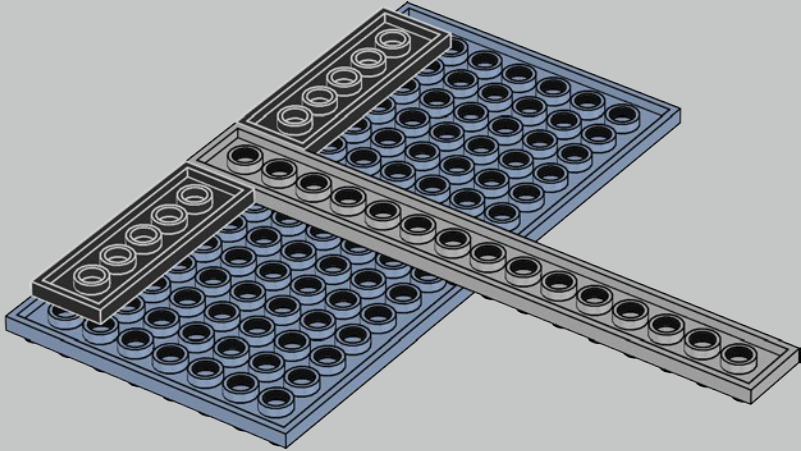

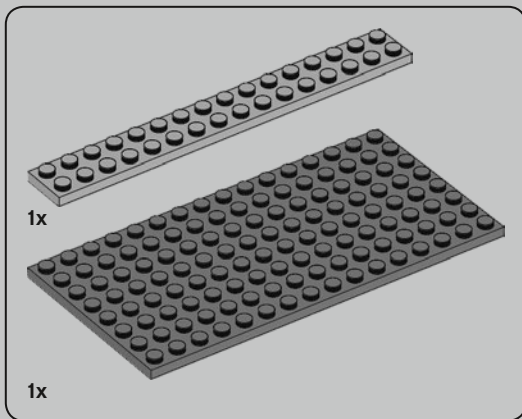

125

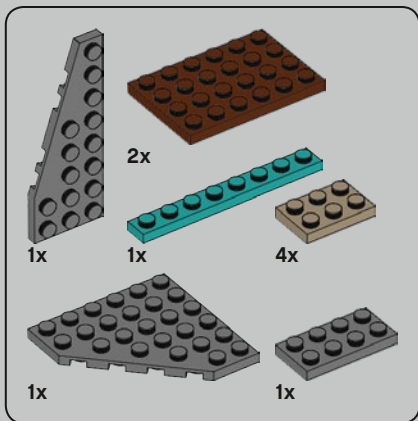
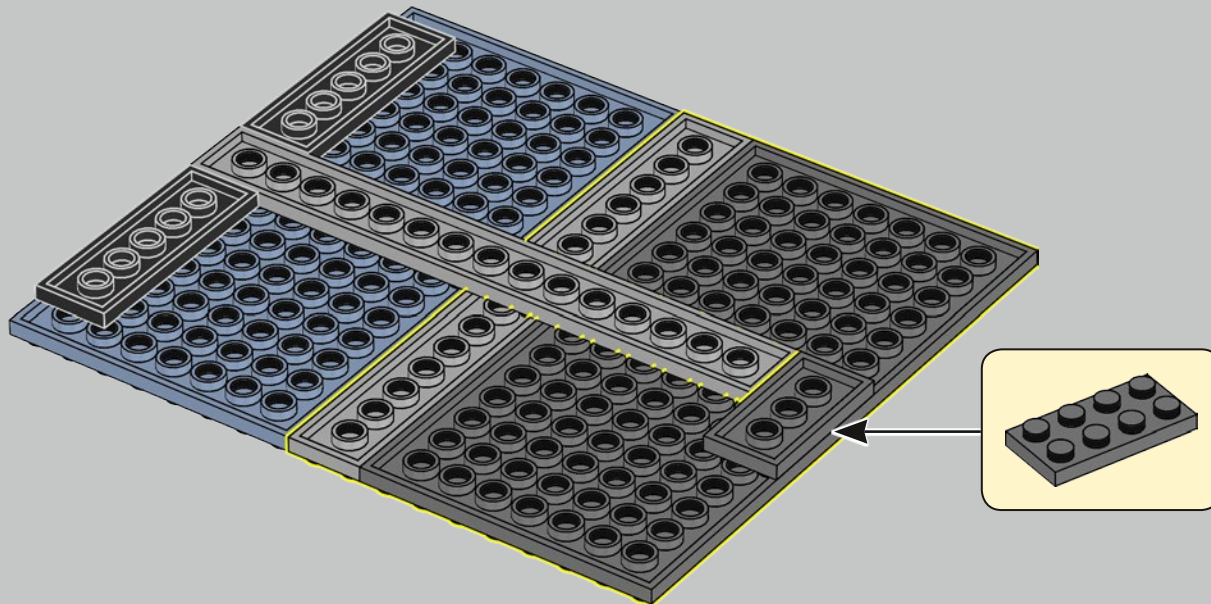

126

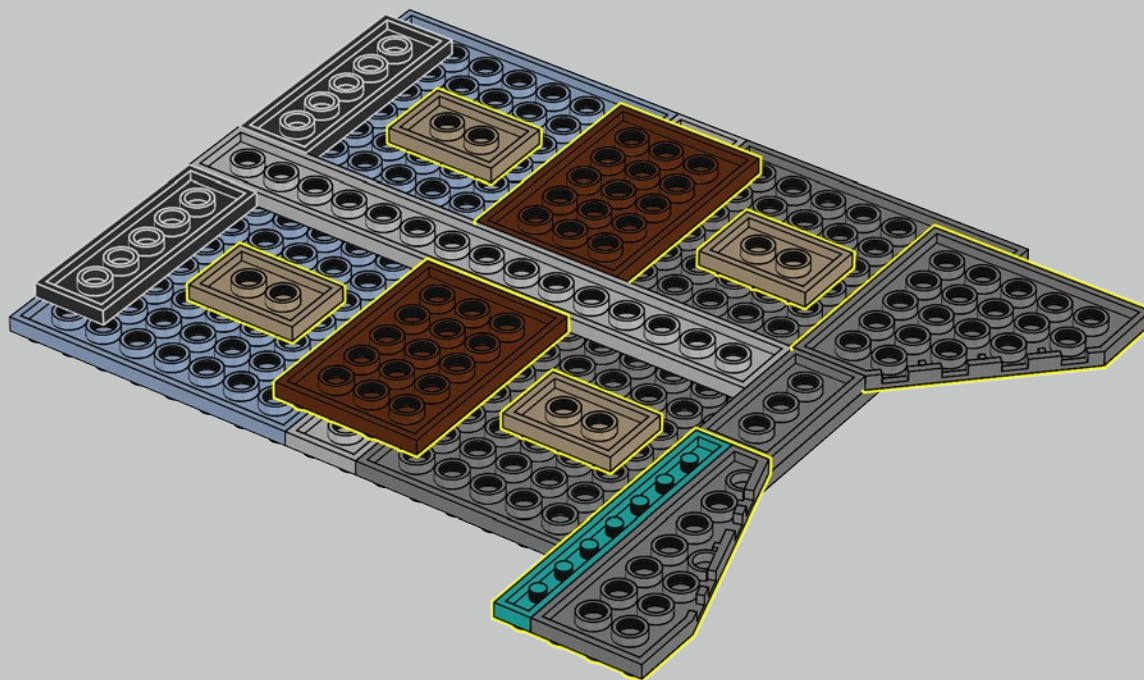

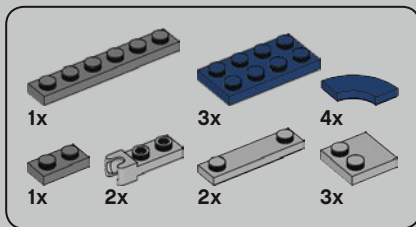

127

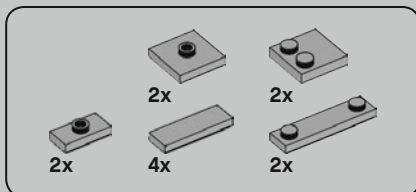
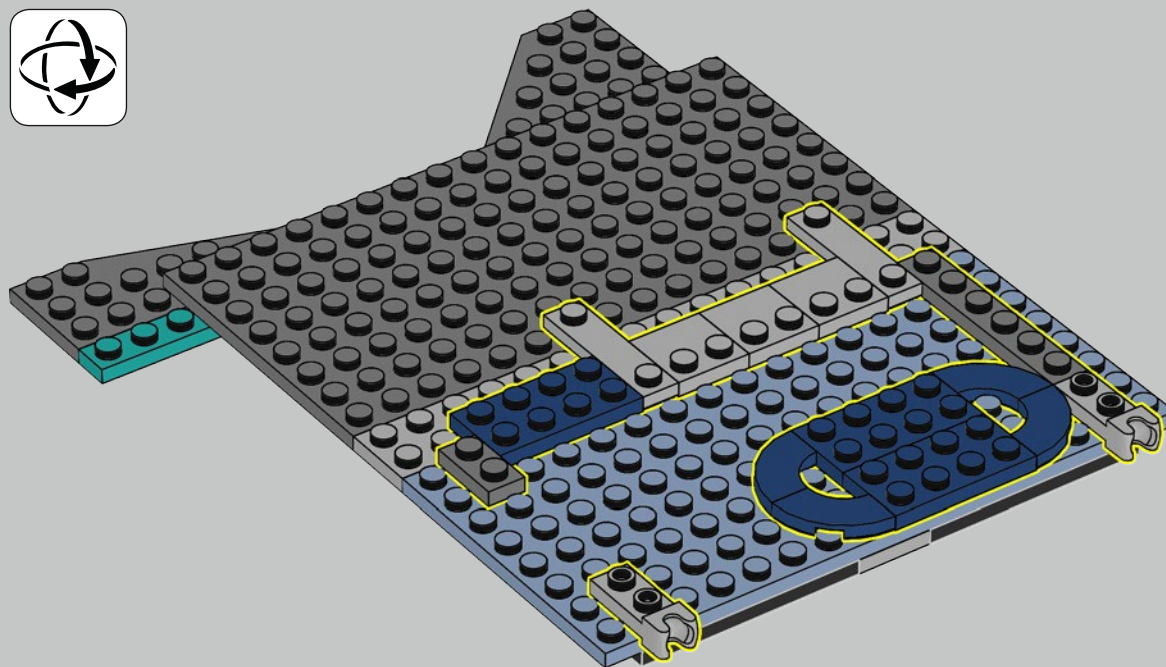

128

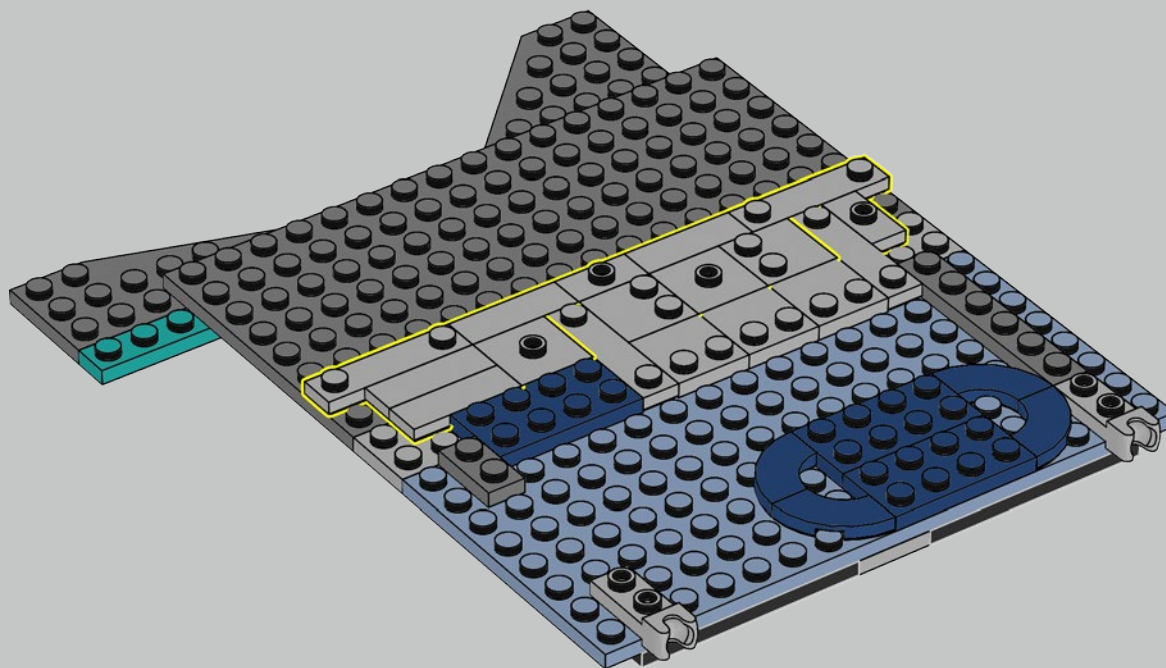

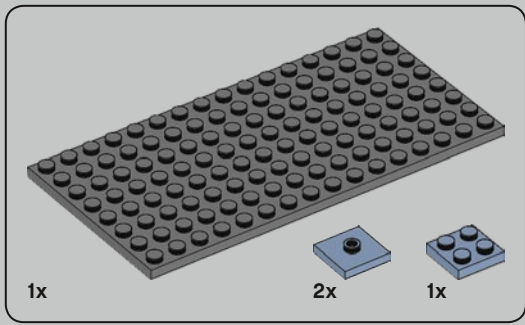

129

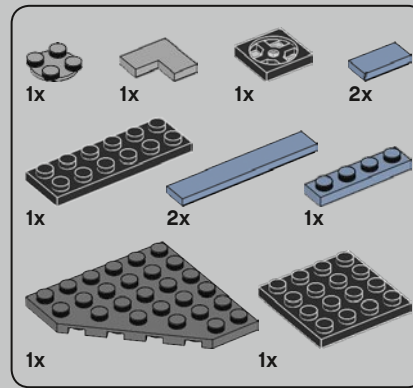
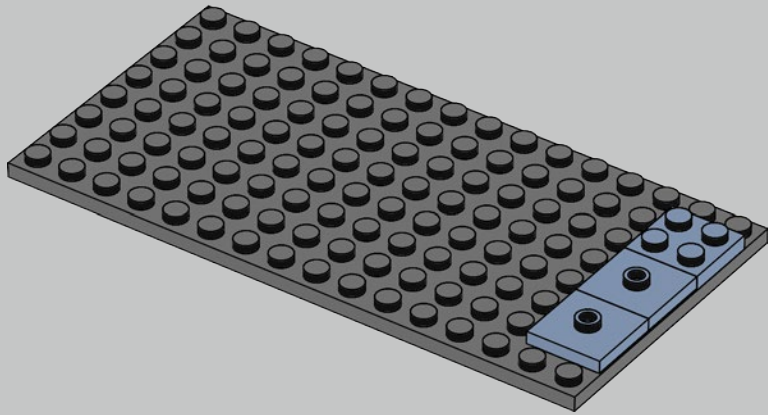

130

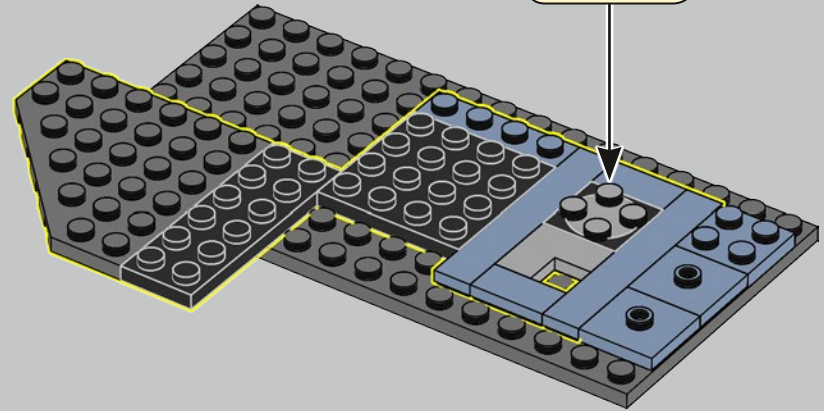
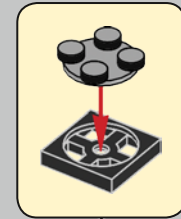

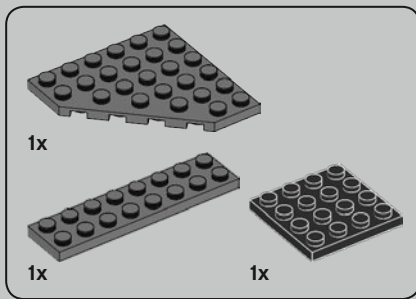

131

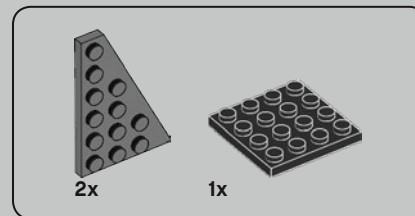
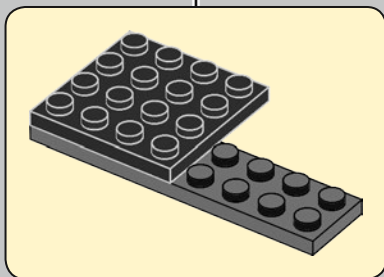
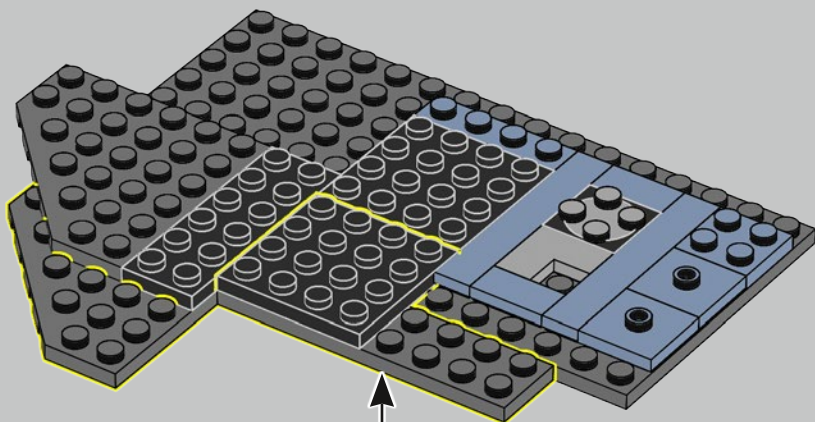

132

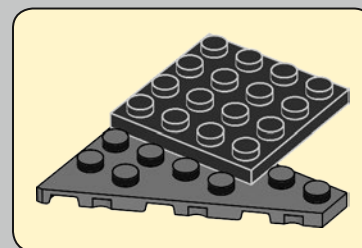
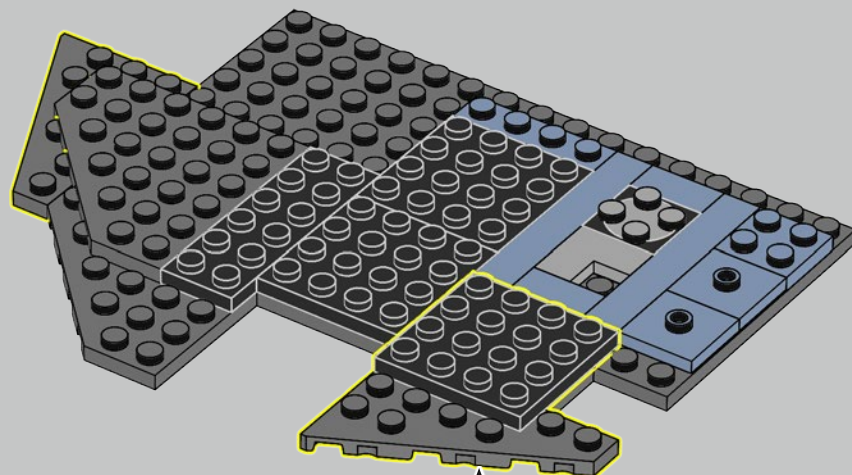

133

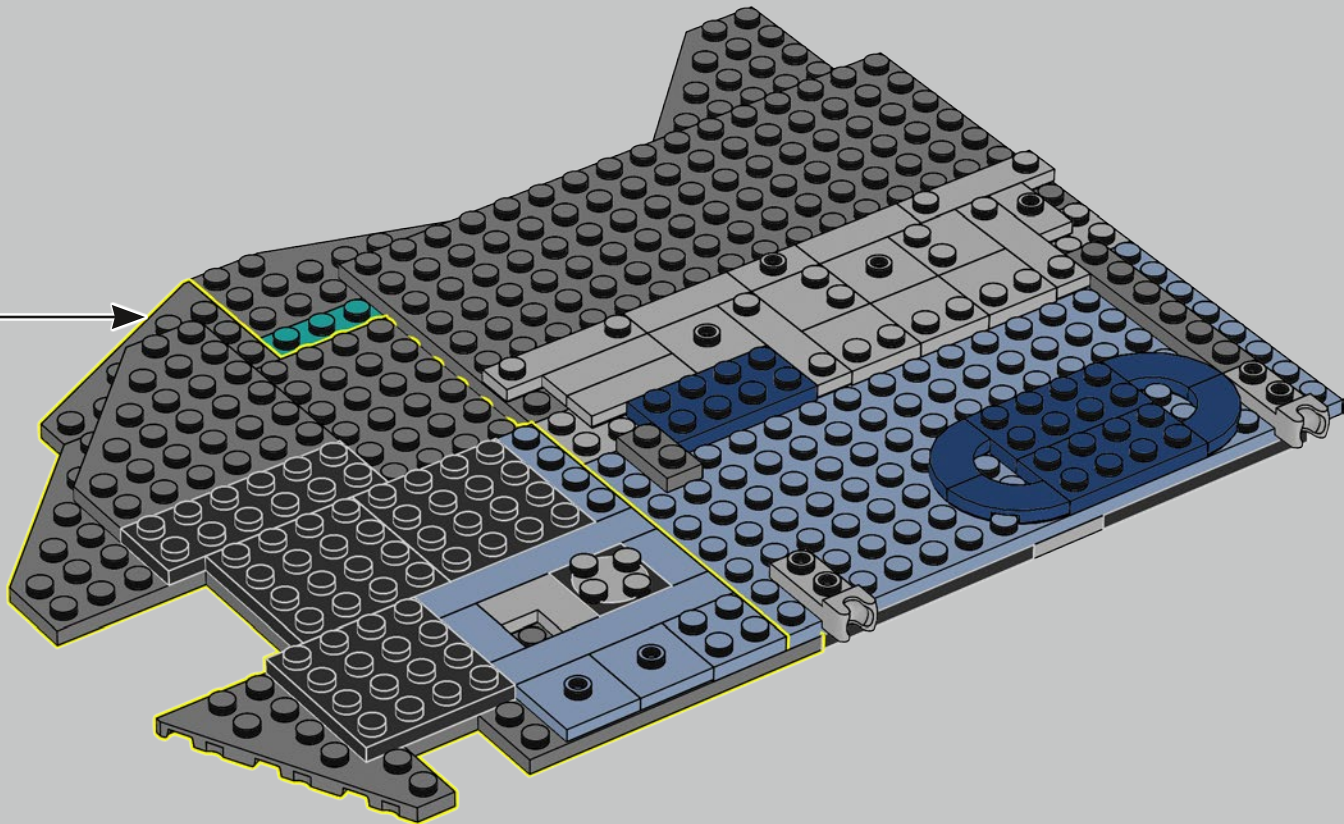

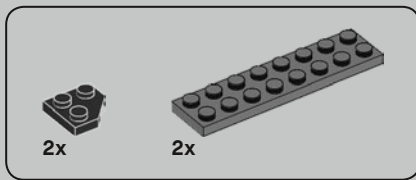

134

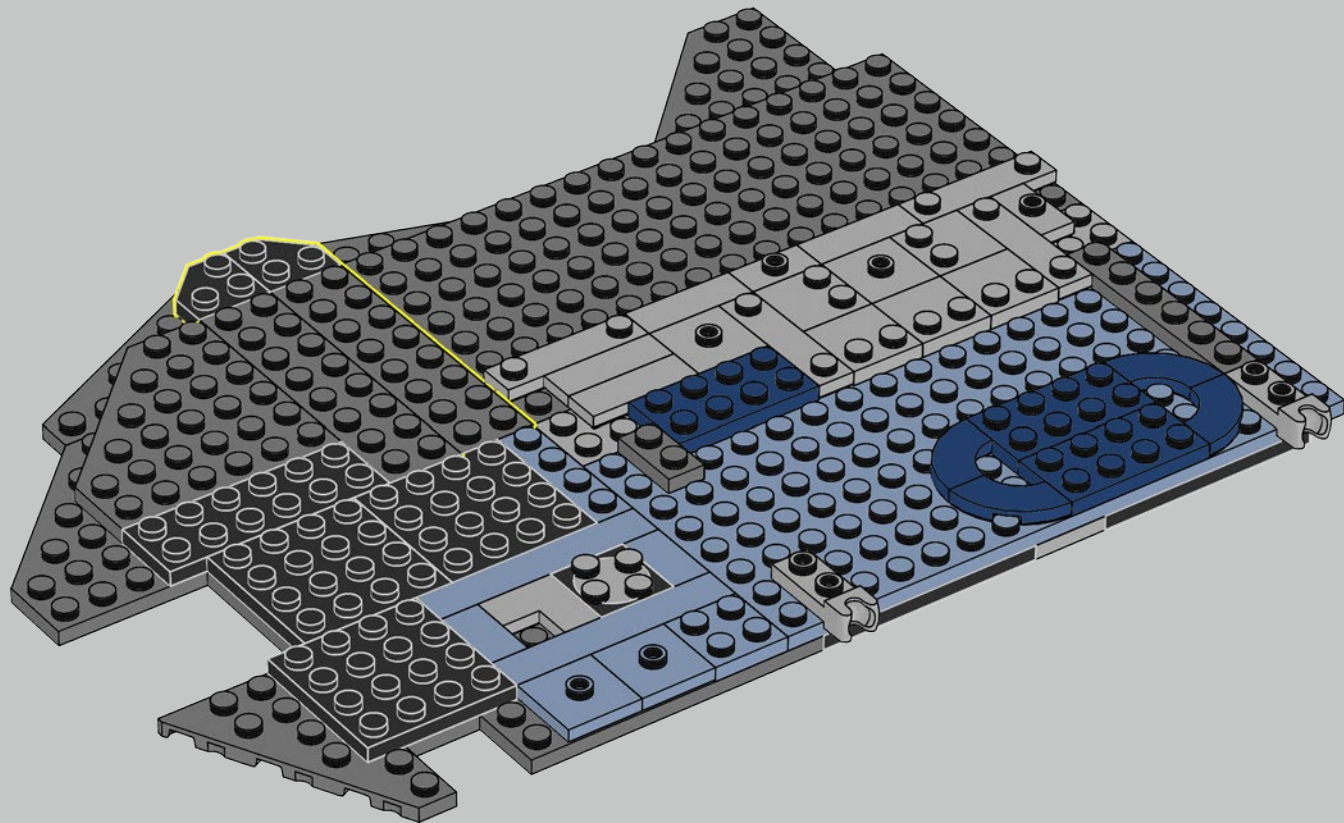

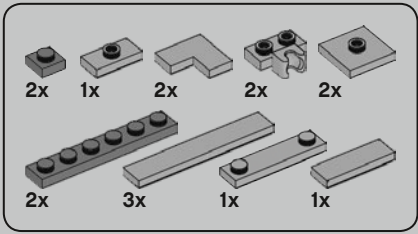

135

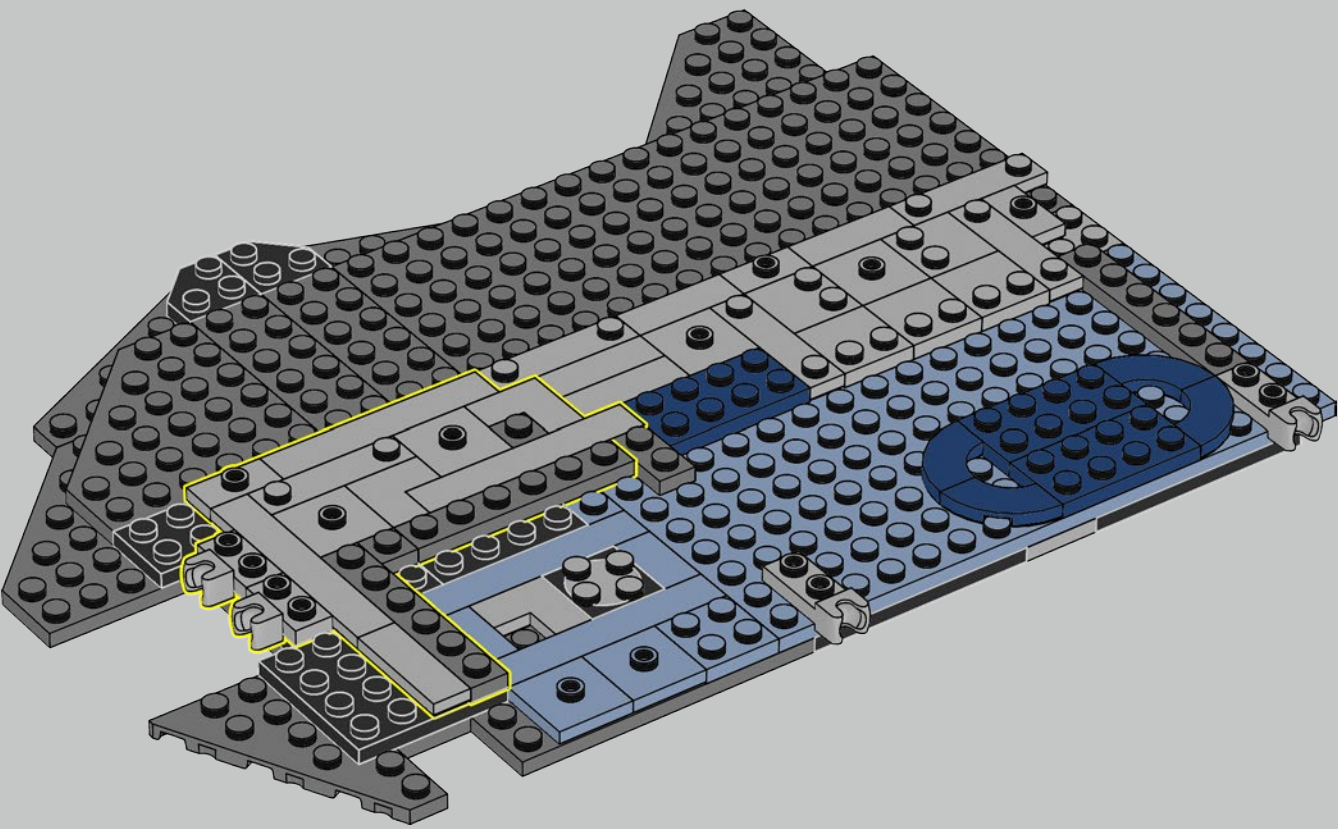

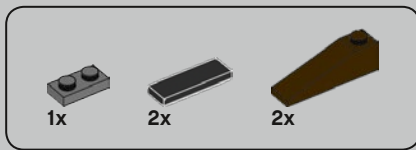

136

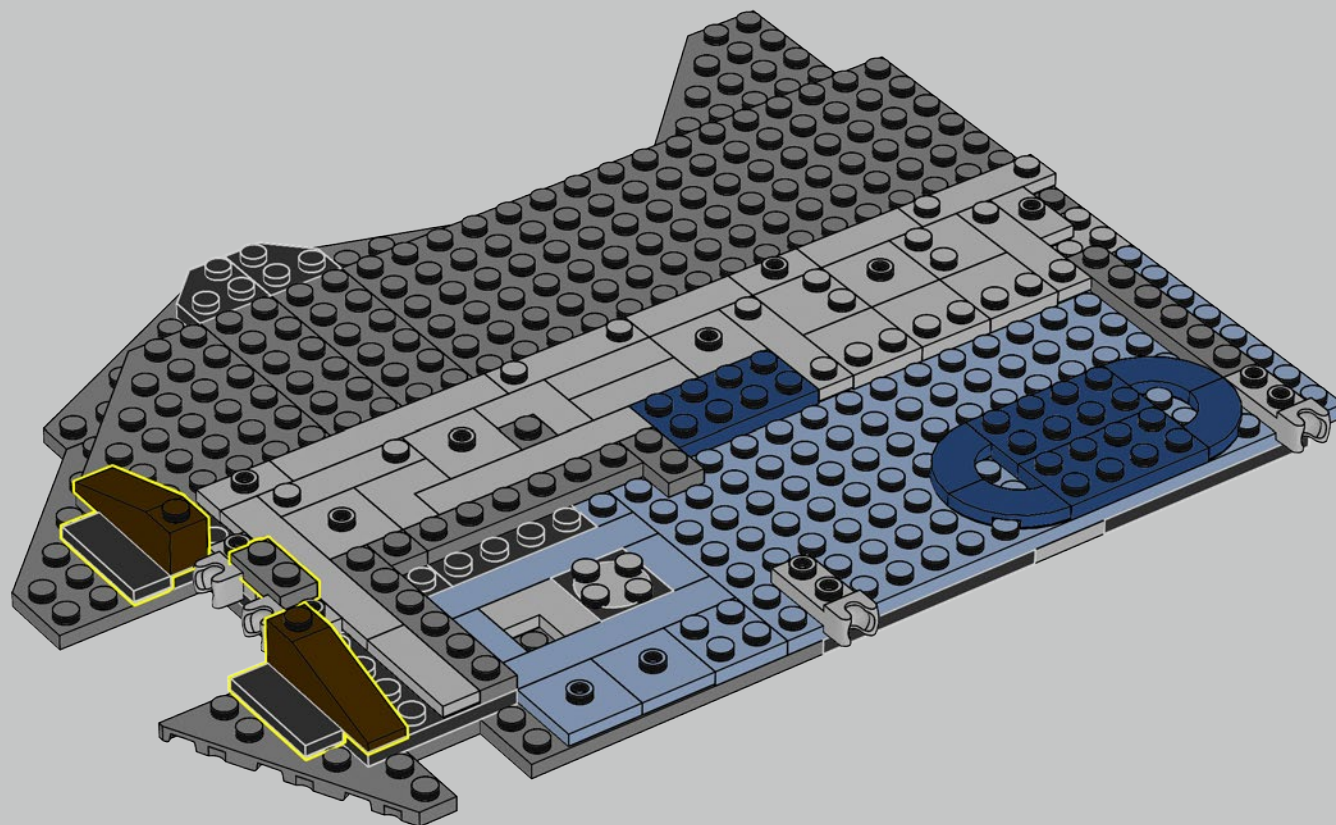

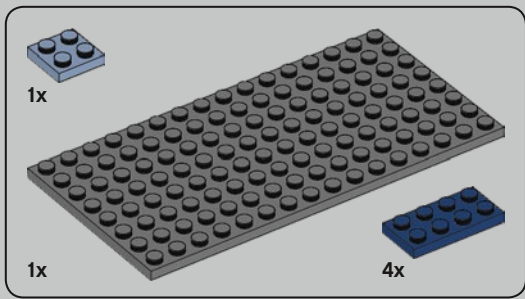

137

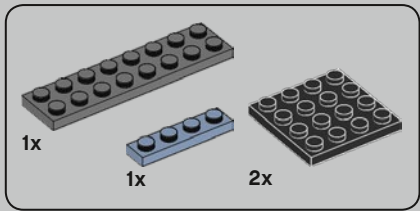
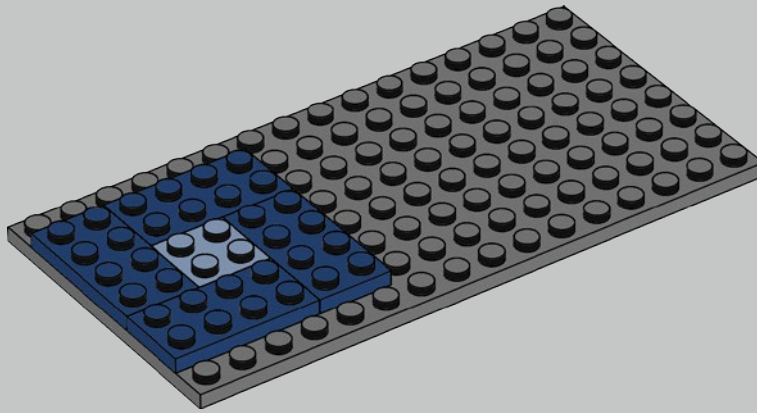

138

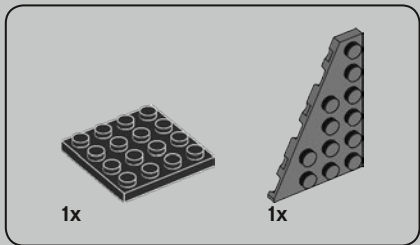
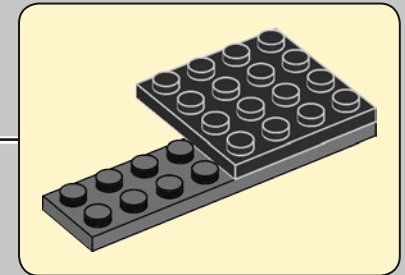
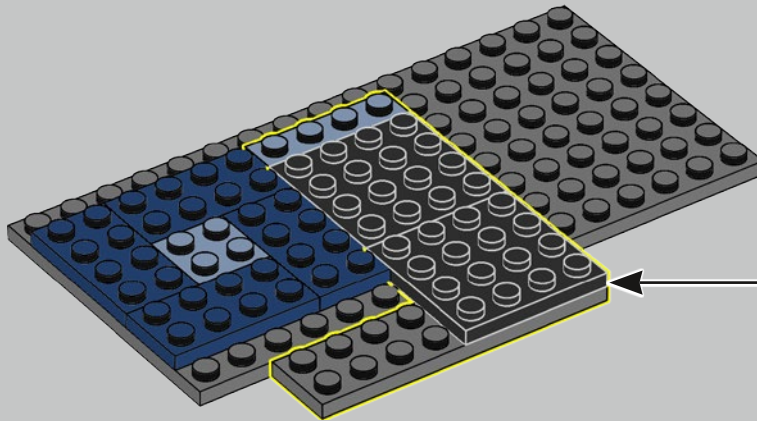

139

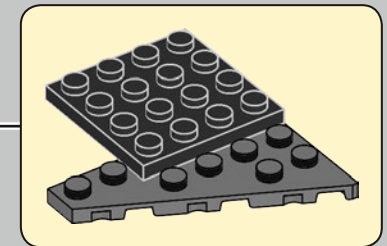
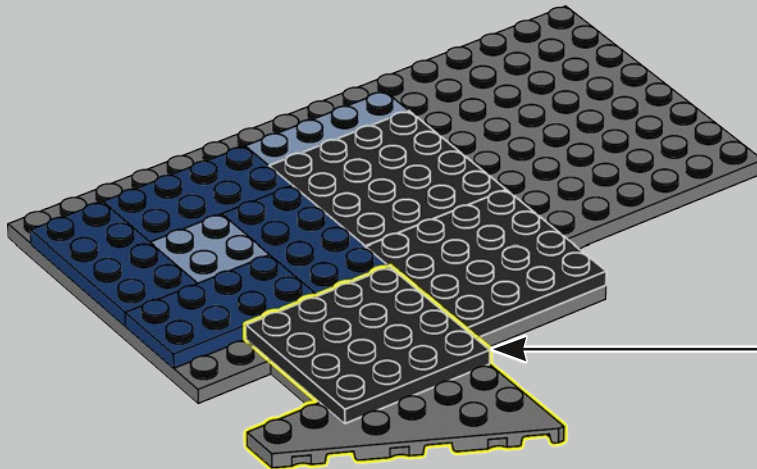

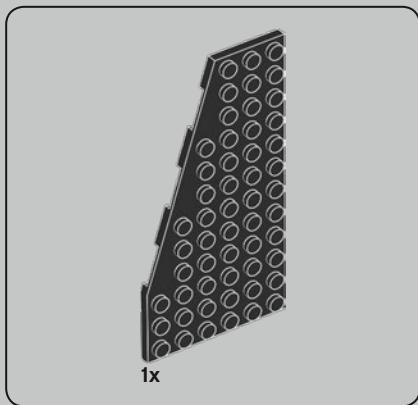

140

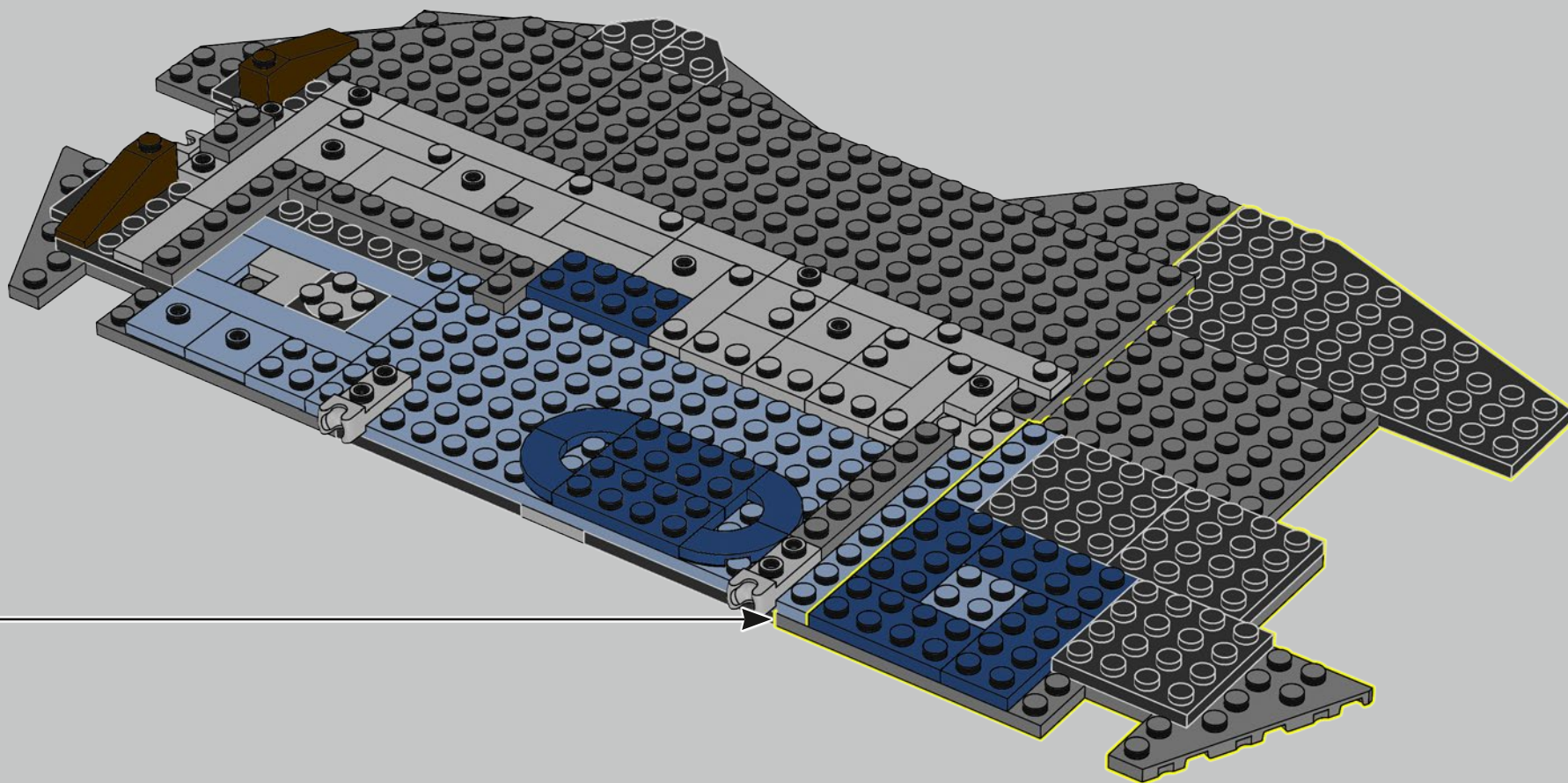

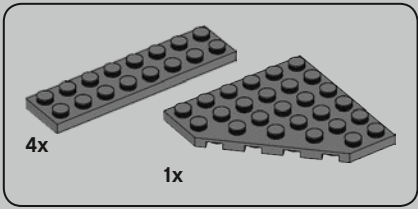

141

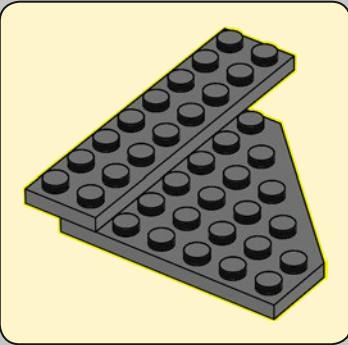
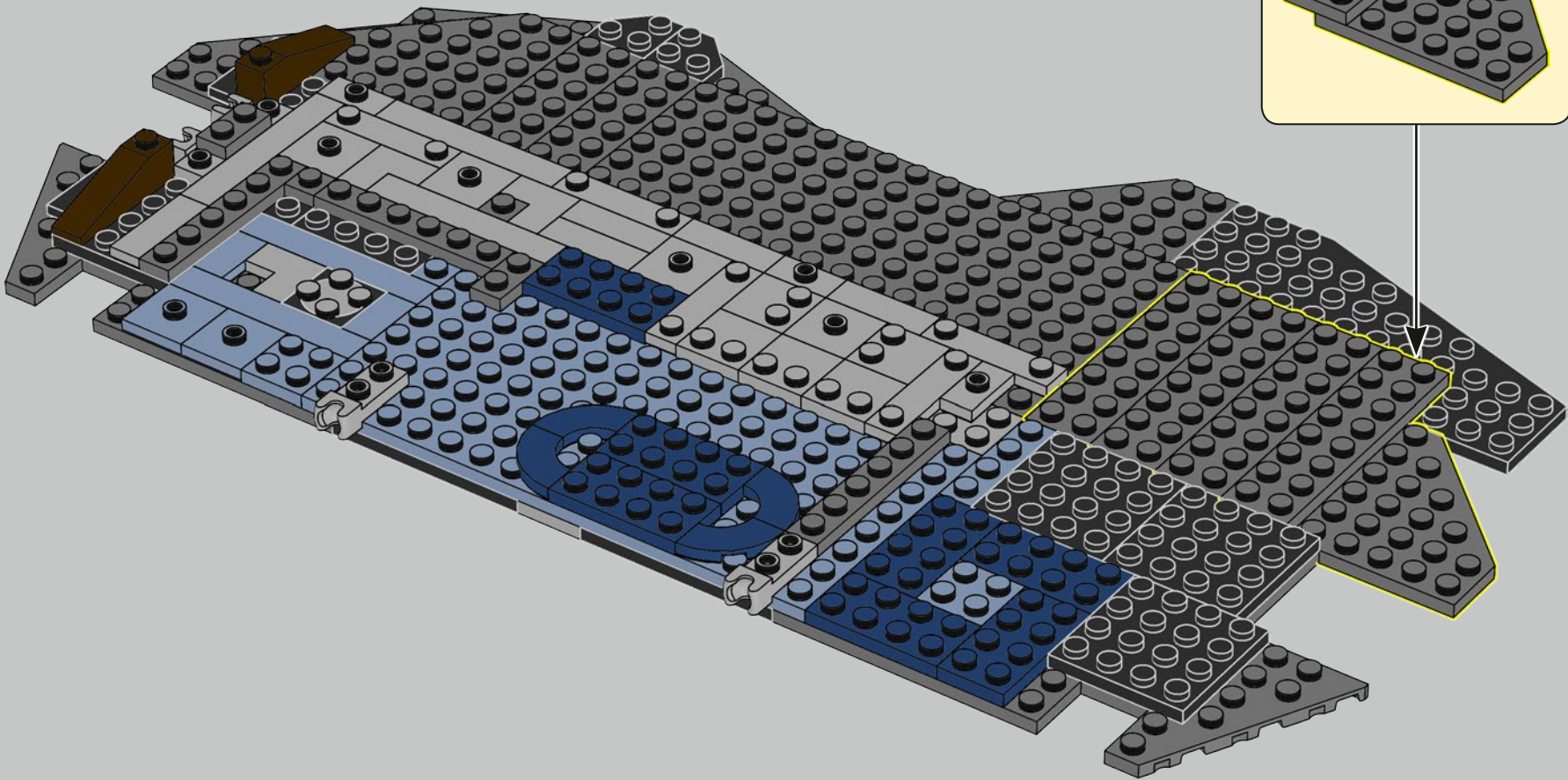

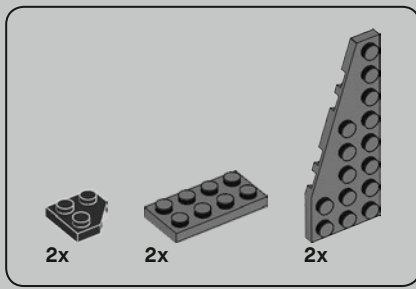

142

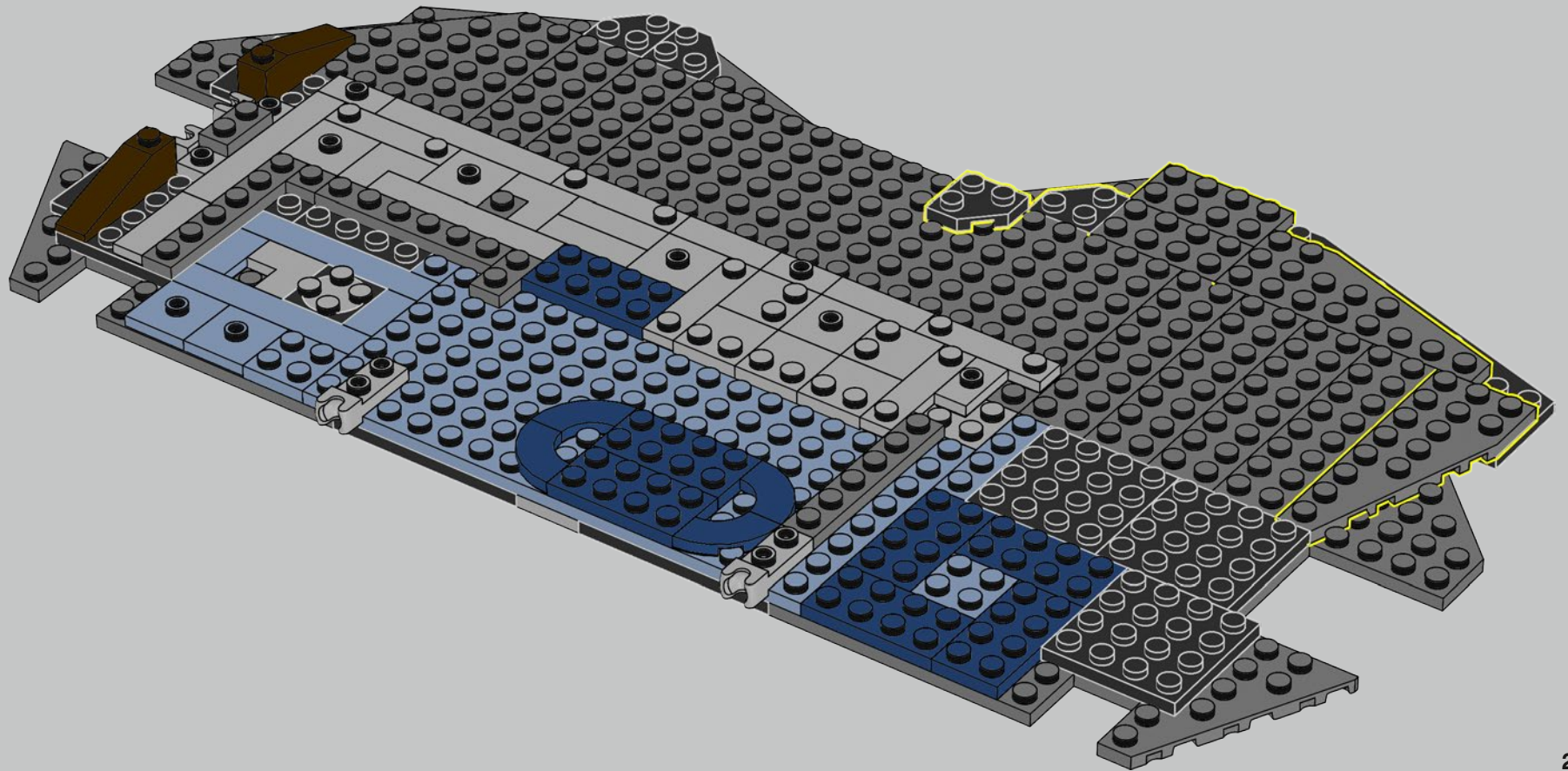

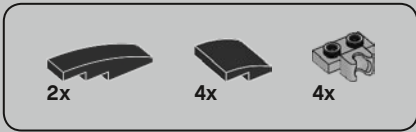

143

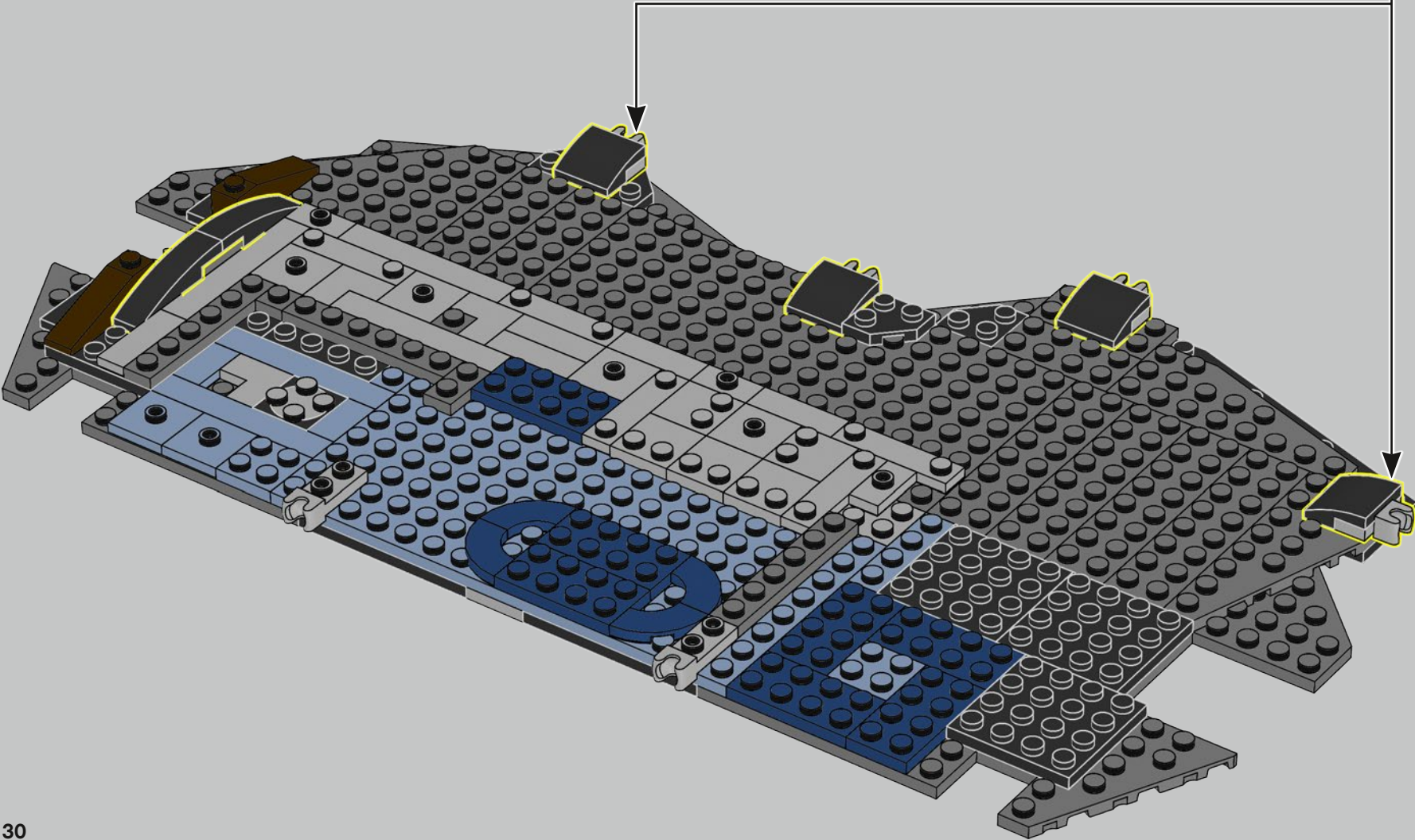
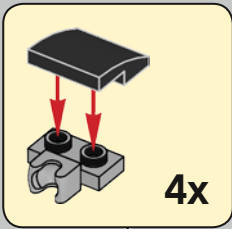

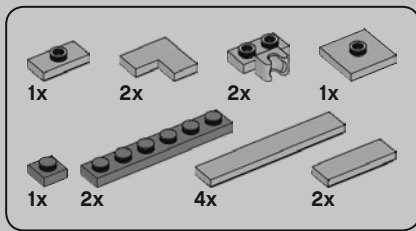

144

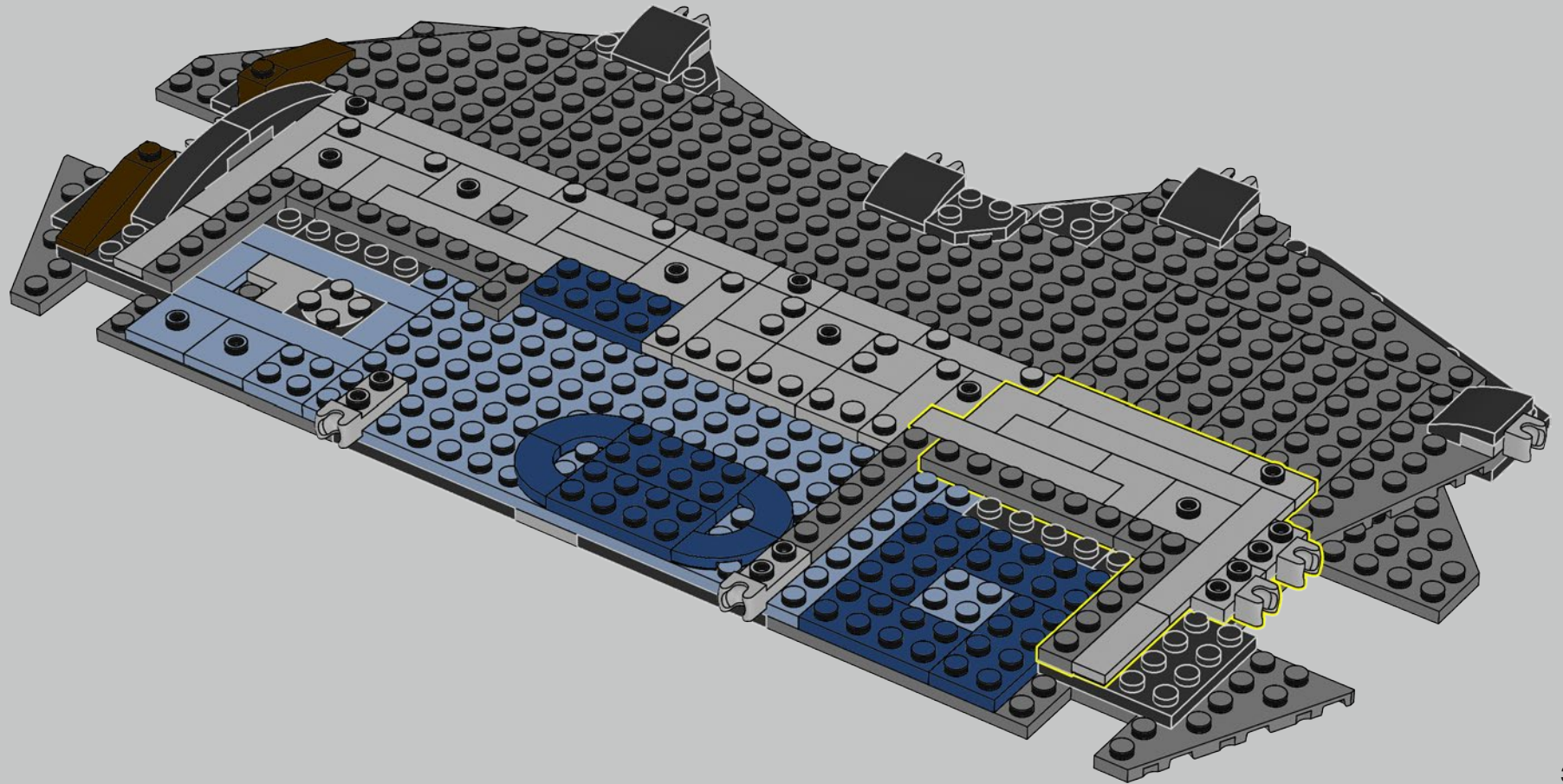

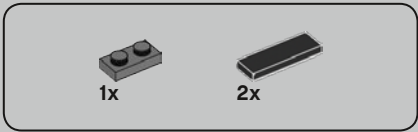

145

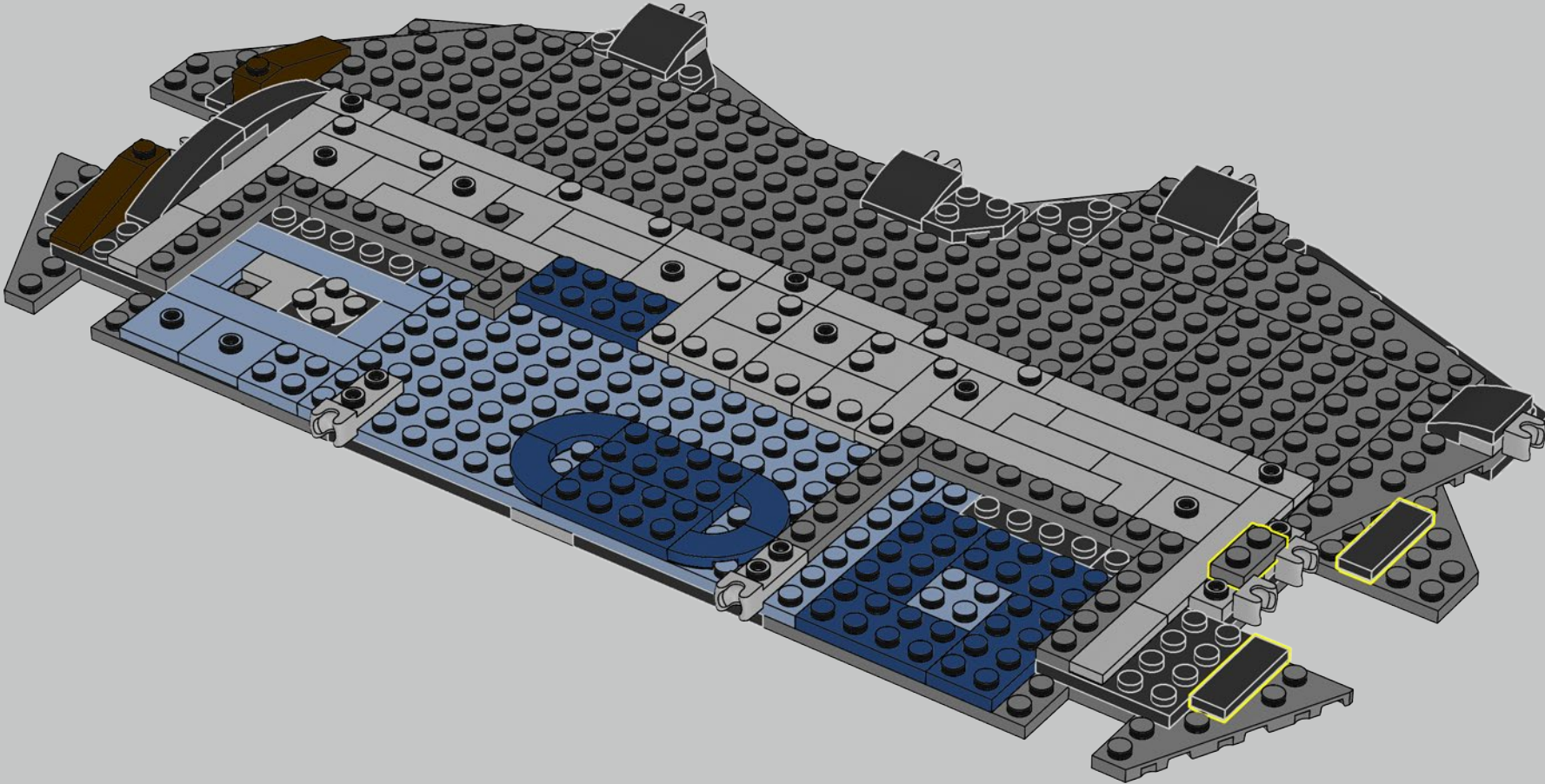

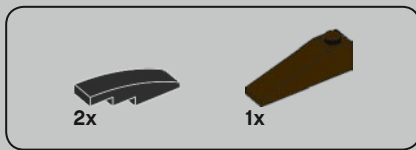

146

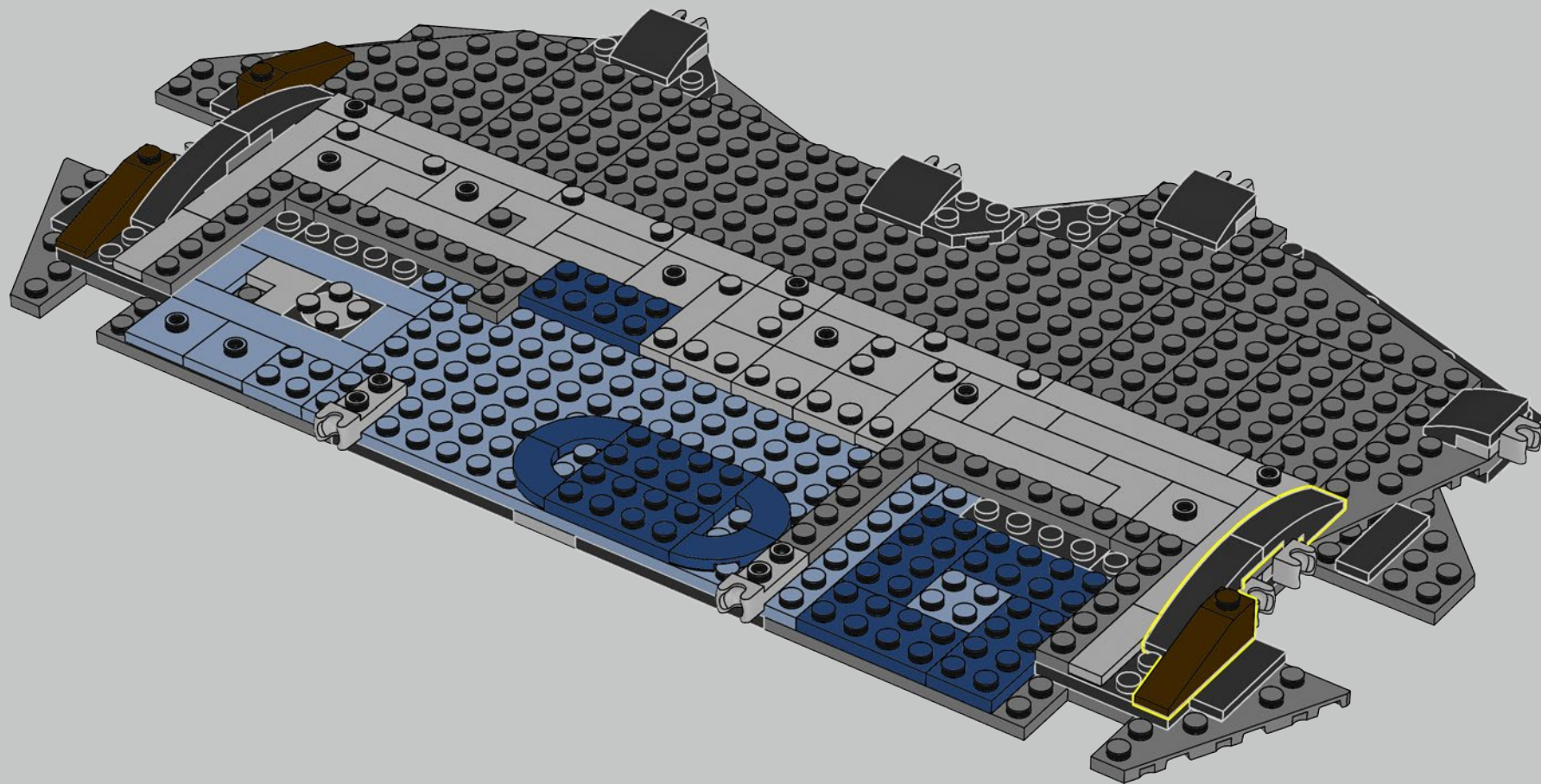

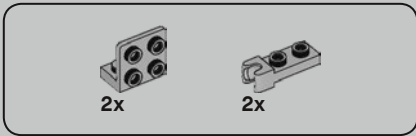

147

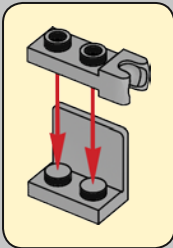
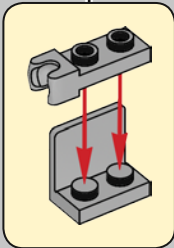
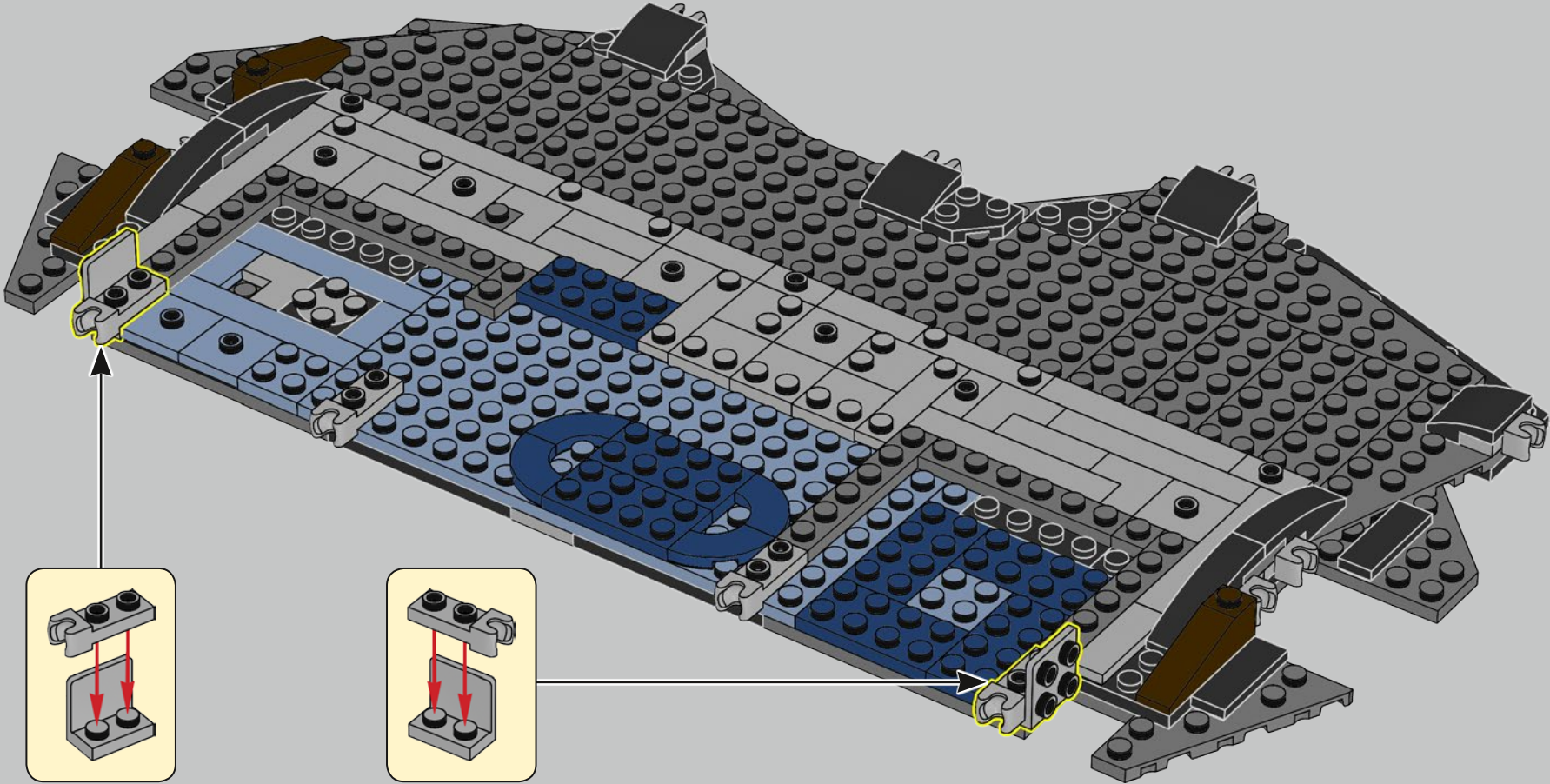

8x 6x

148

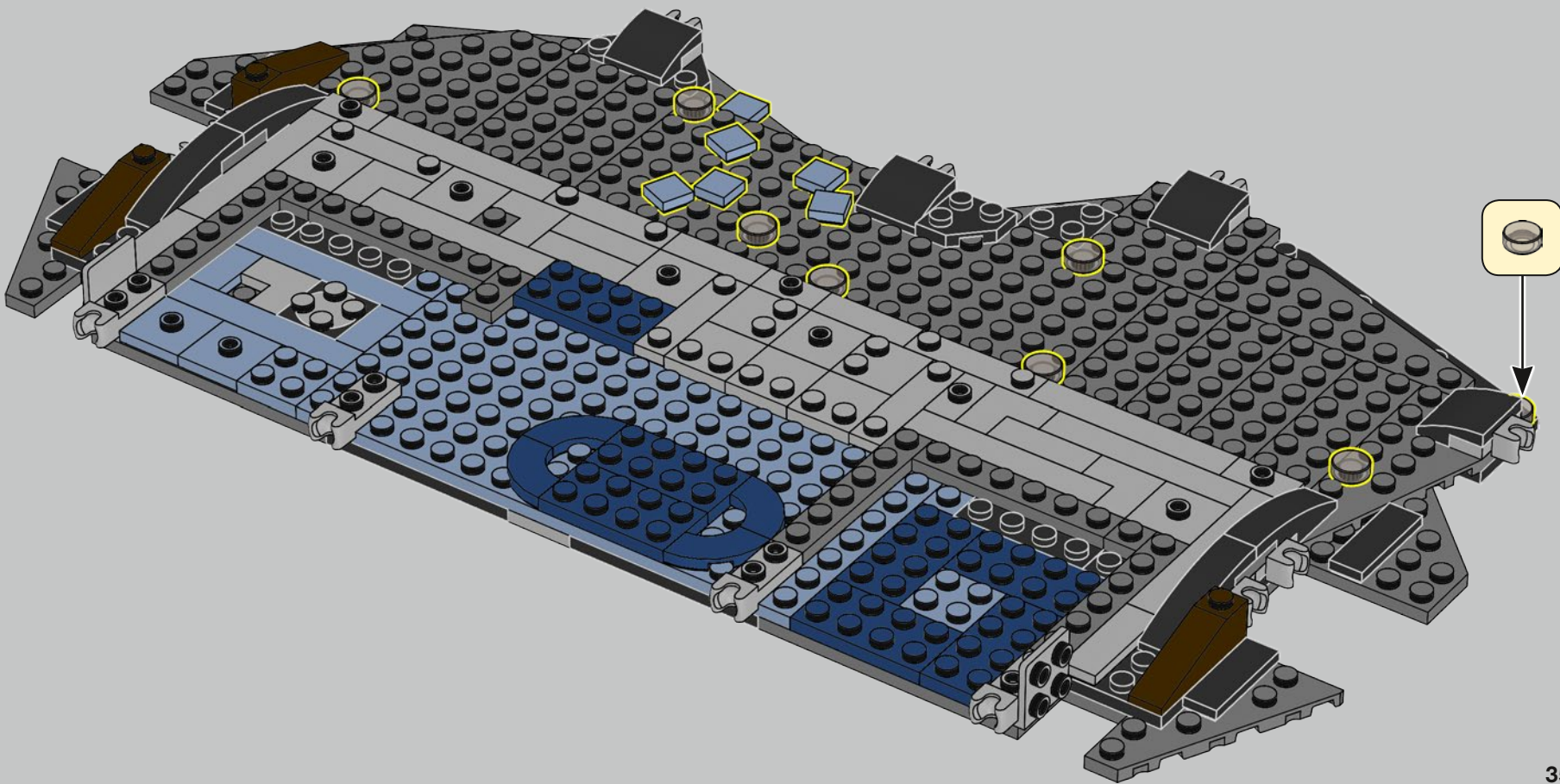

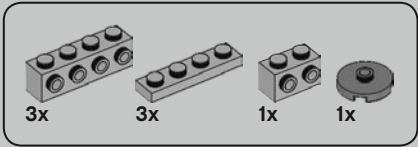
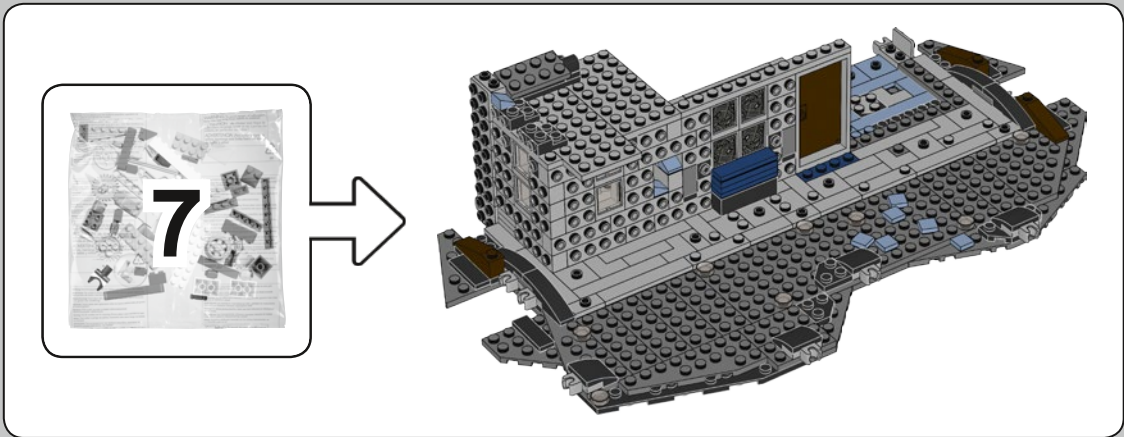

149

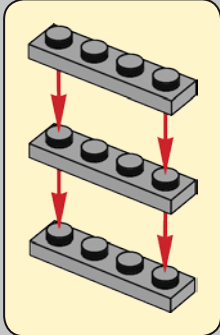
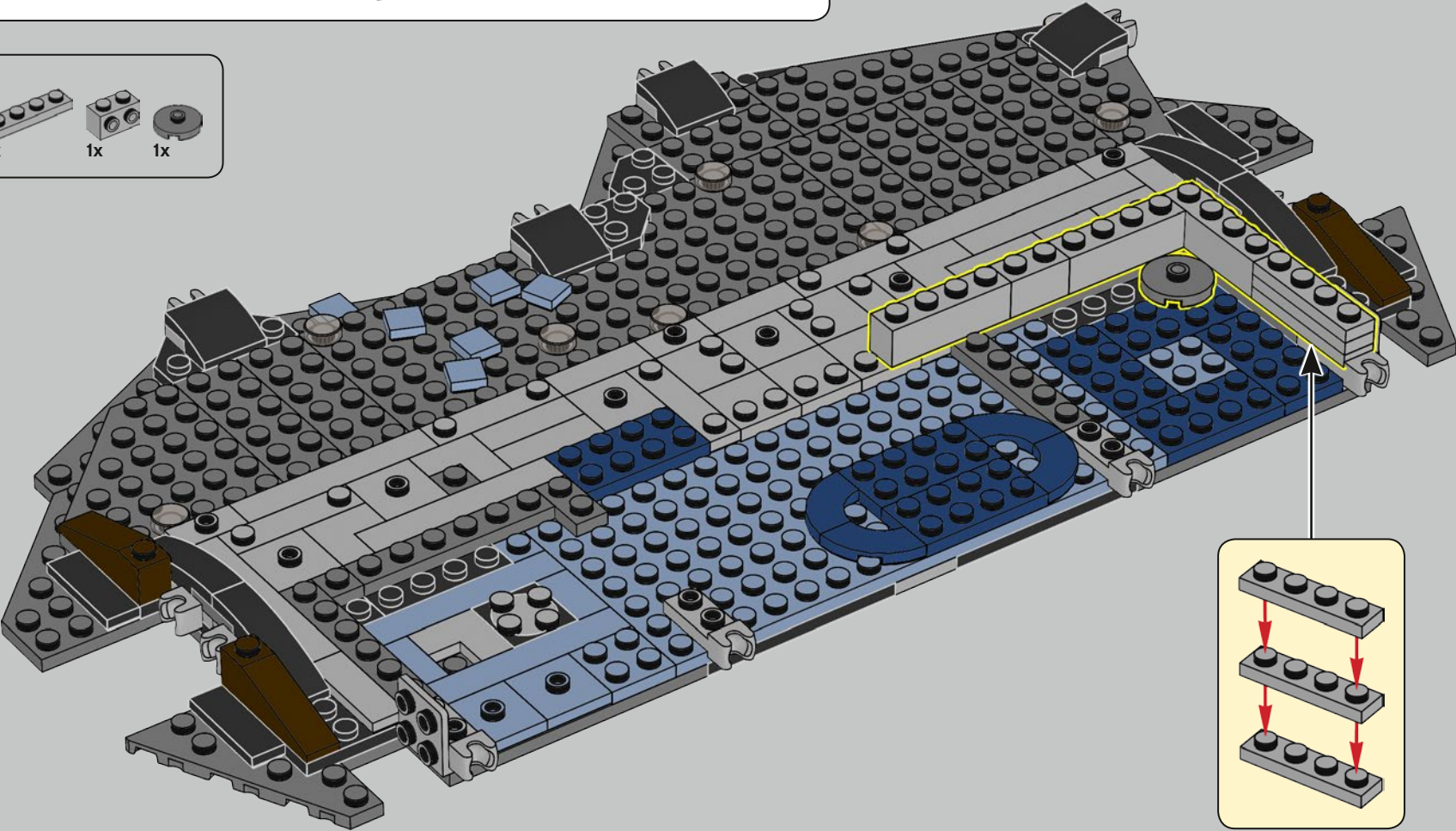

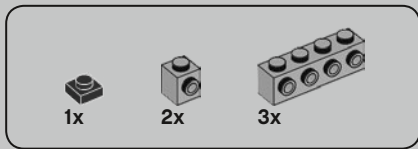

150

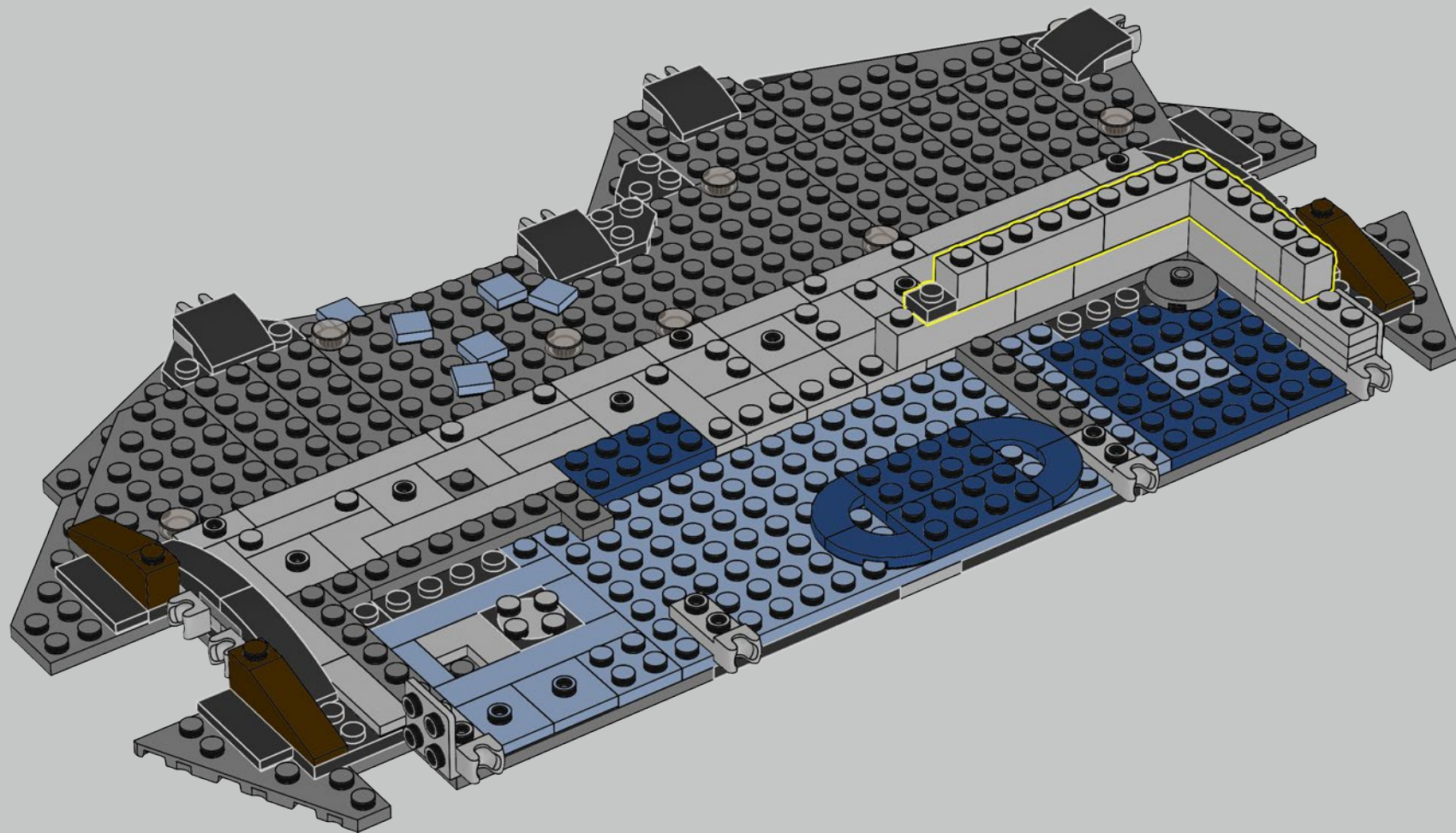



151

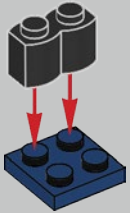

152

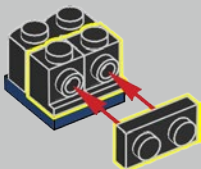

153

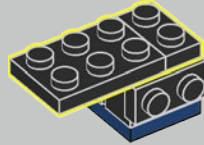

154

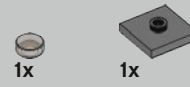
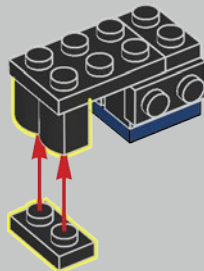

155

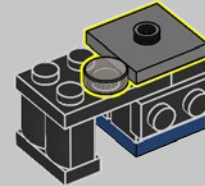

156

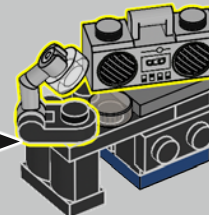
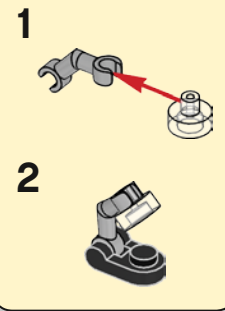

157

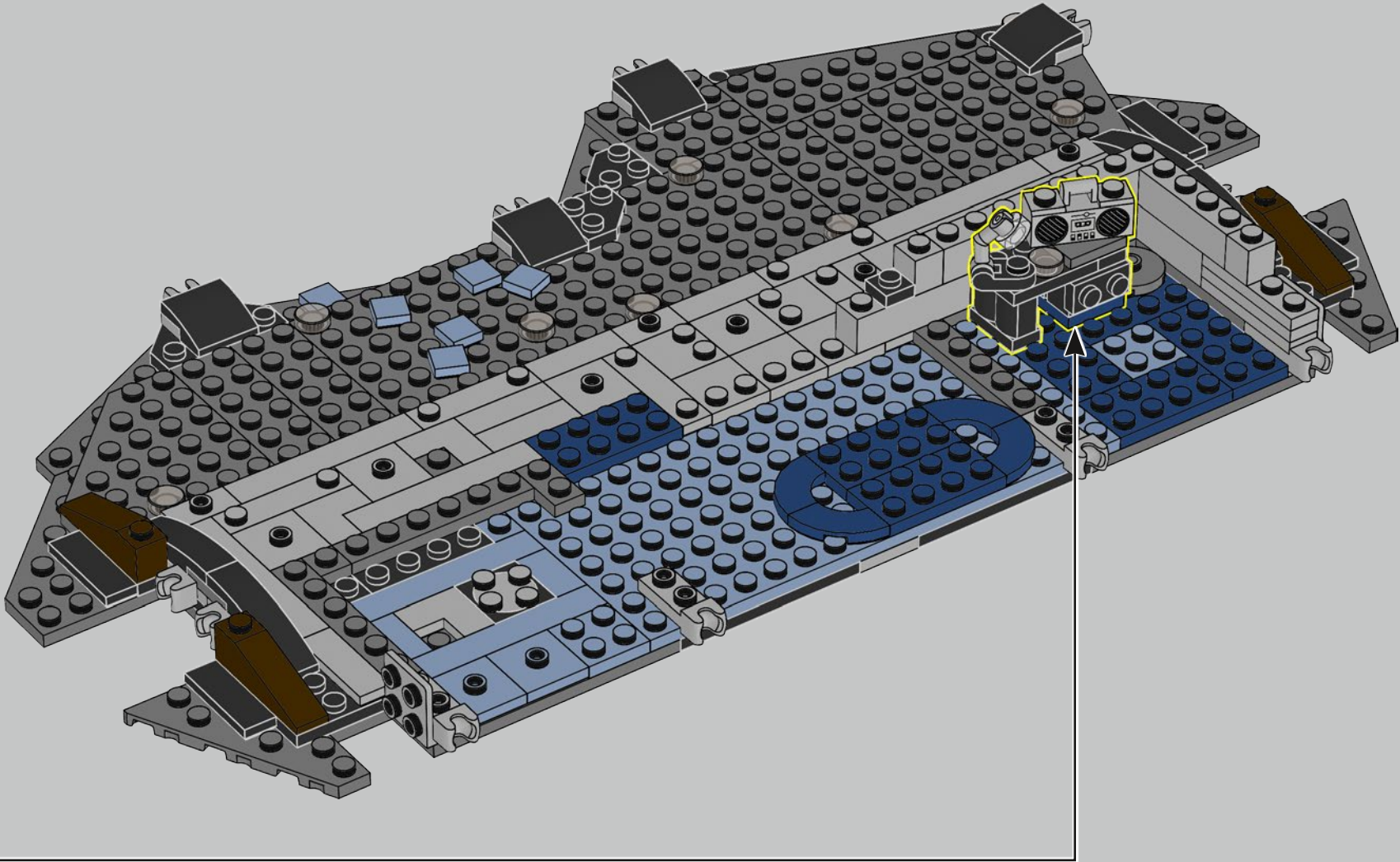

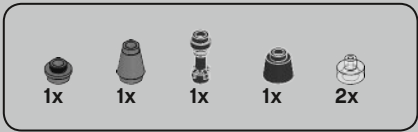

158

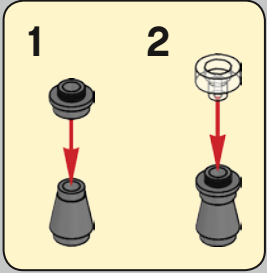
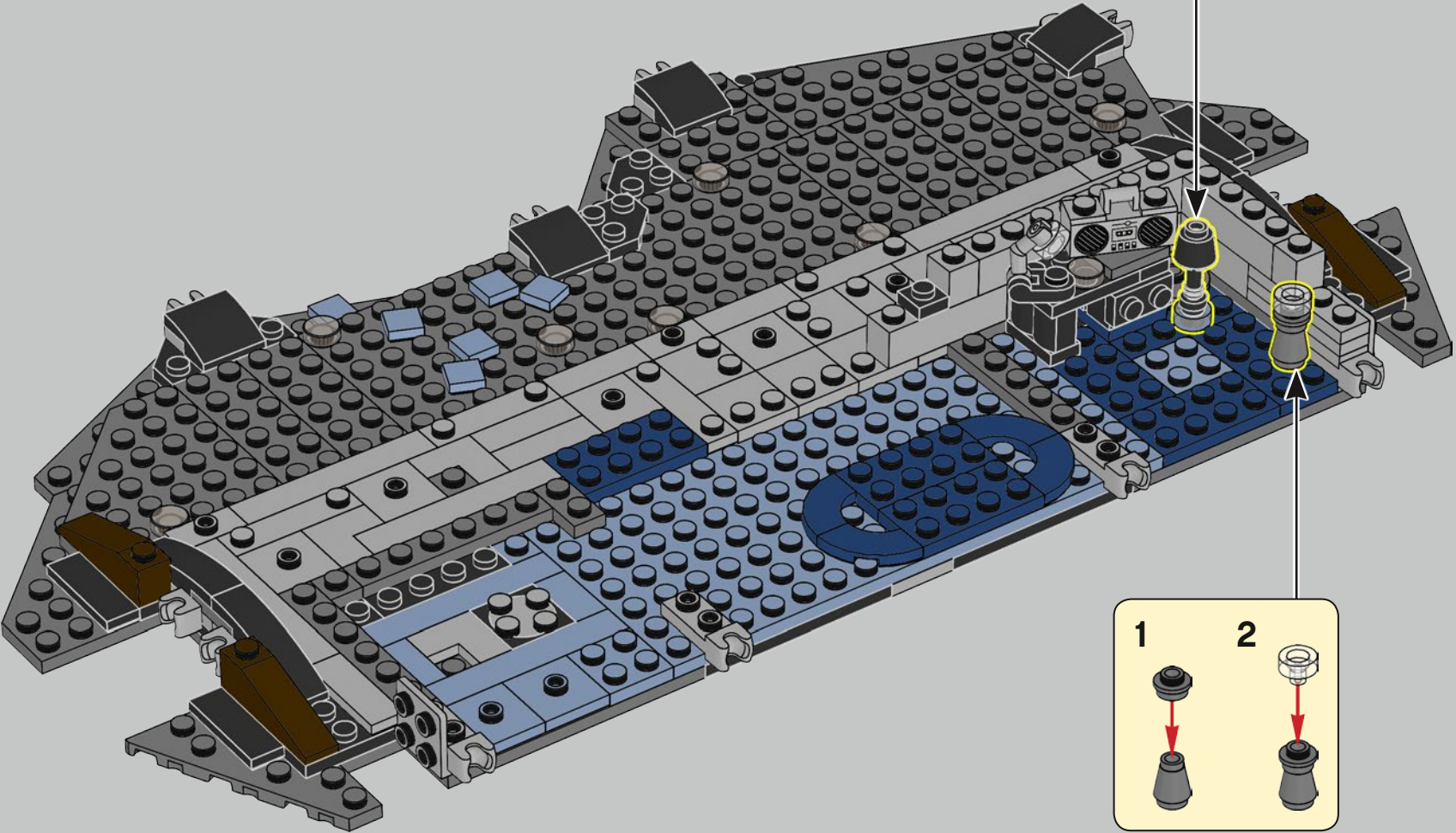
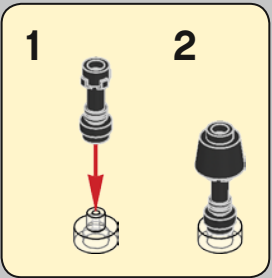

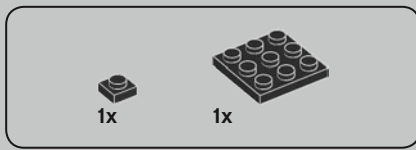

159

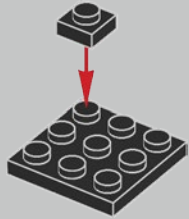

160

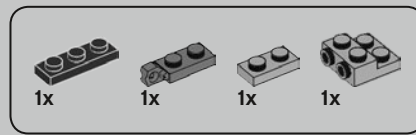
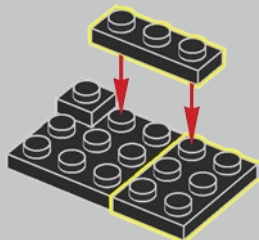

161

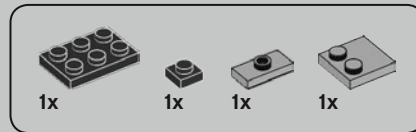
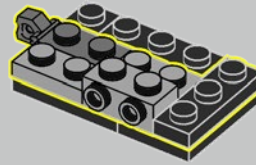

162

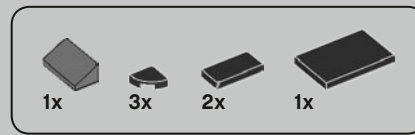
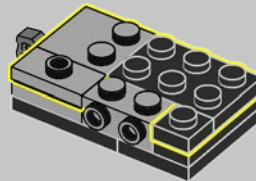

163

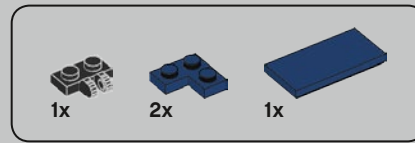
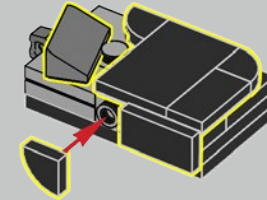

164

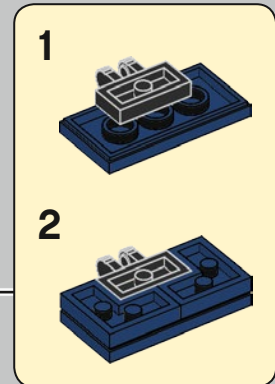
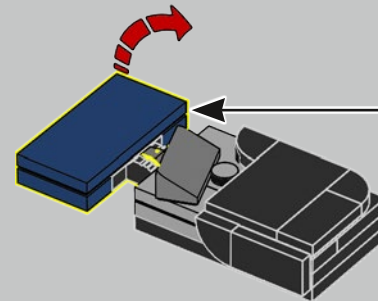

165

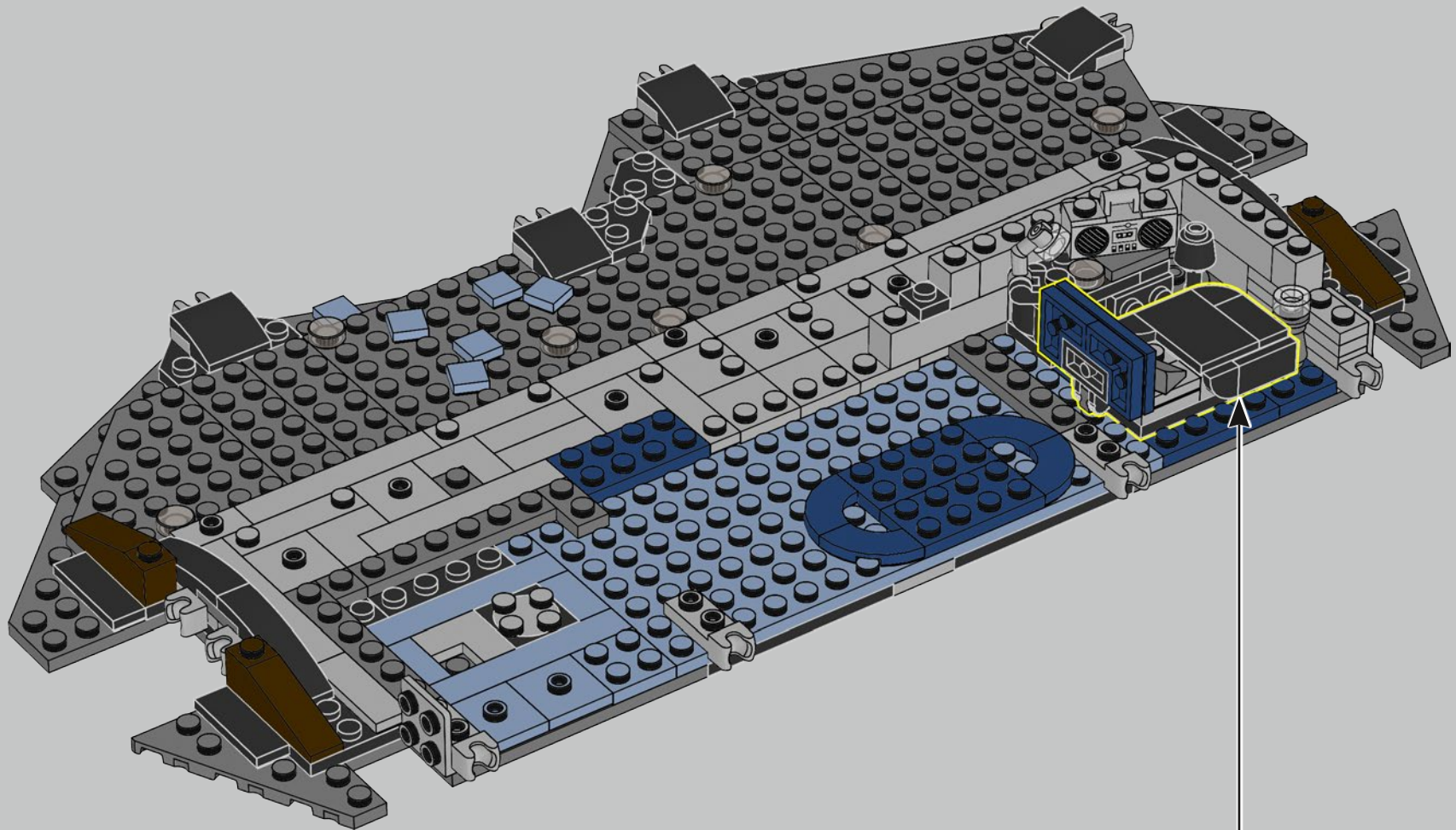

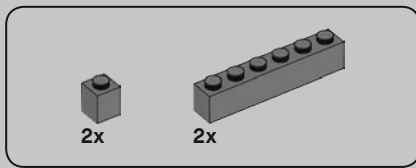

166

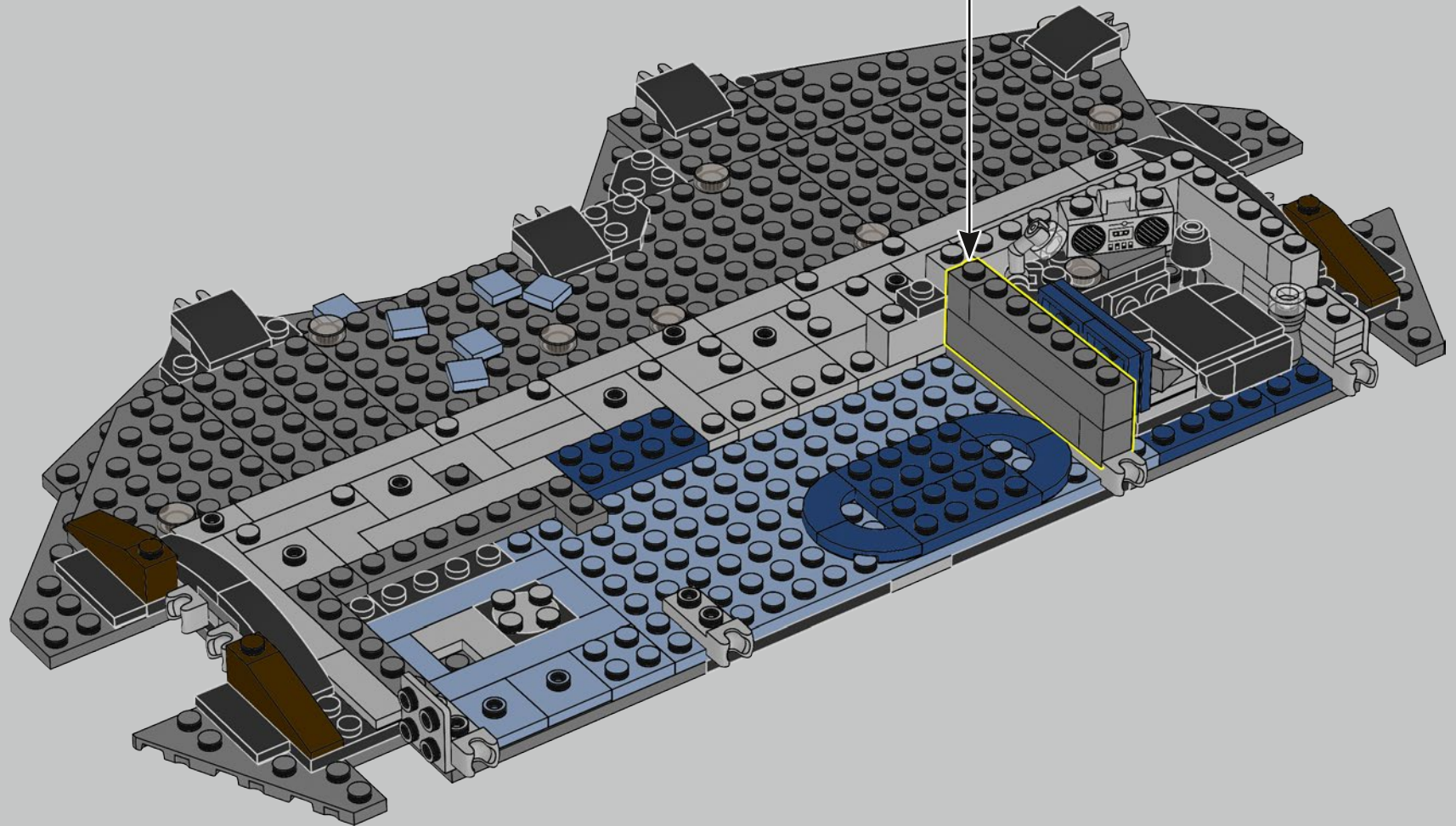
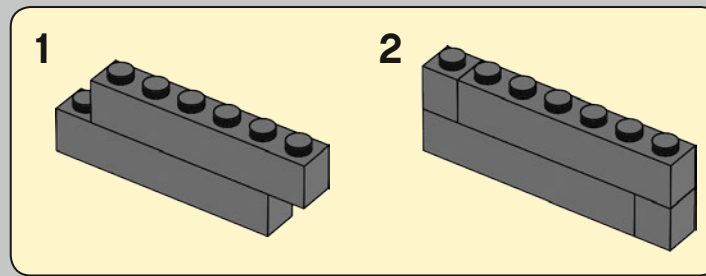

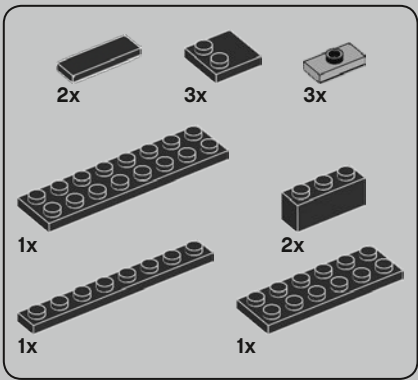

167

1

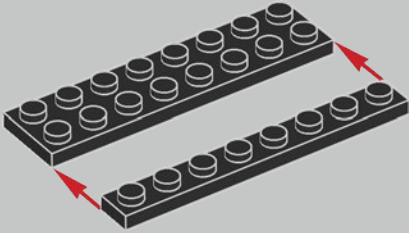

2

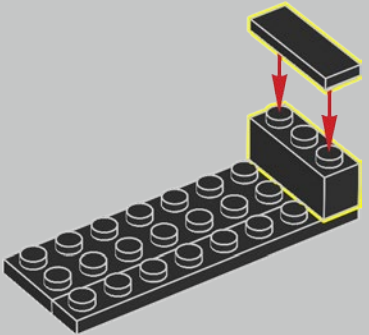

3

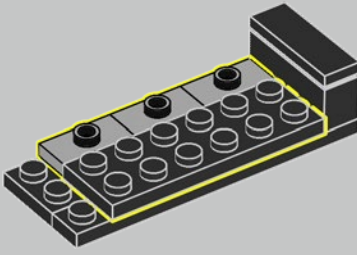

4

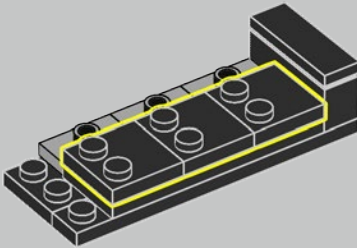

5

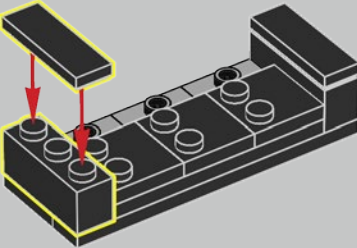

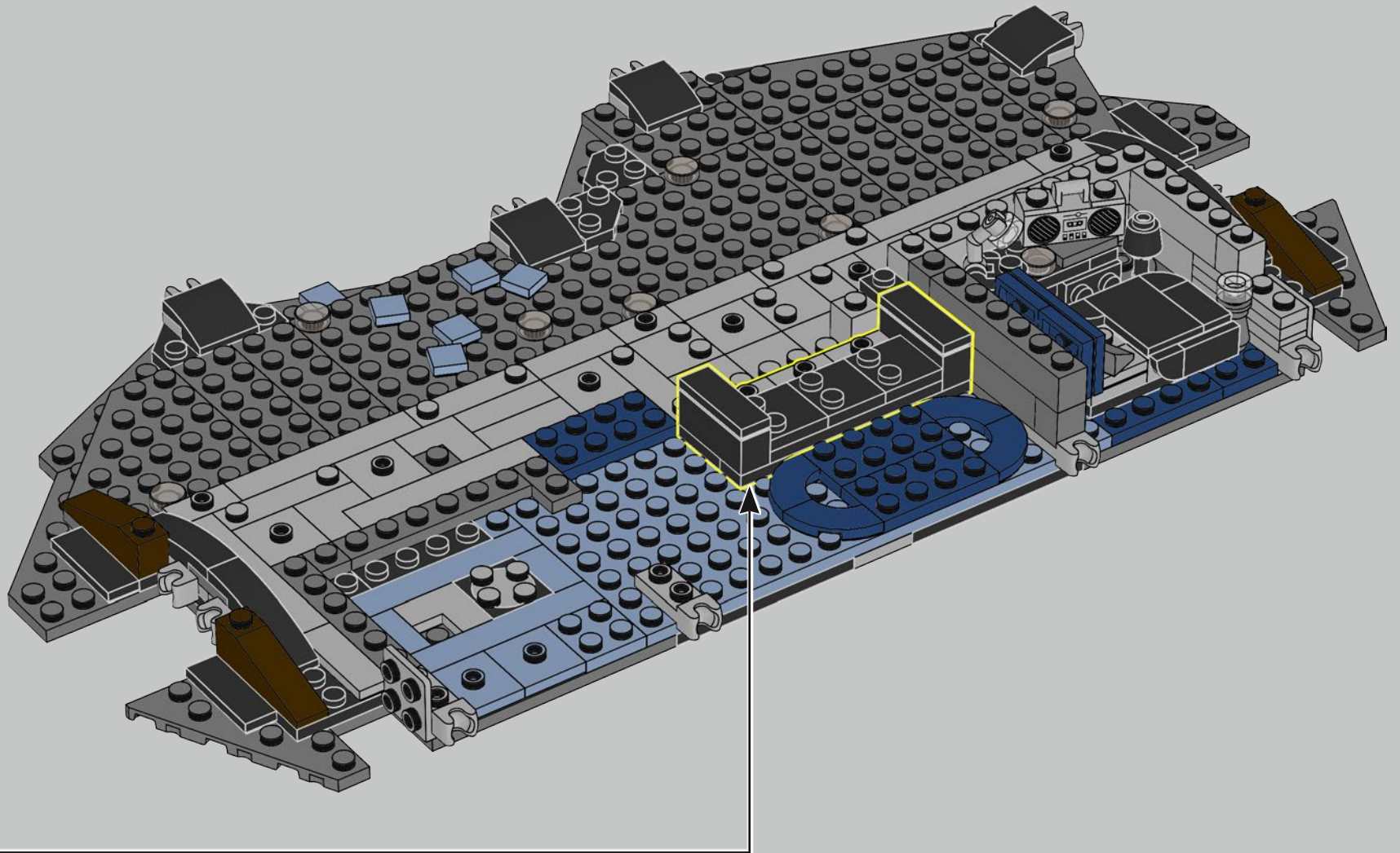

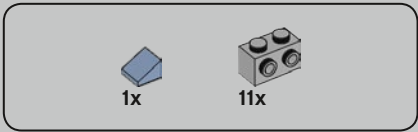

168

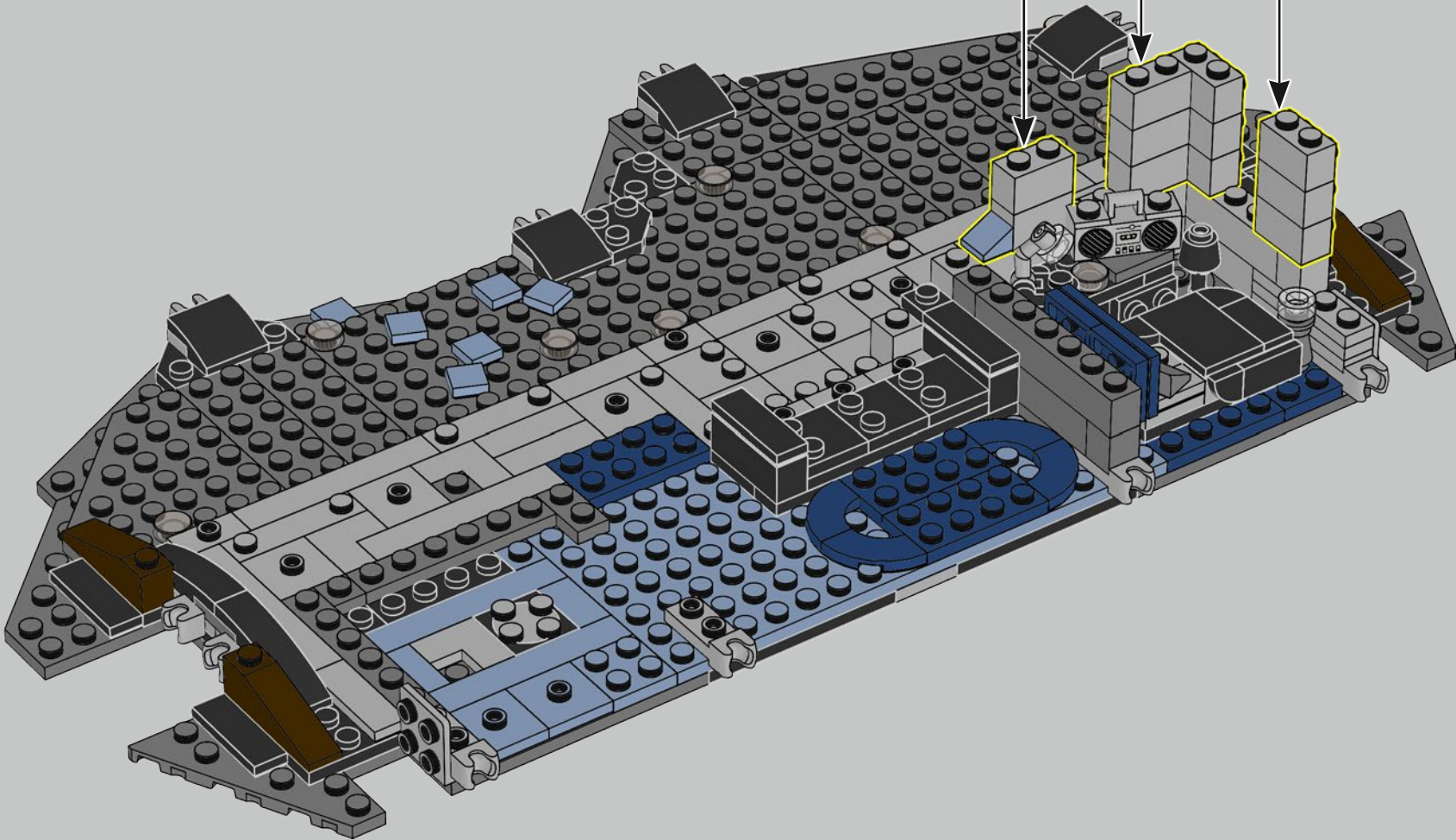
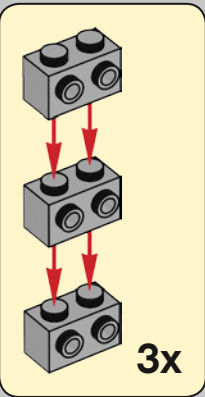
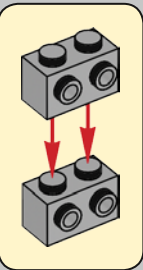

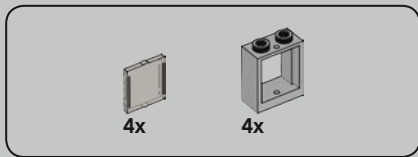

169

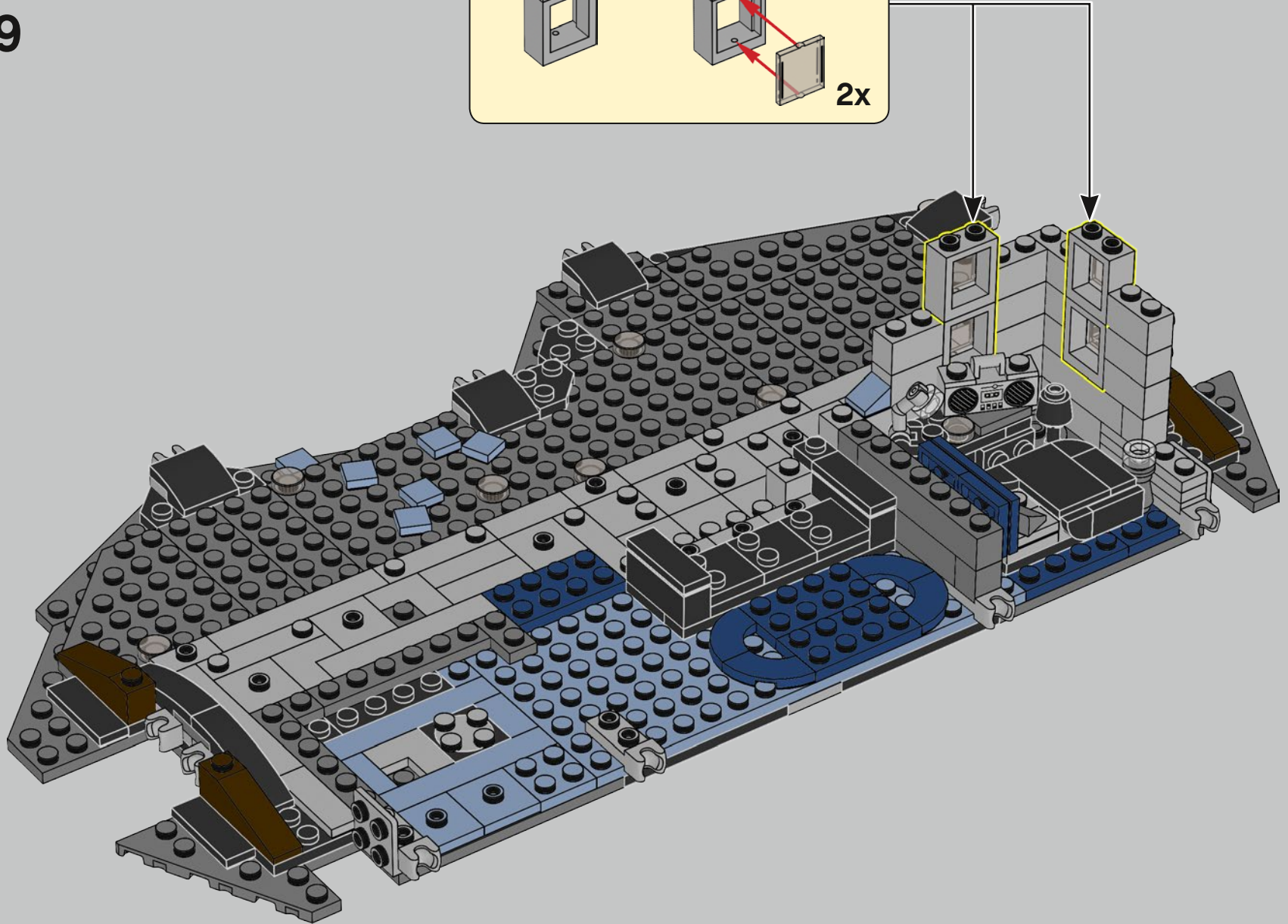
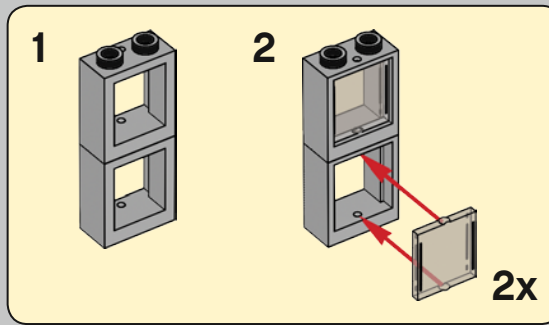

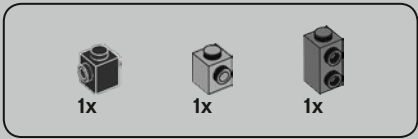

170

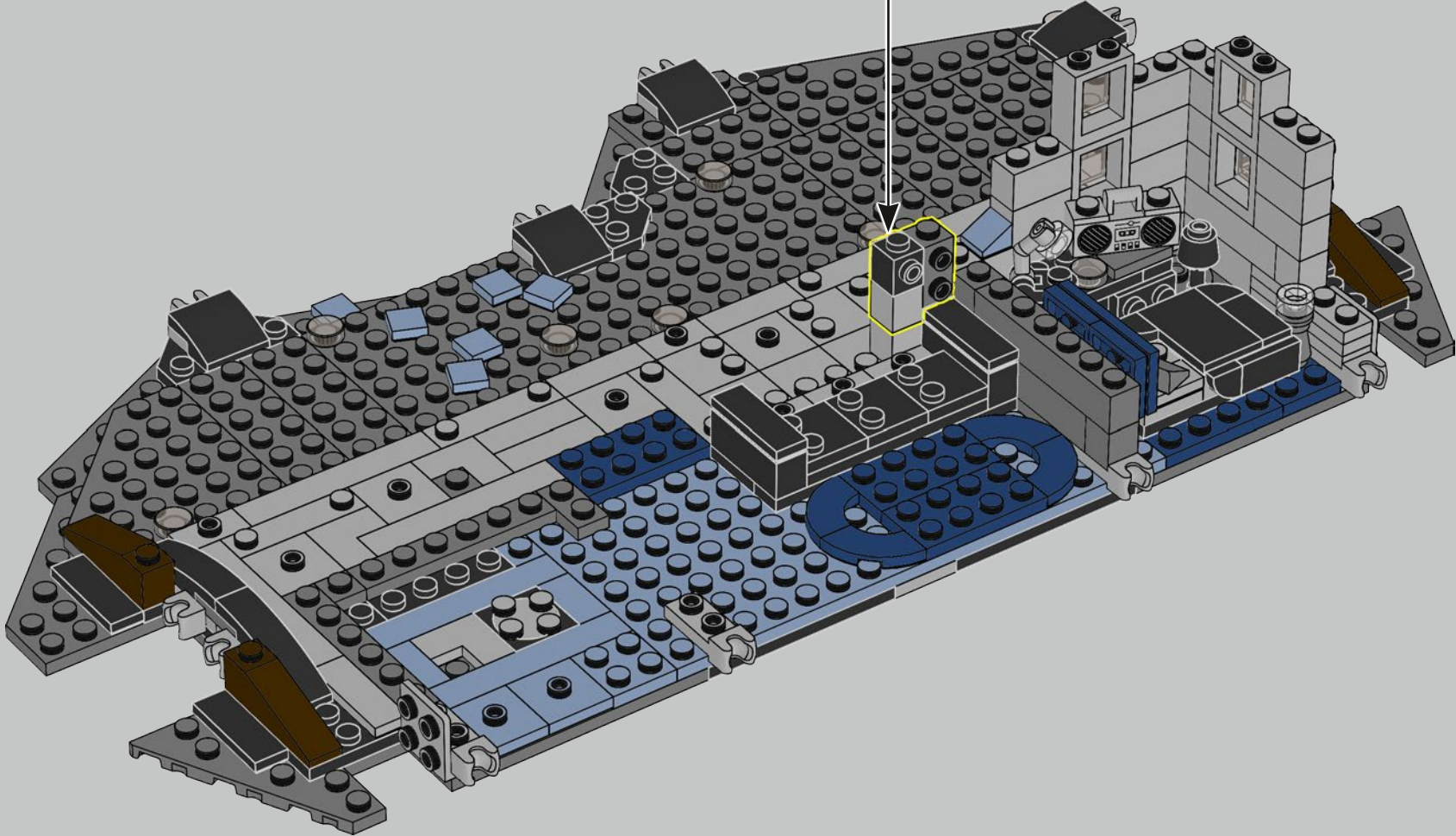
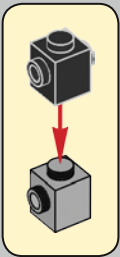

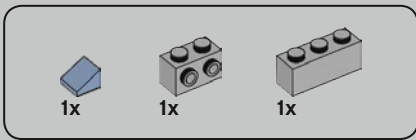

171

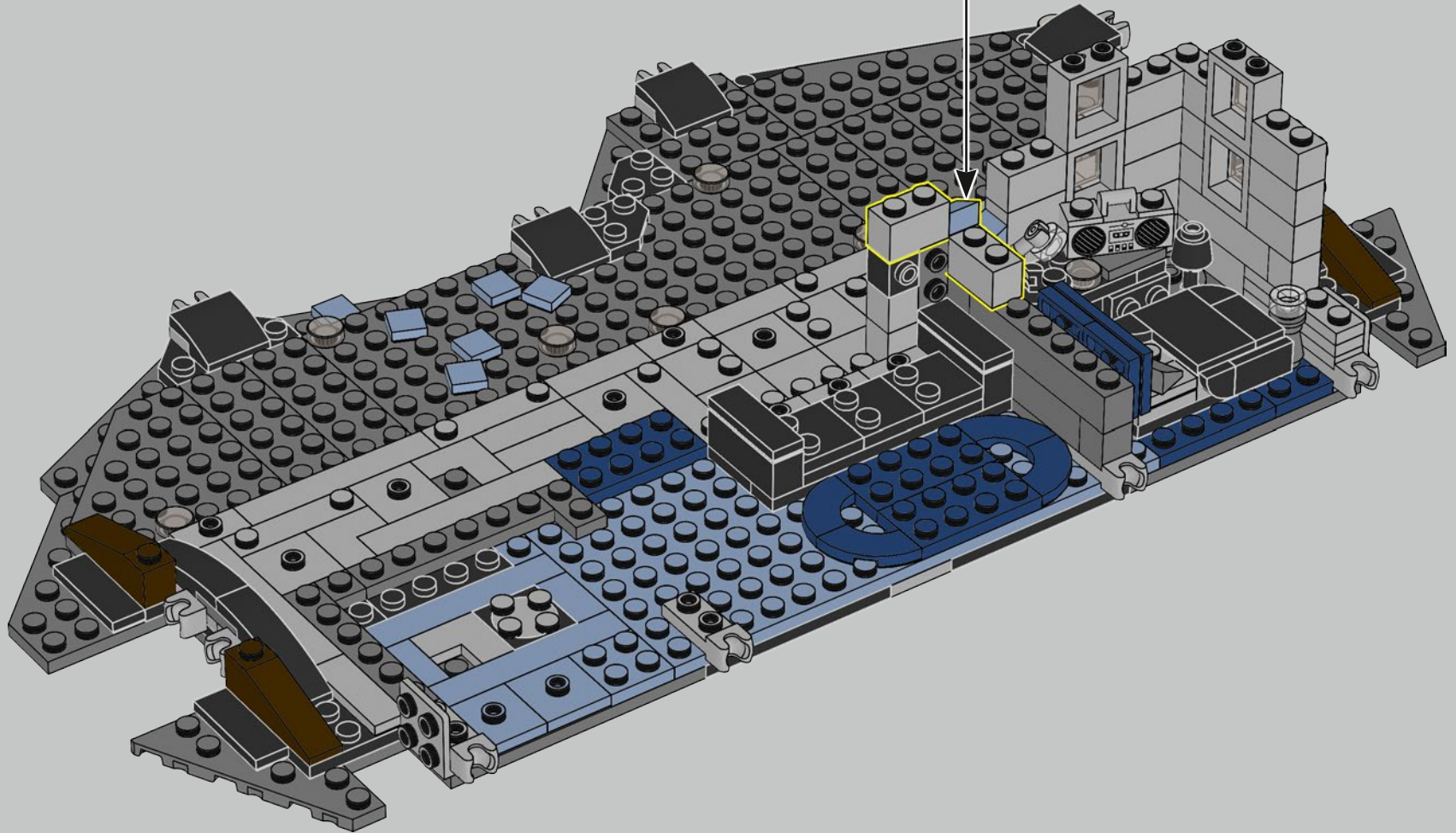
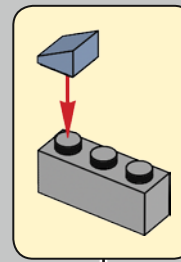

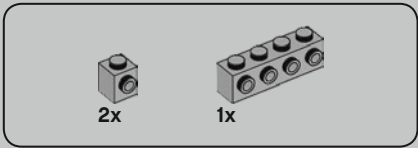

172

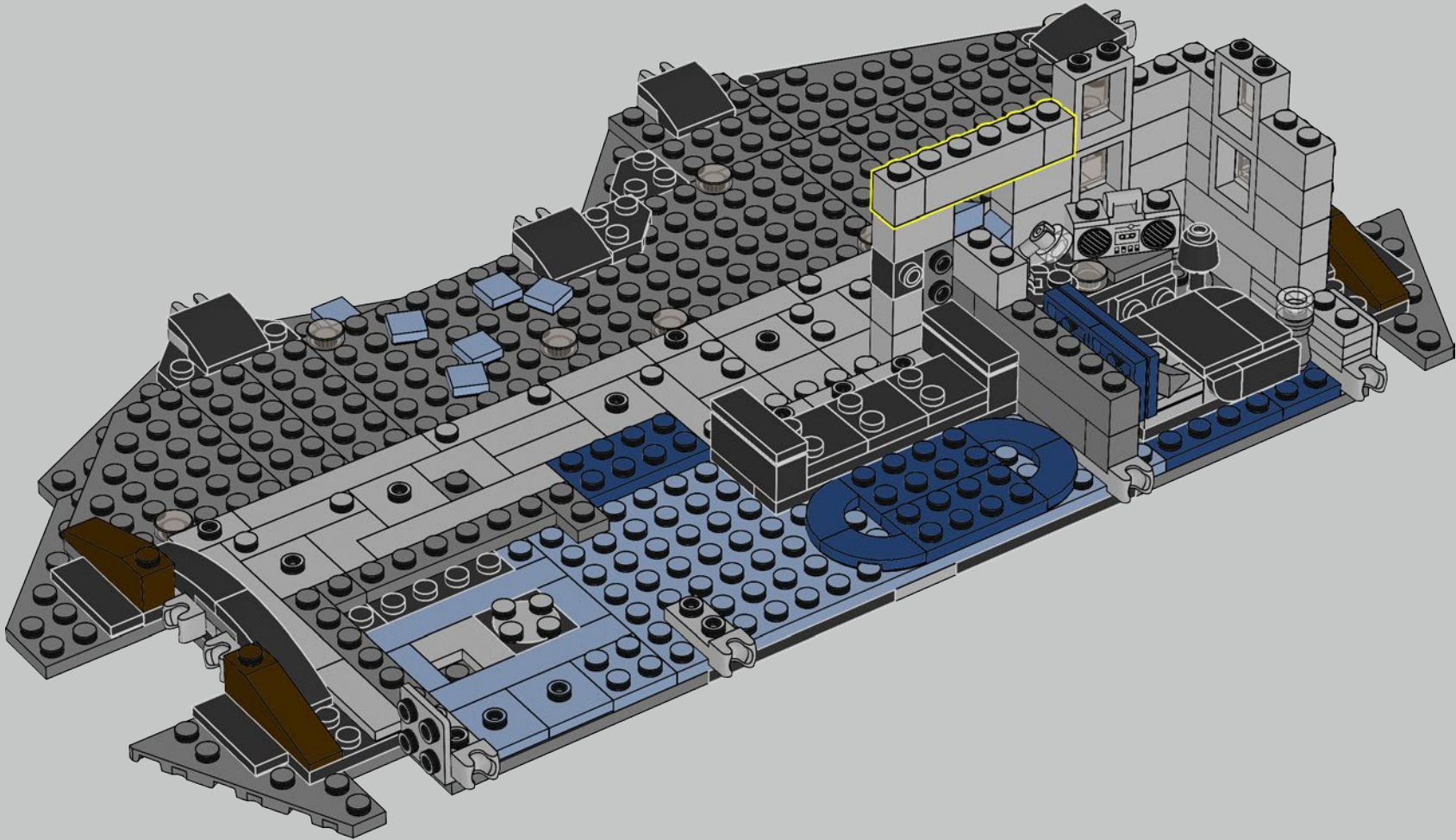

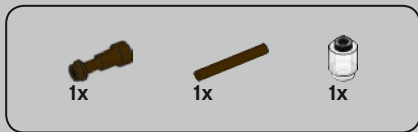

173

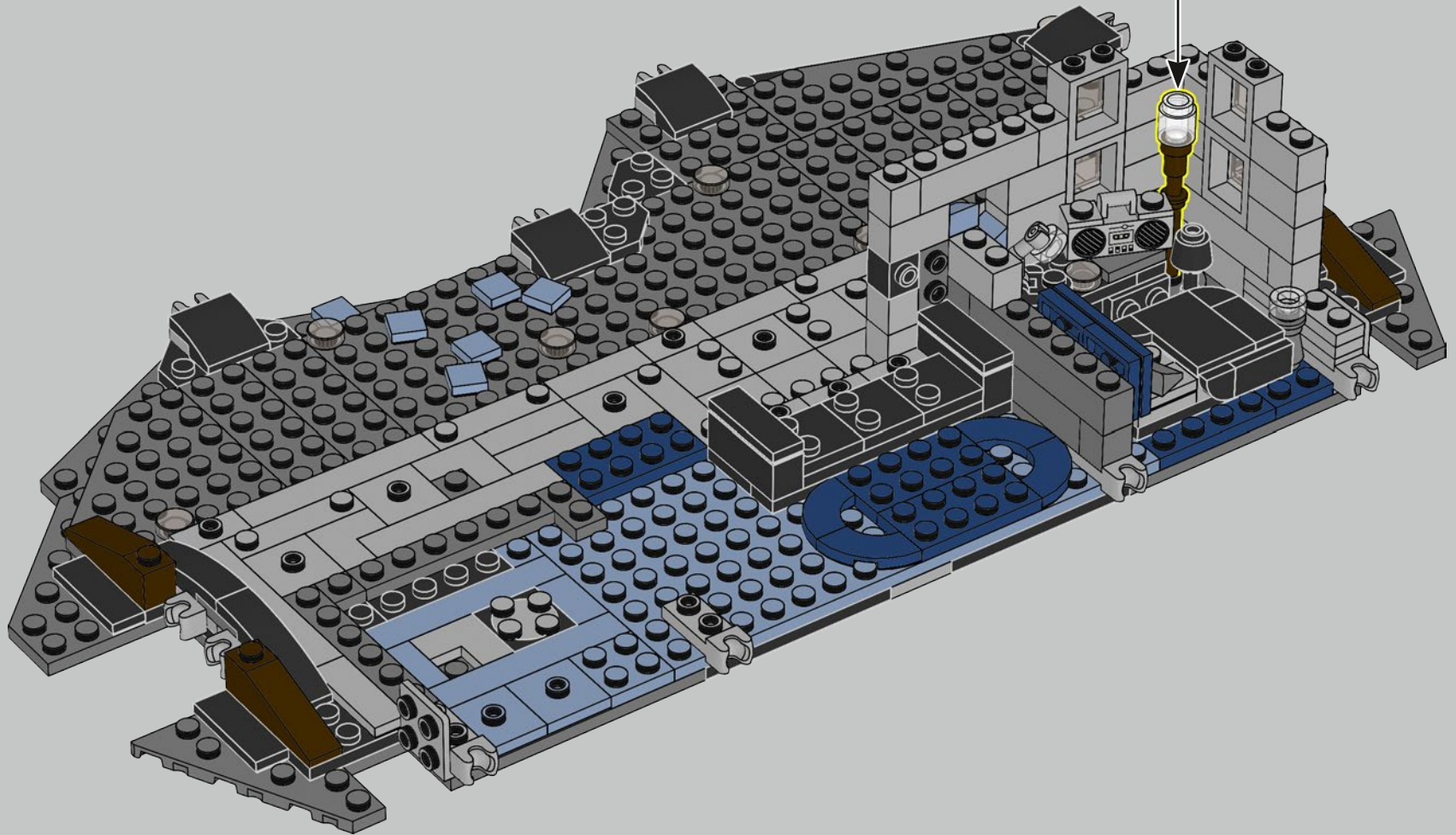
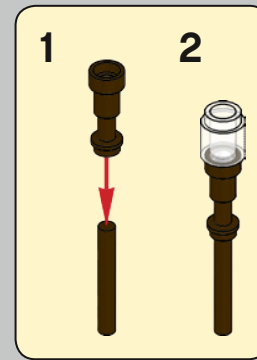



174

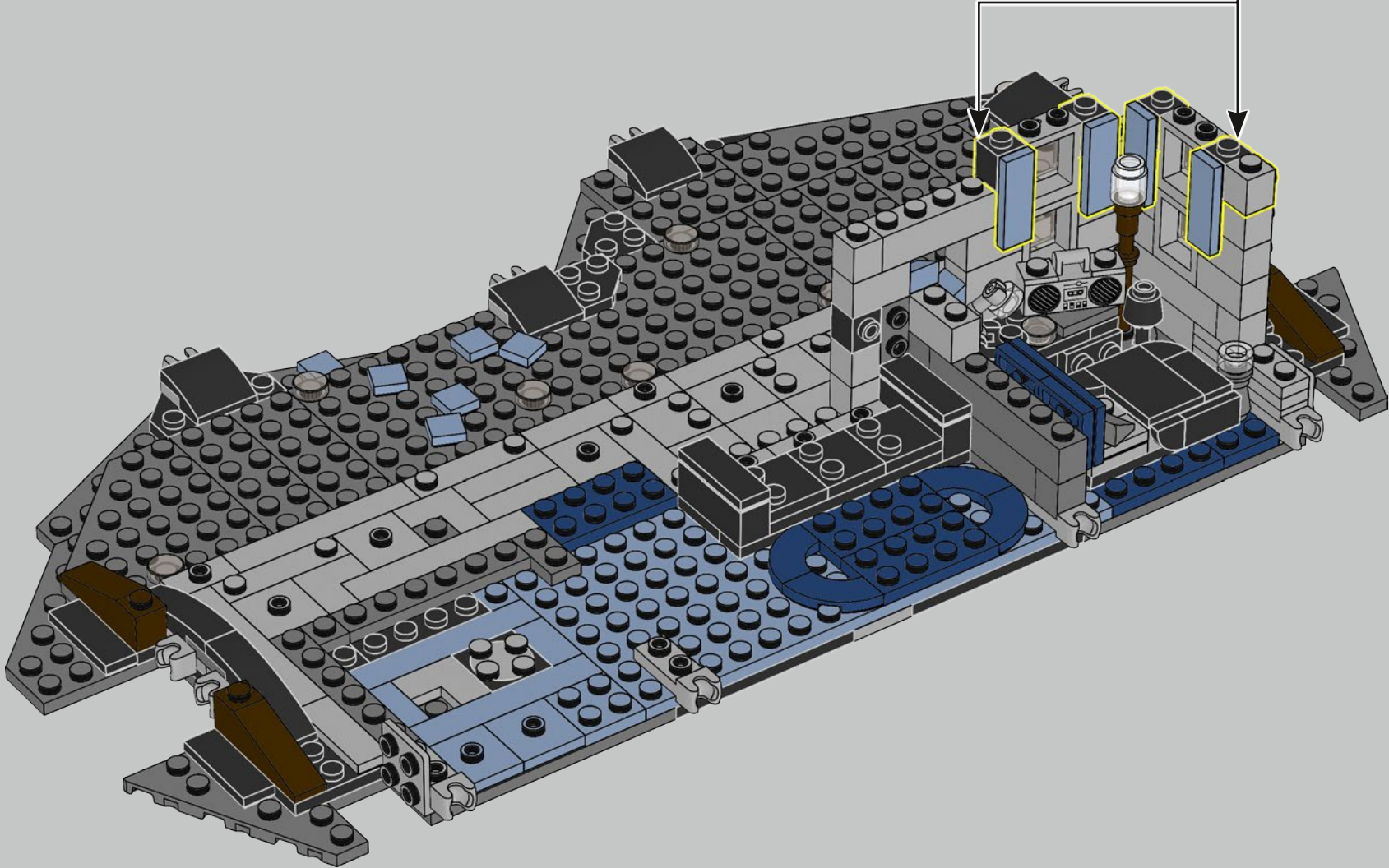
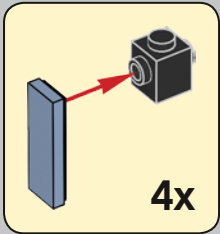

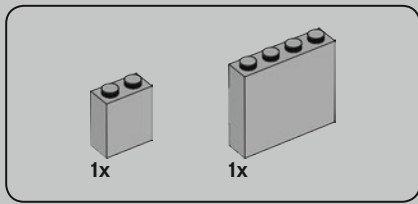

175

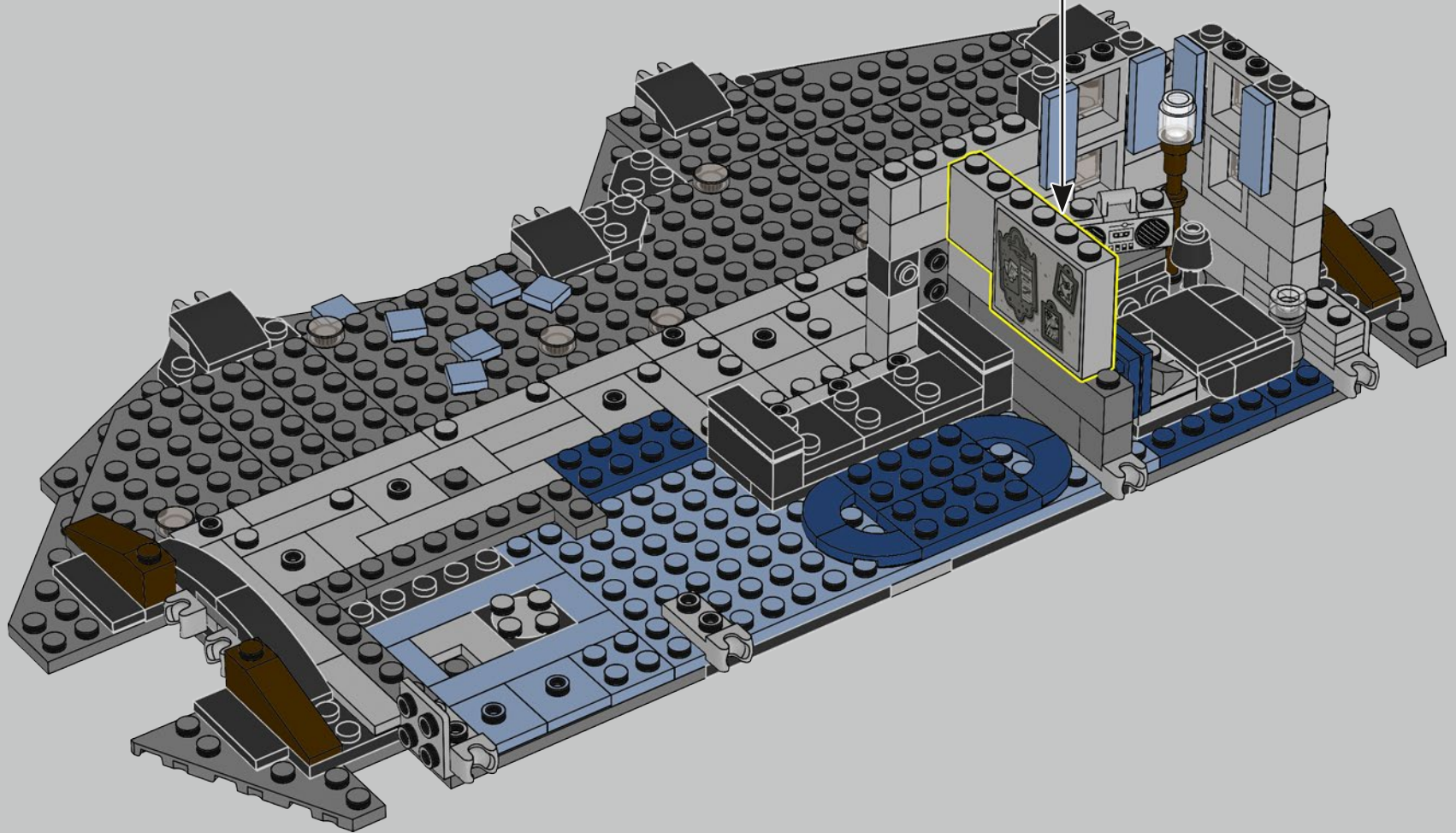
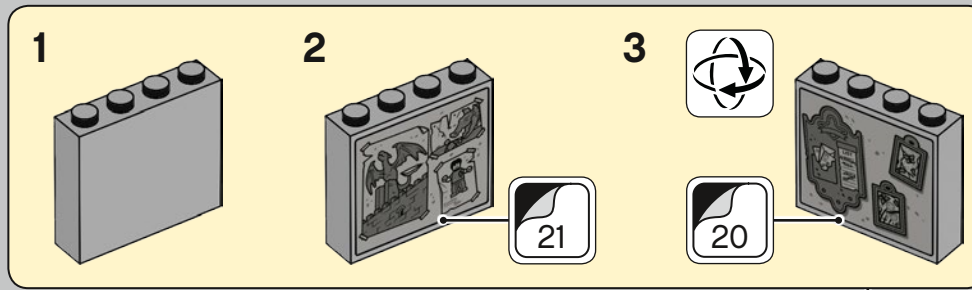

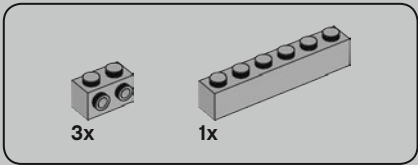

176

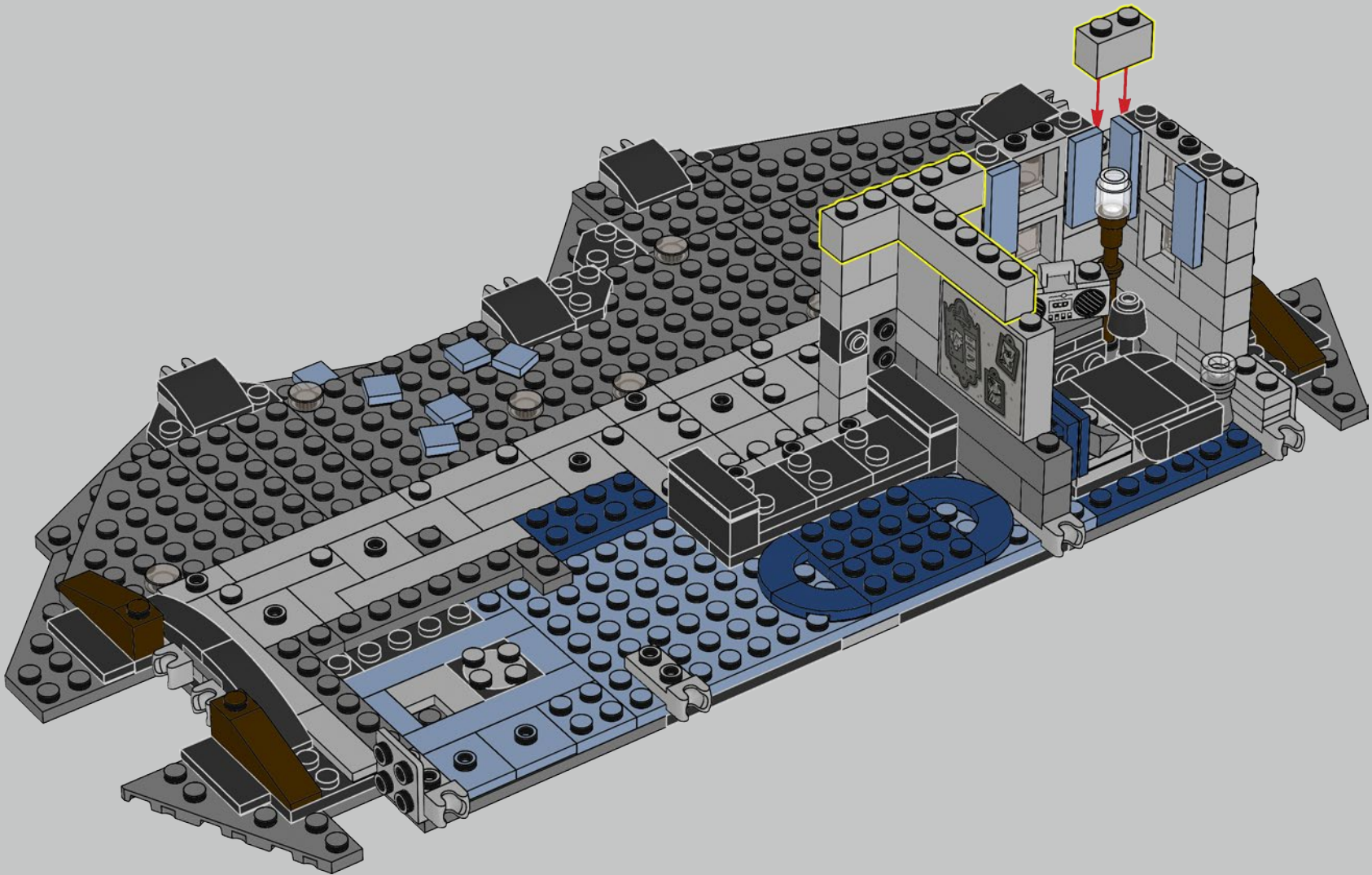

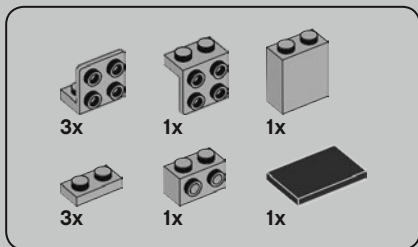

177

1

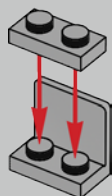

2

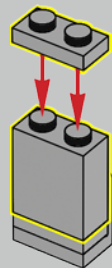

3

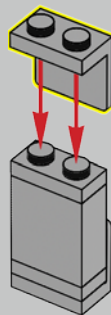

4

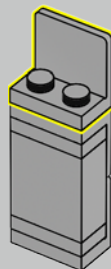

5

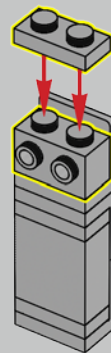

6

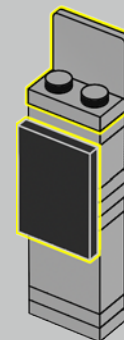

7



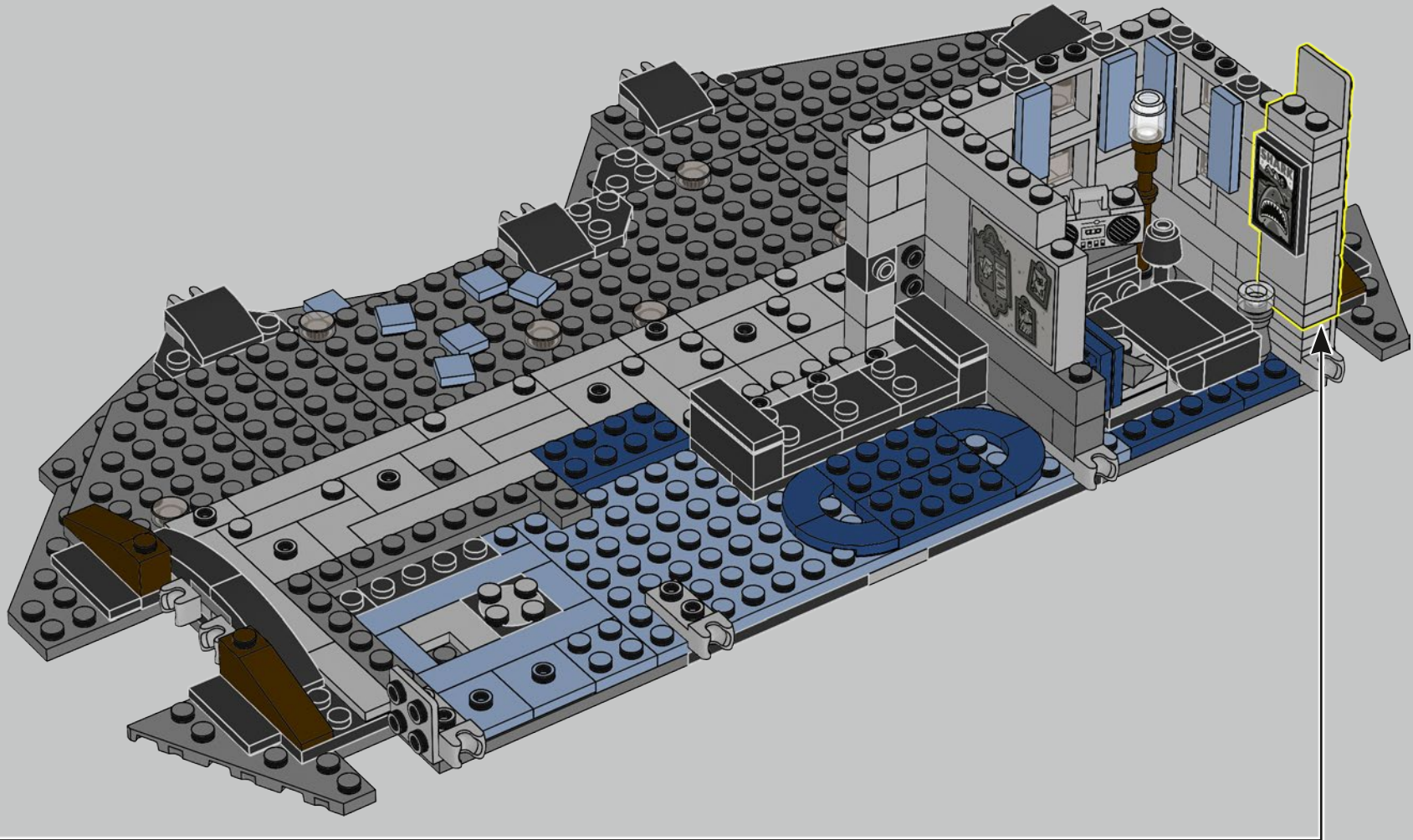

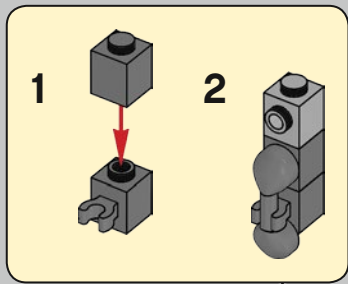
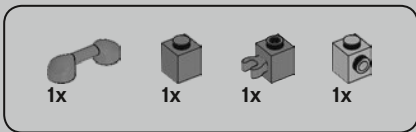

178

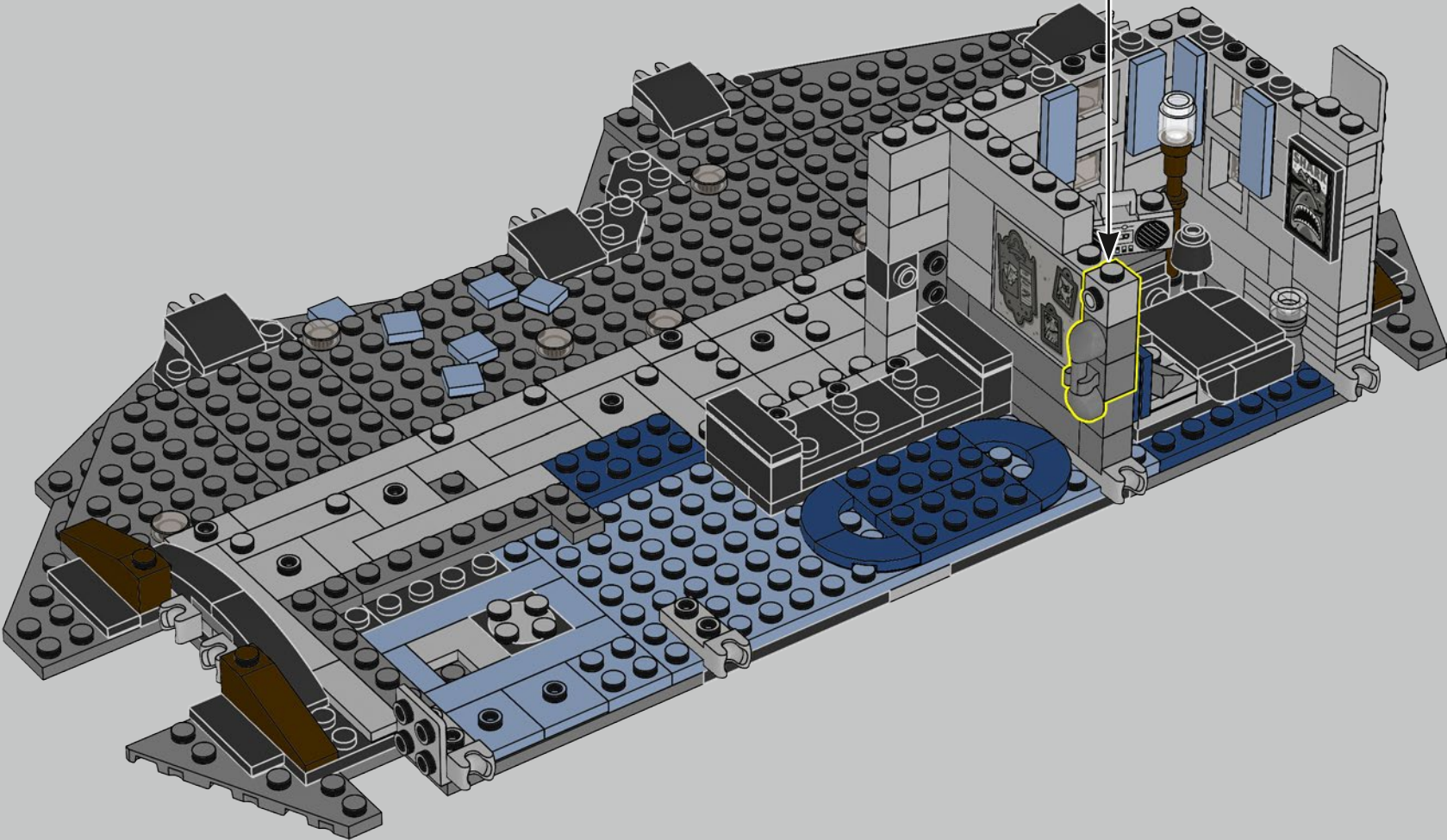

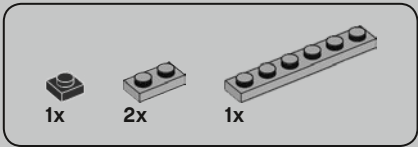

179

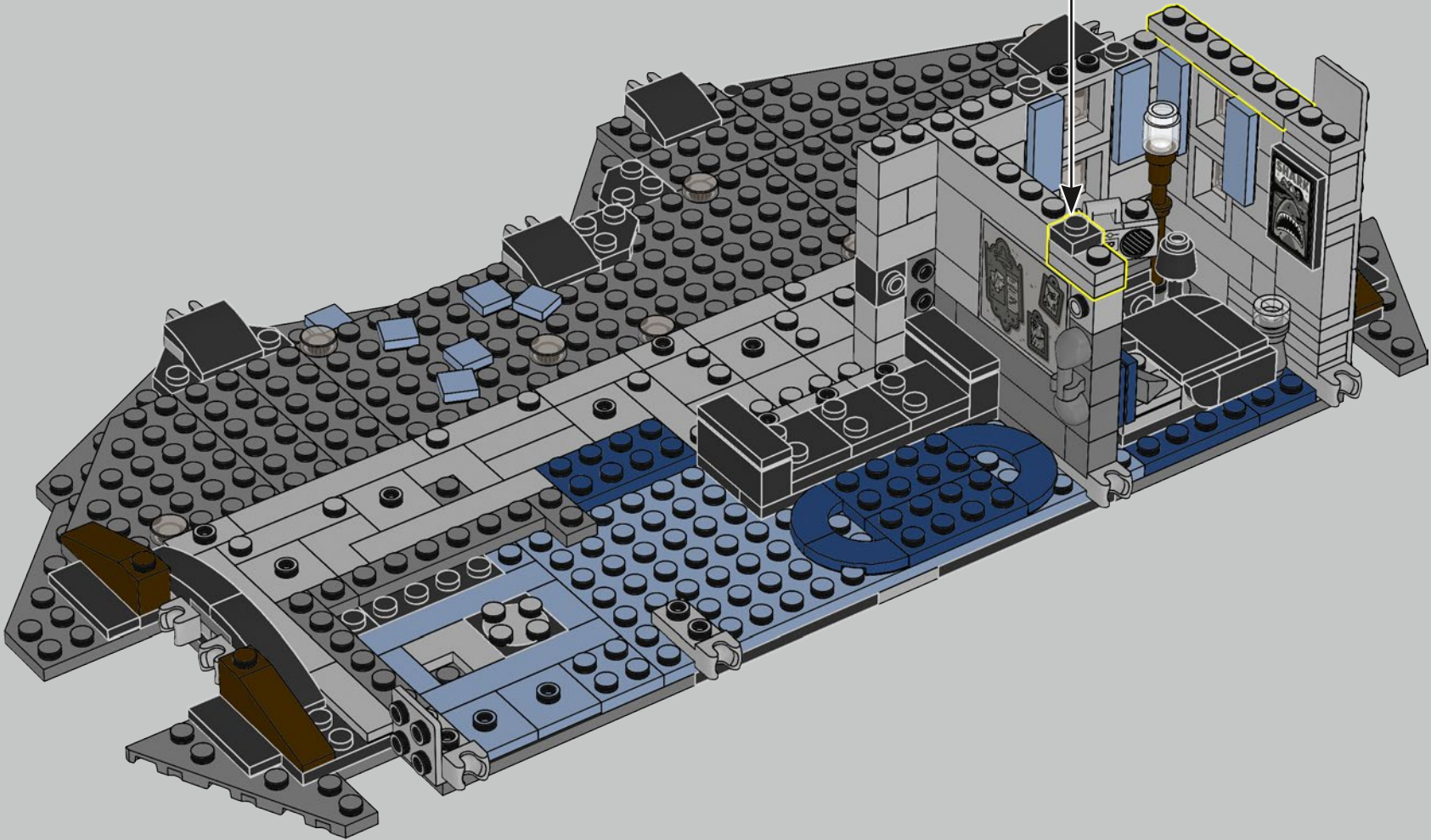
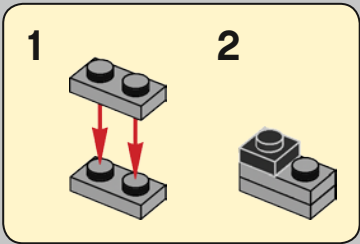

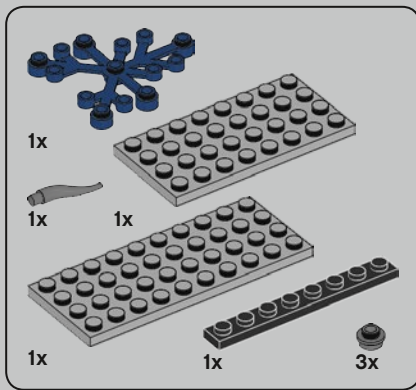

180

1

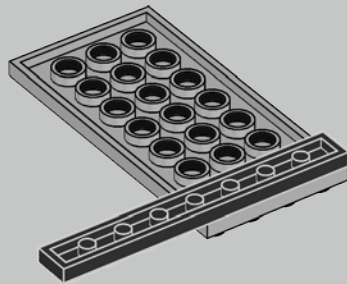

2

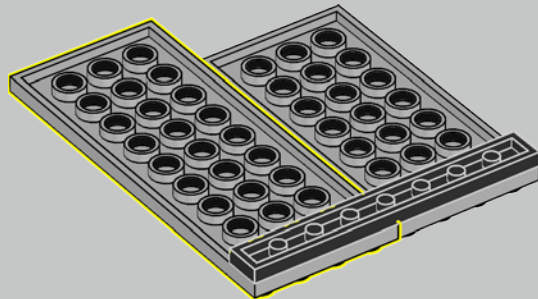

3

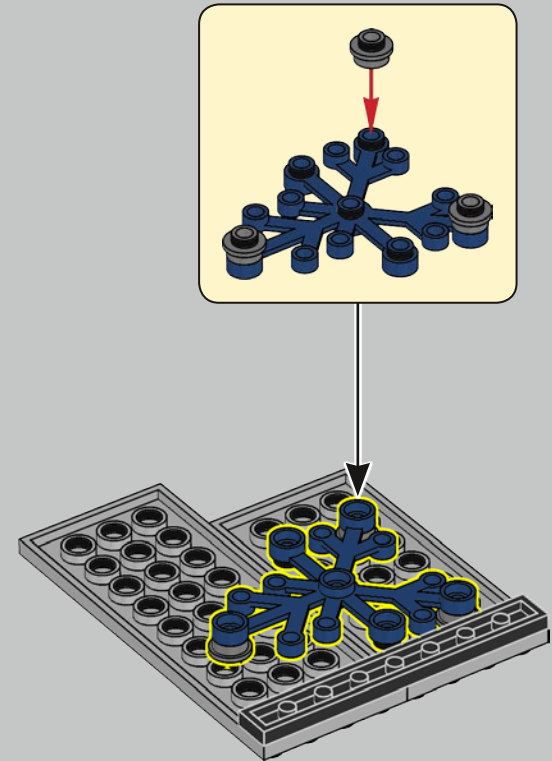

4

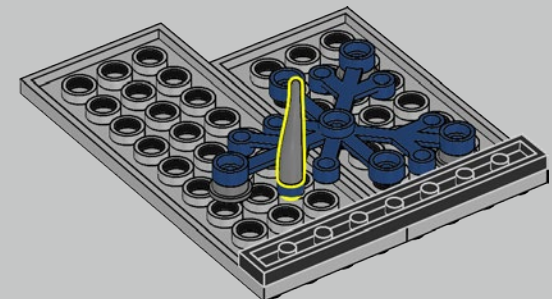

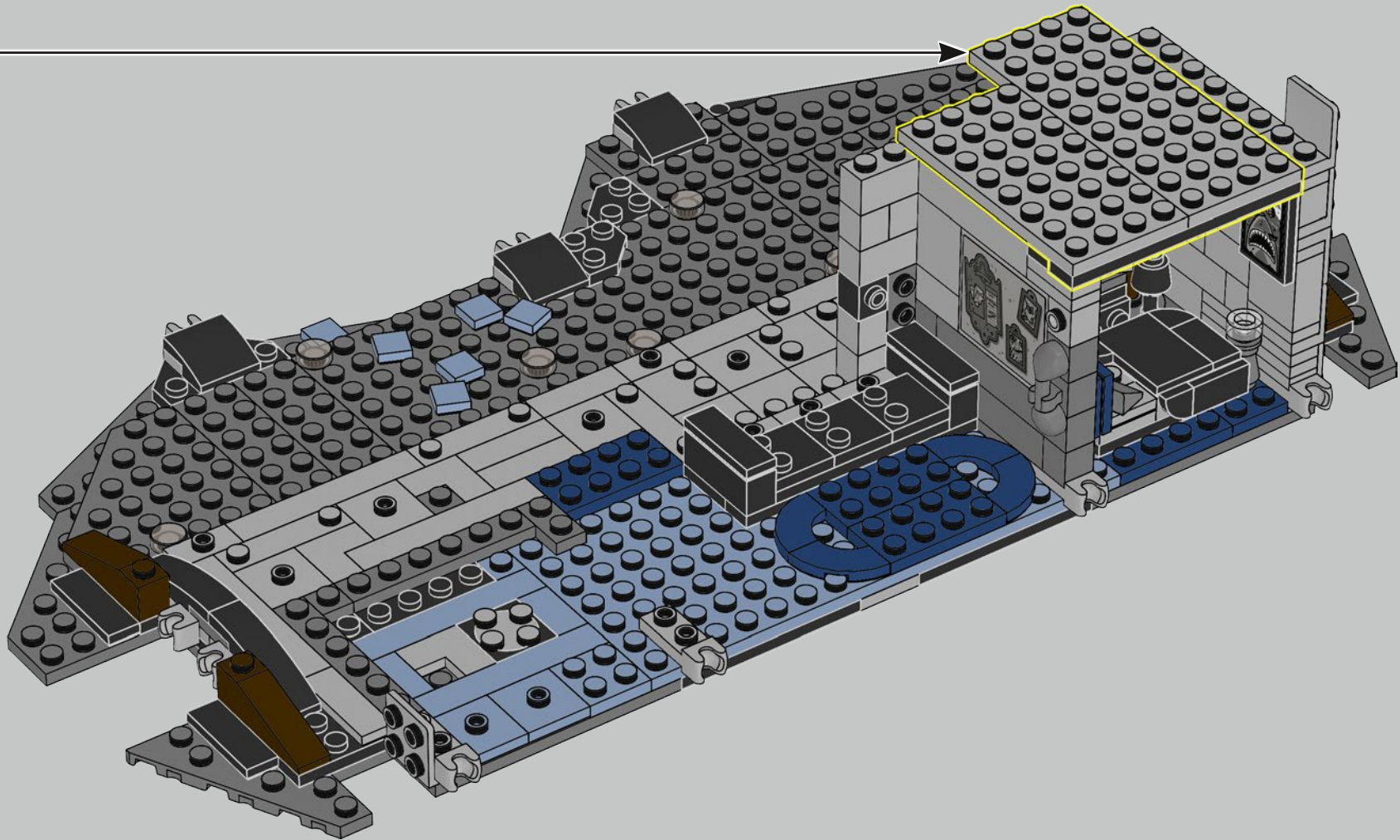

1x  2x 

181

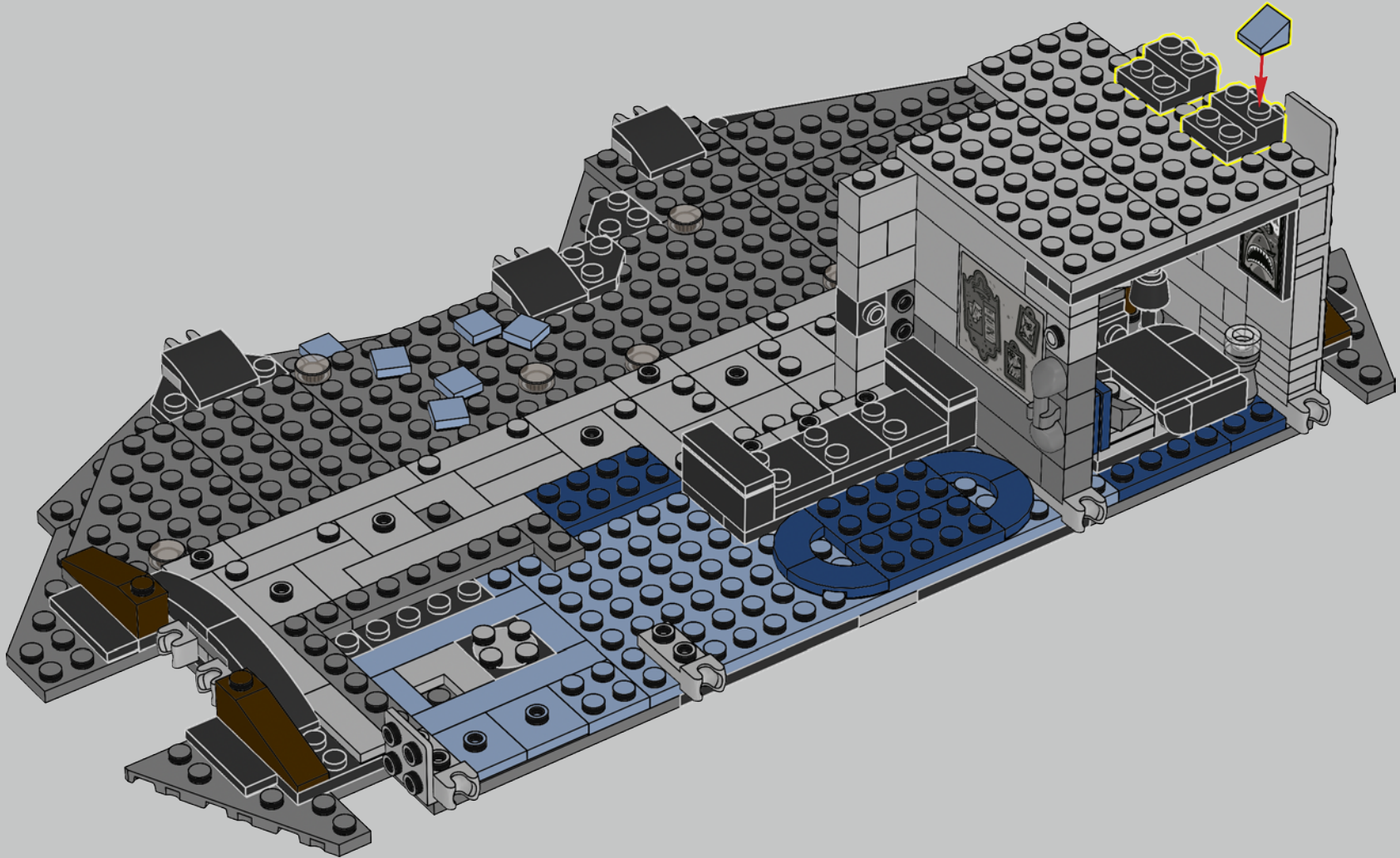

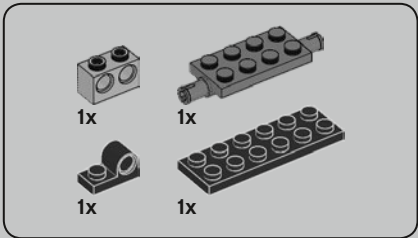

182

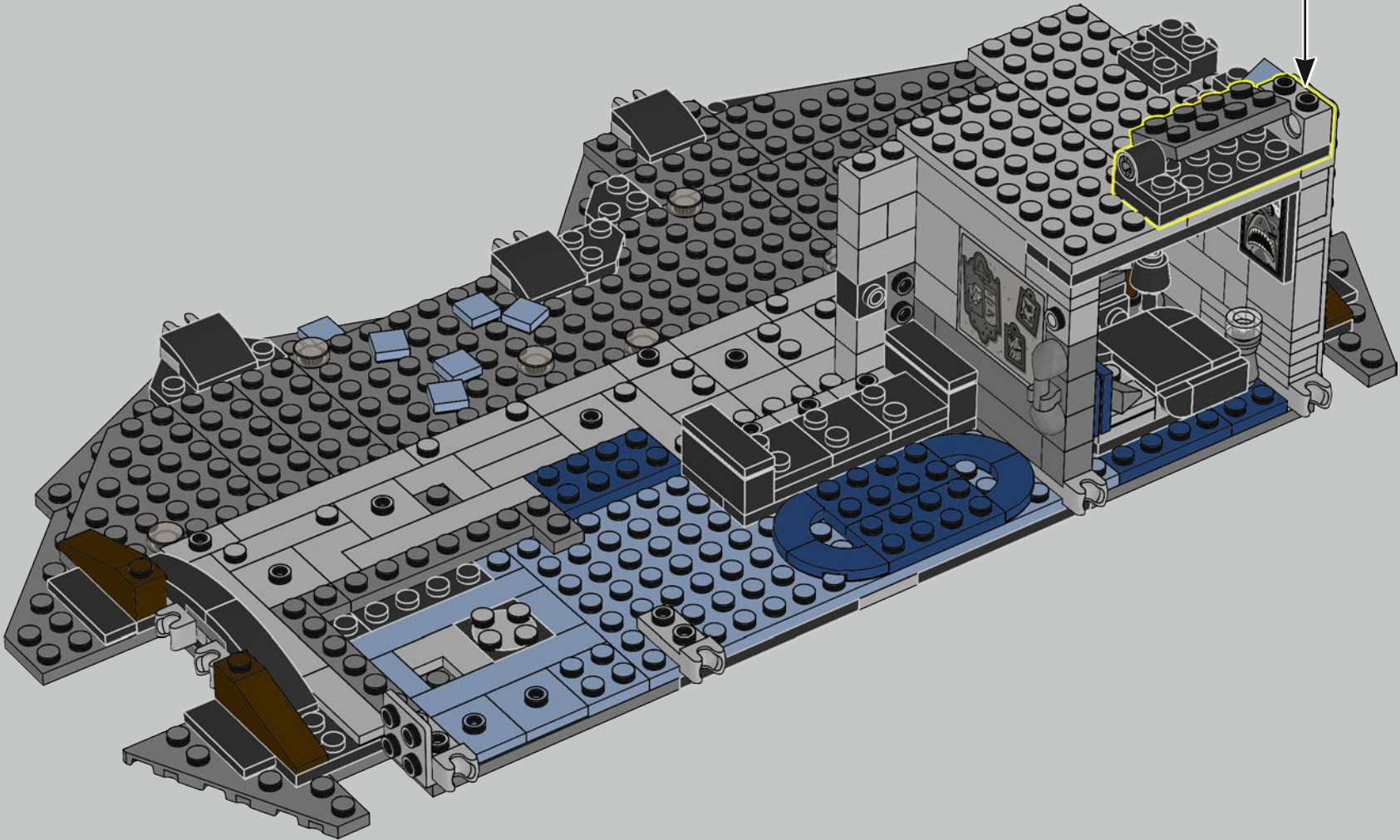
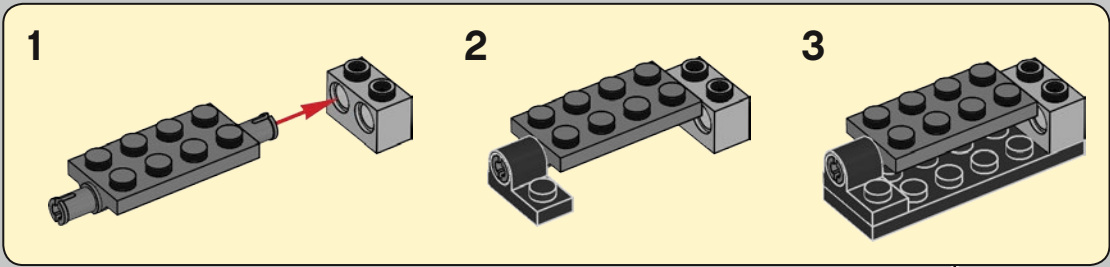

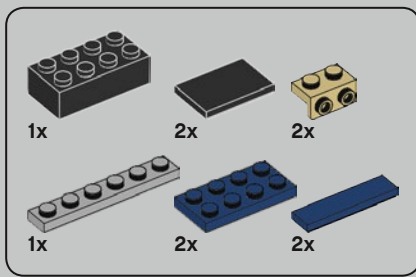

183

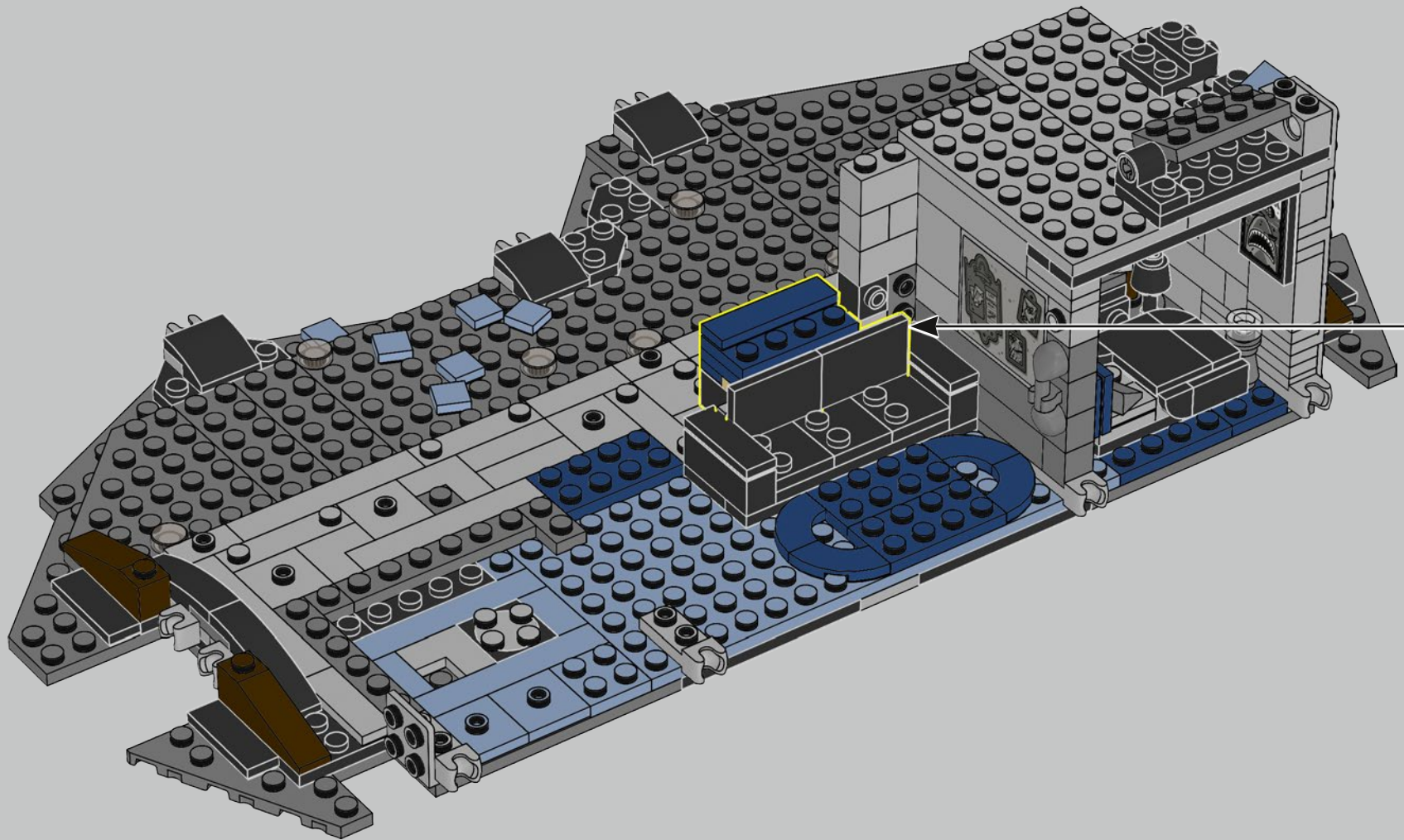
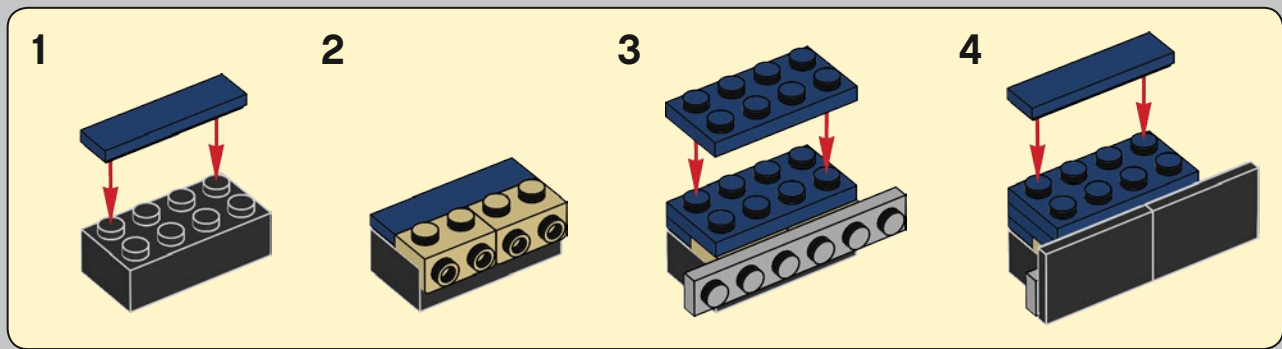

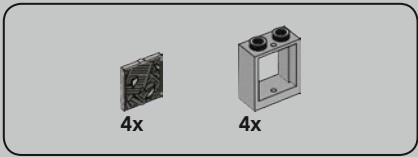

184

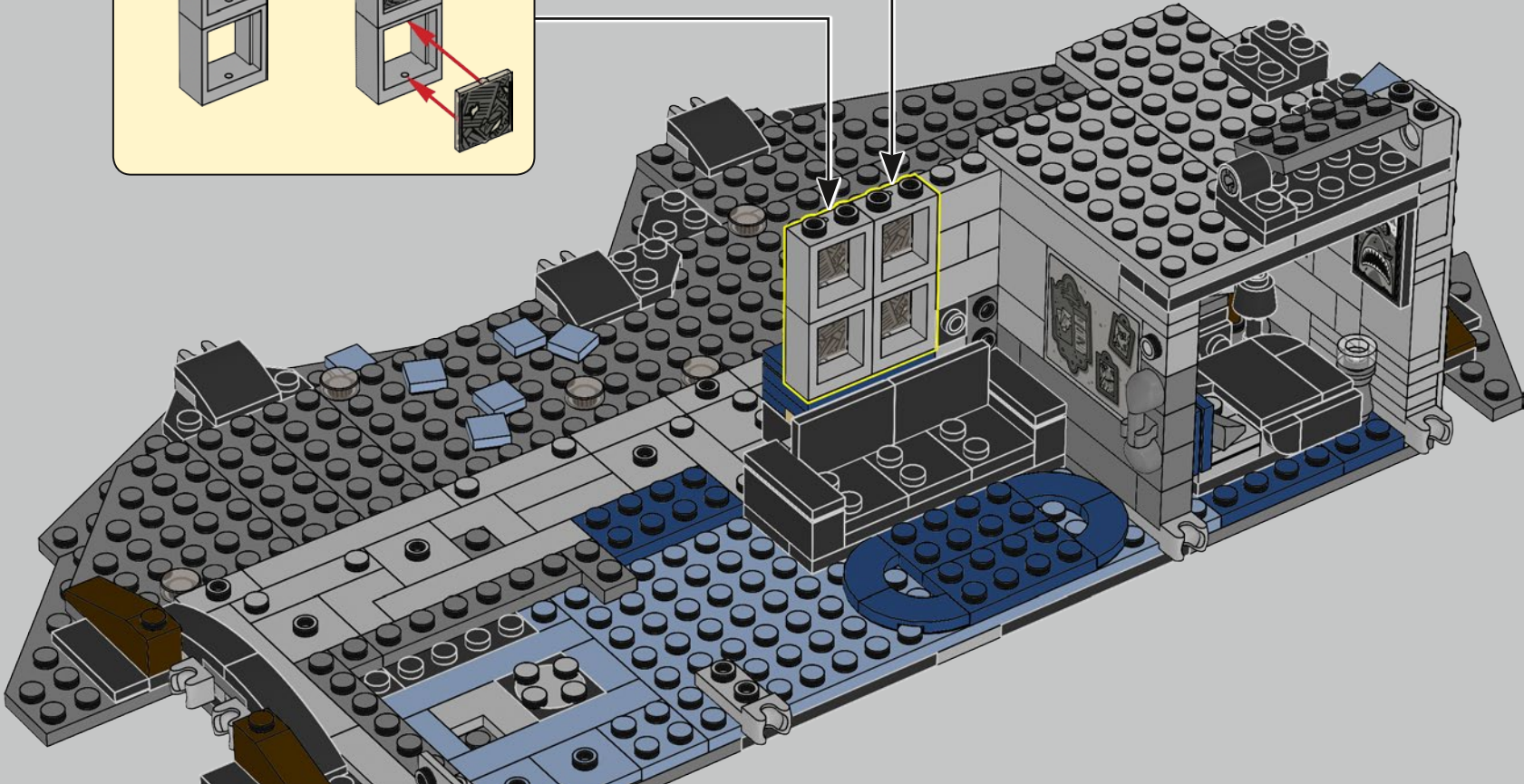
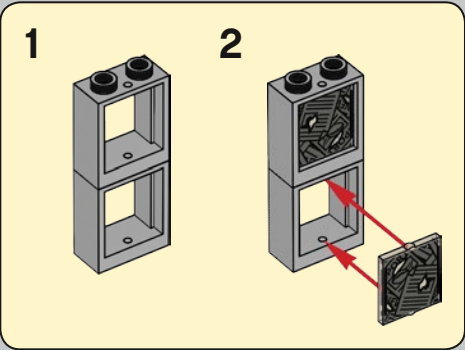
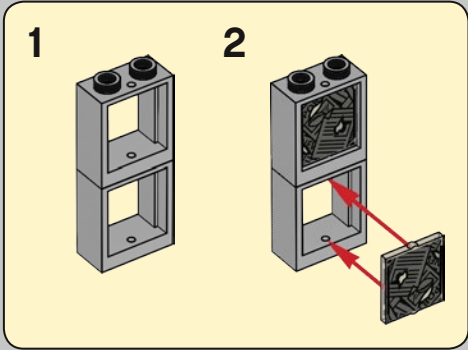

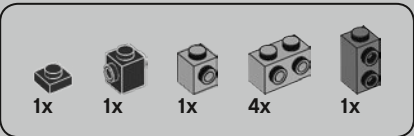

185

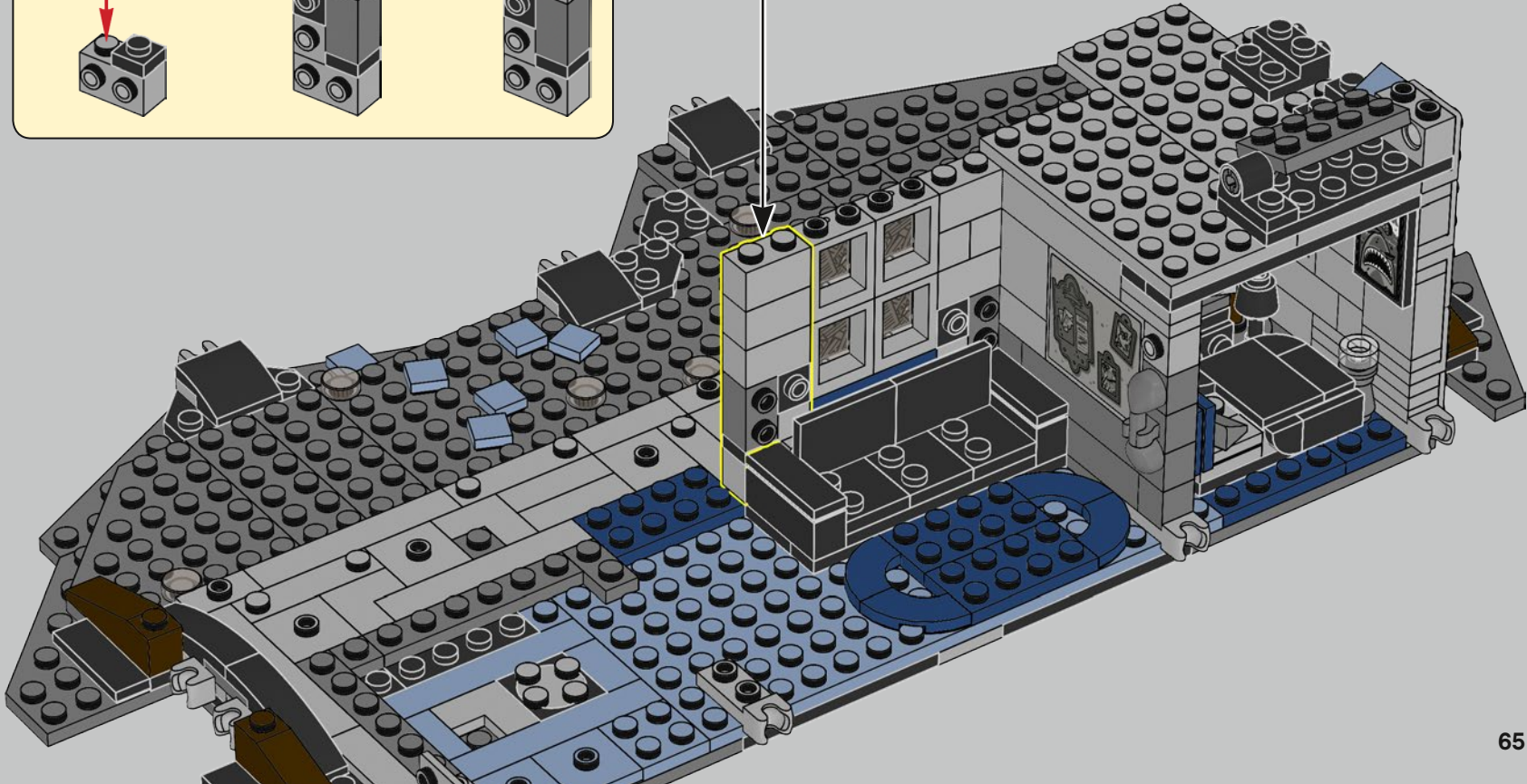
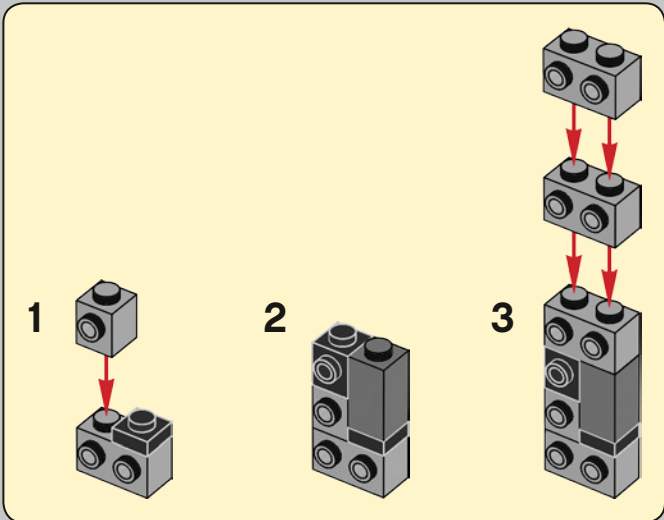

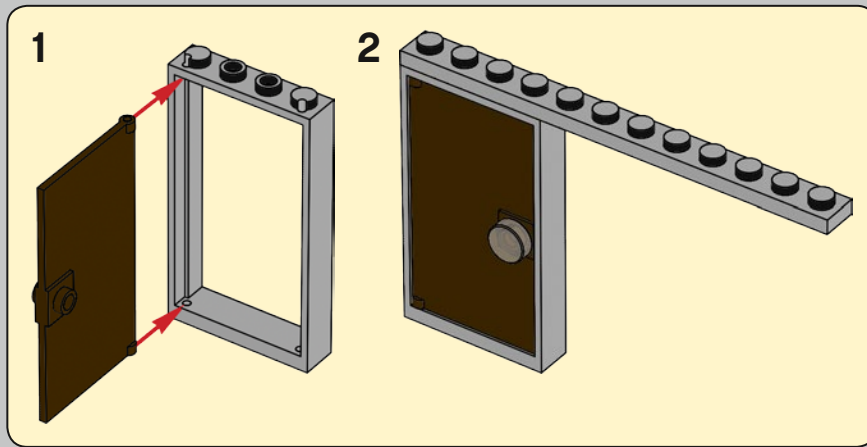
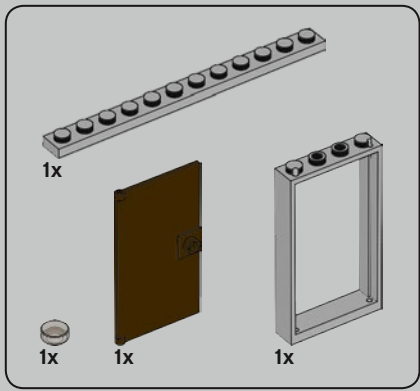

186

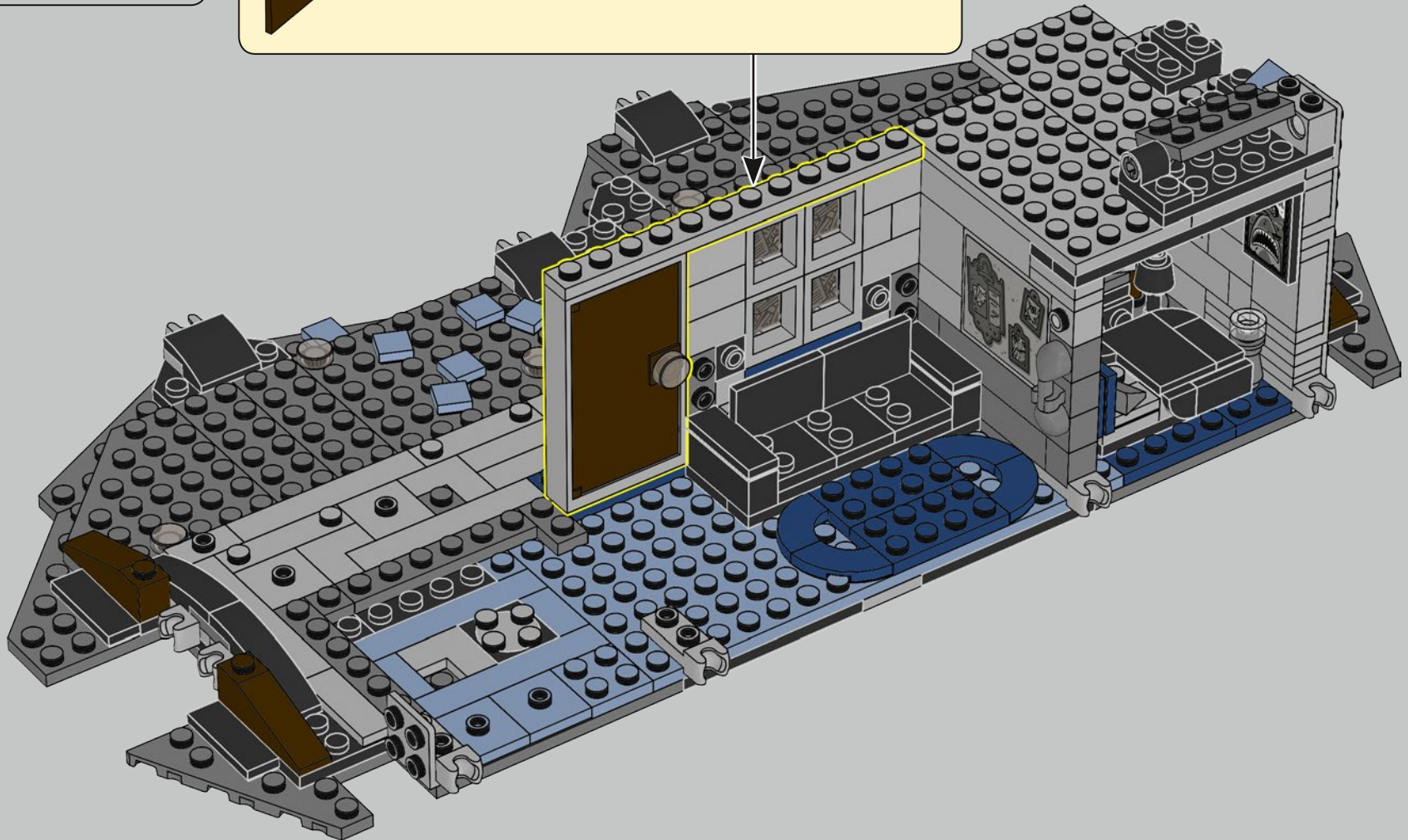

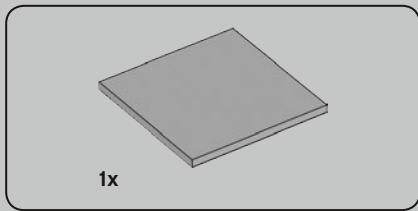

187

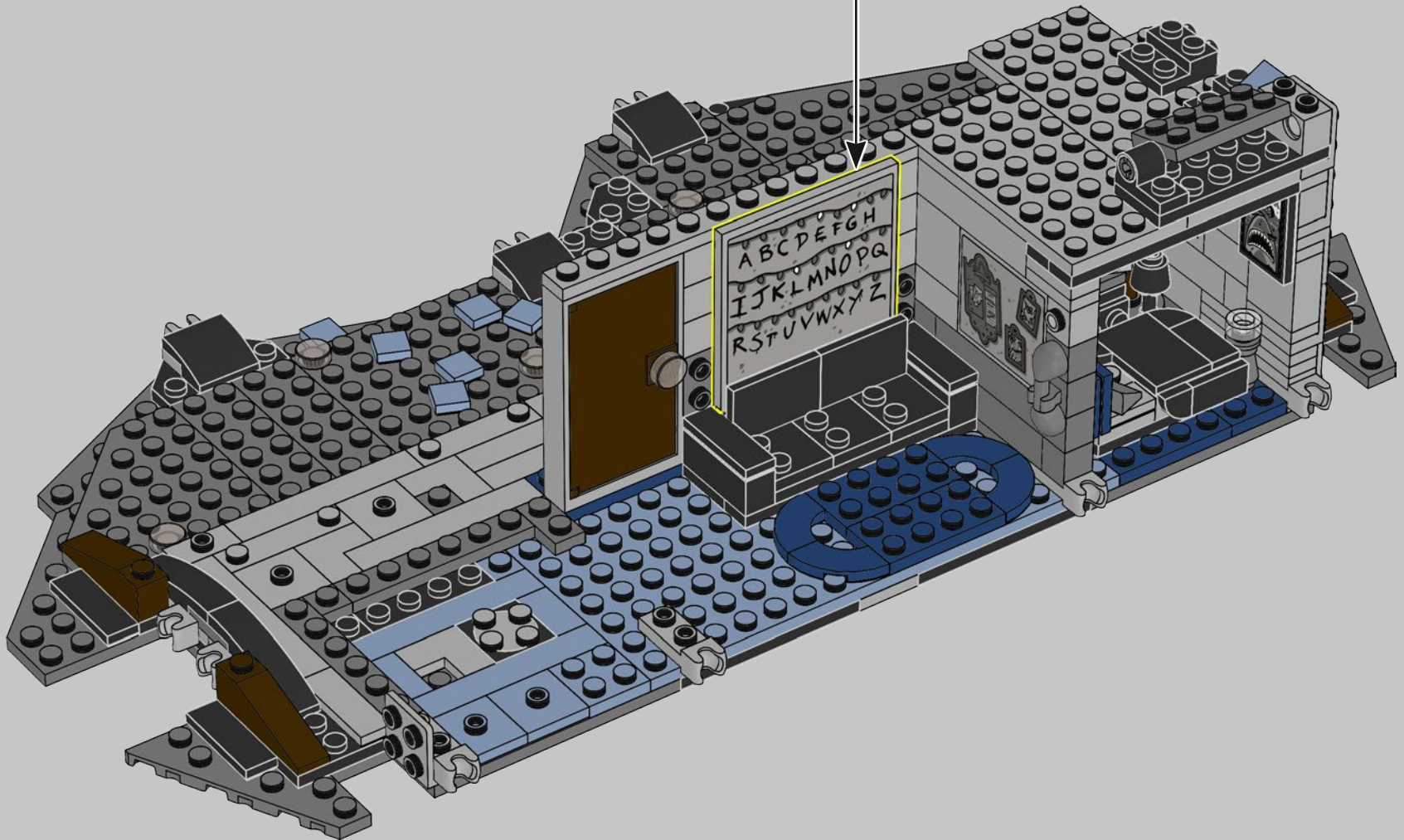
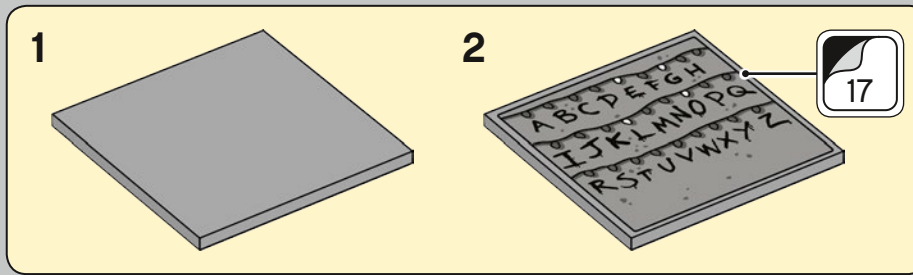

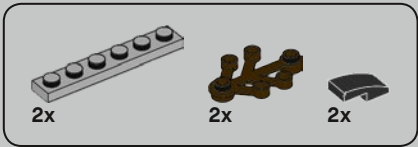

188

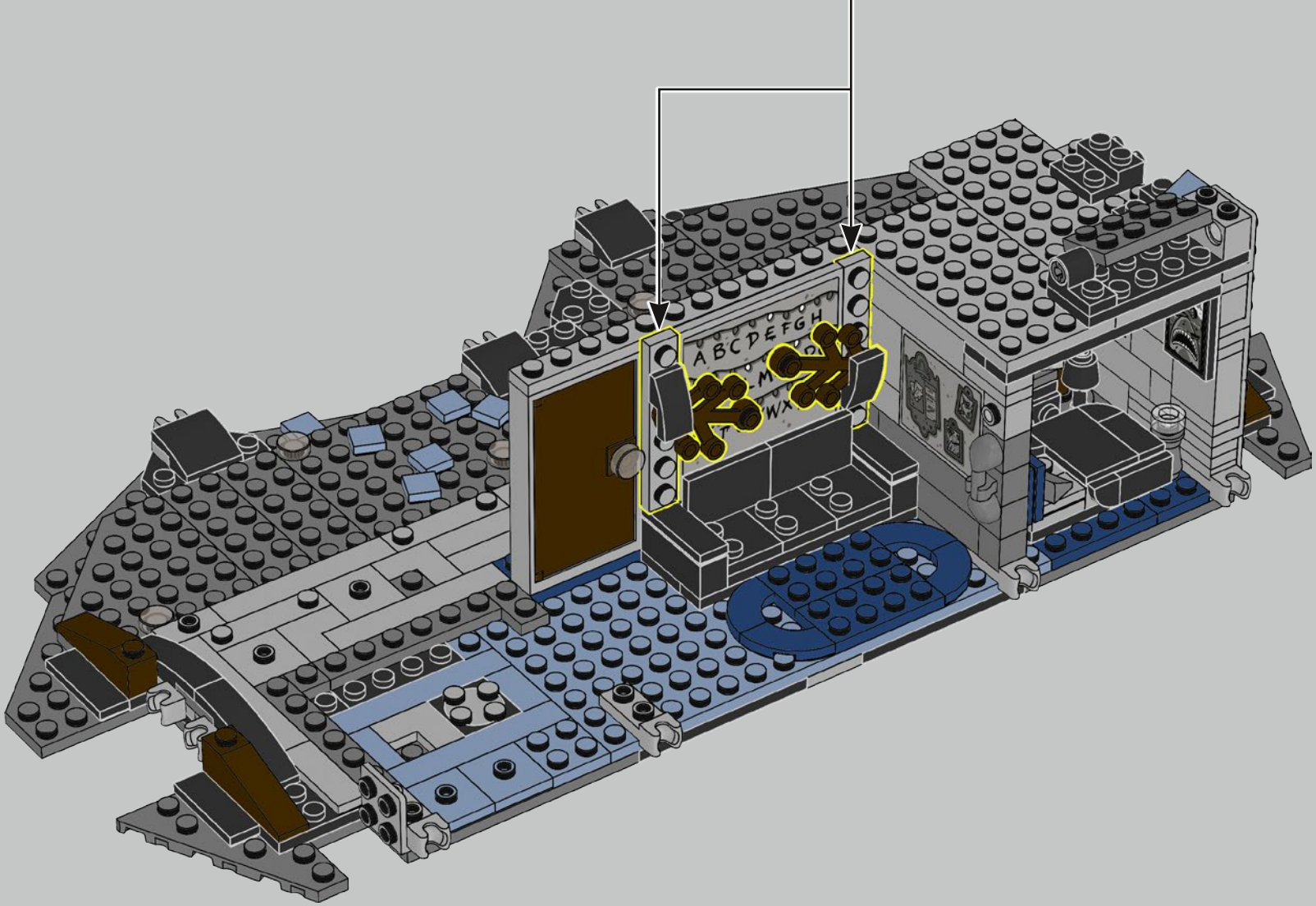
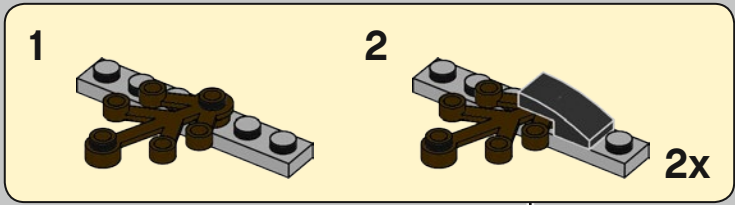

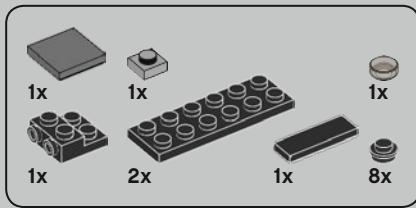

189

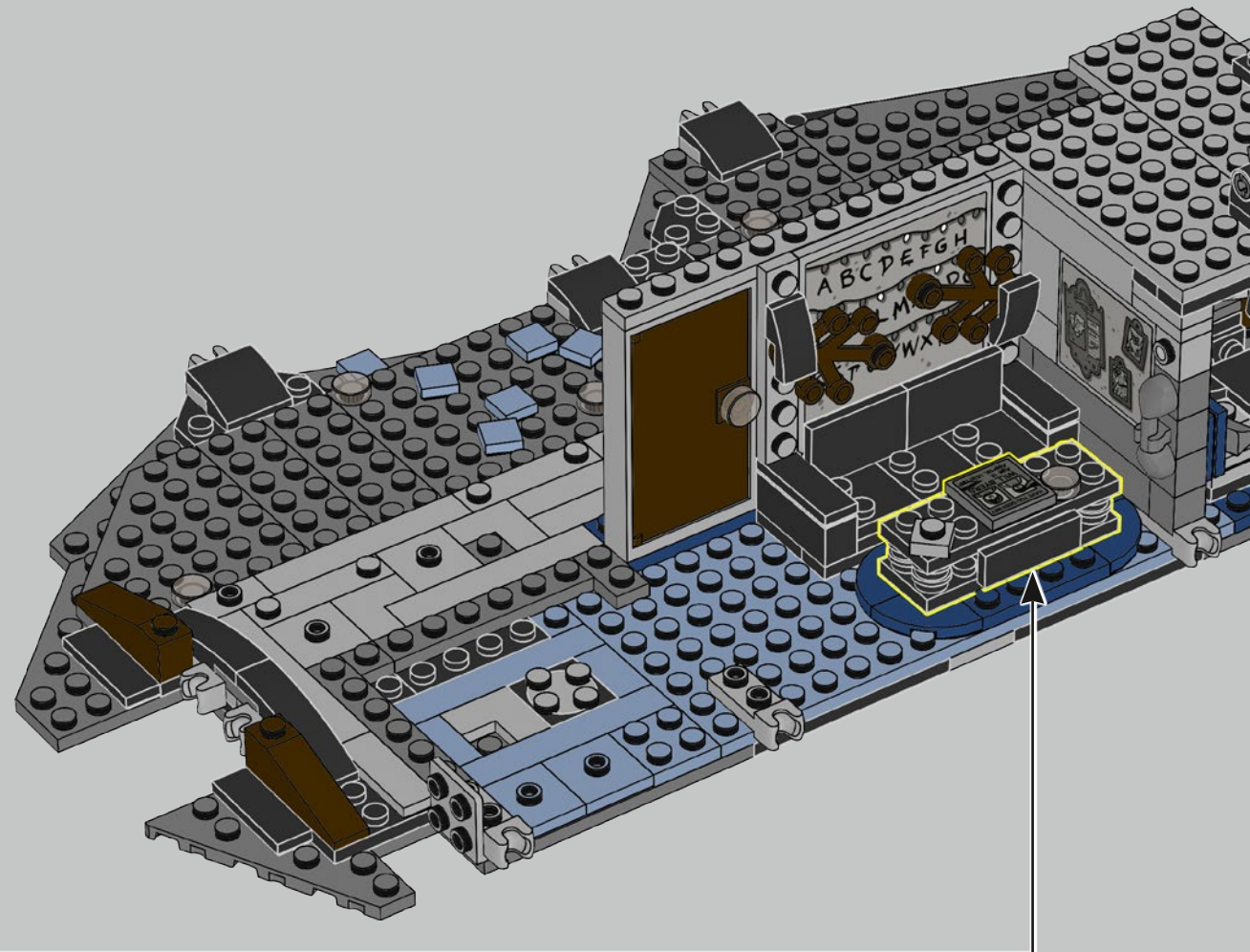
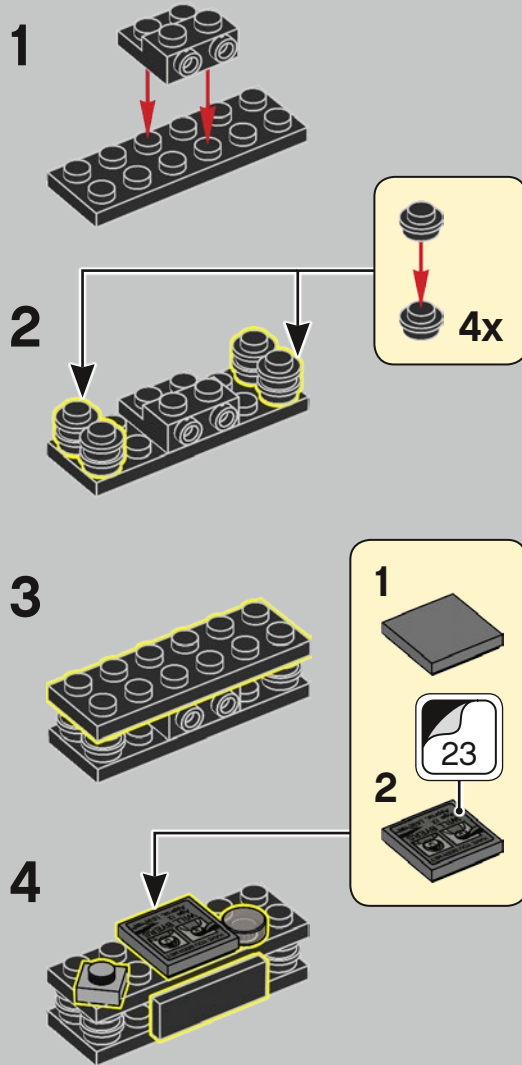

8

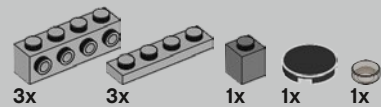

190

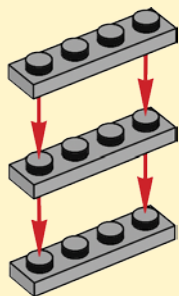
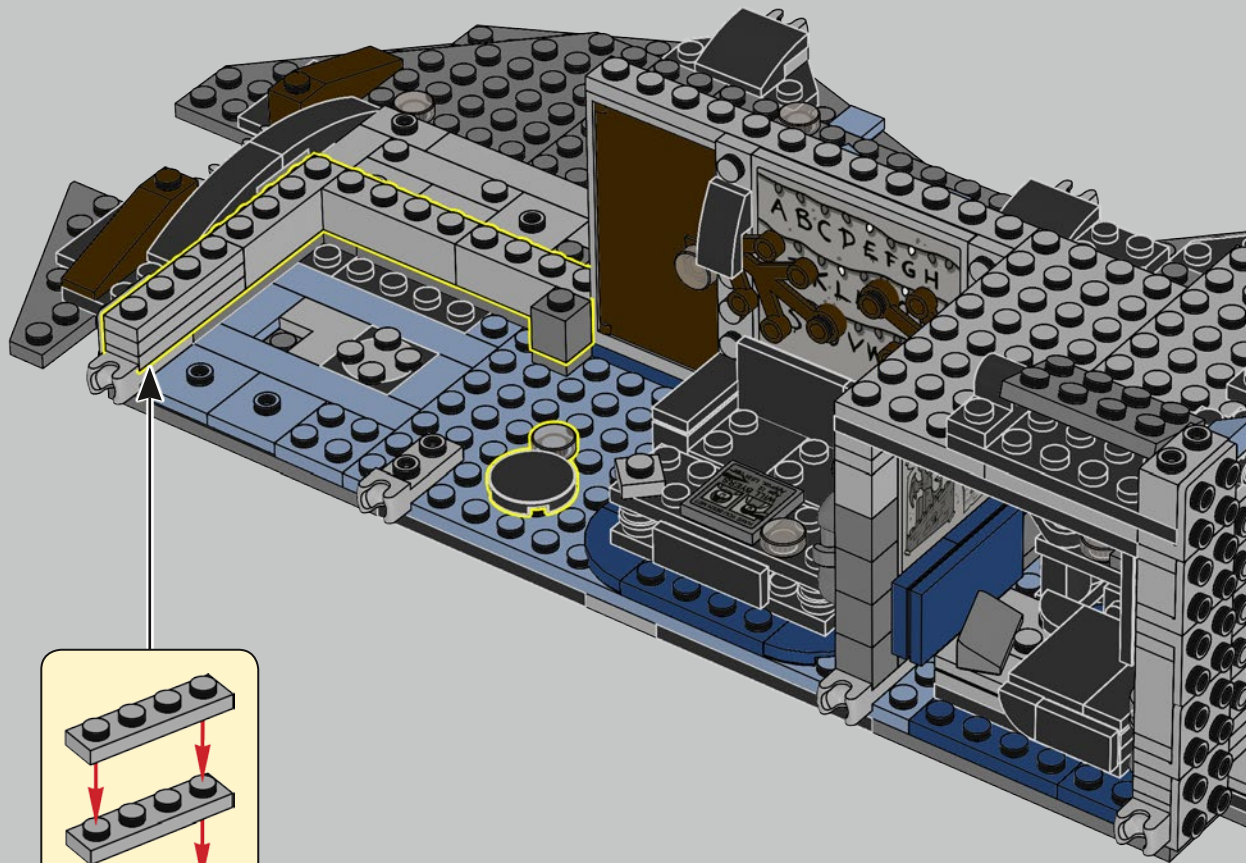

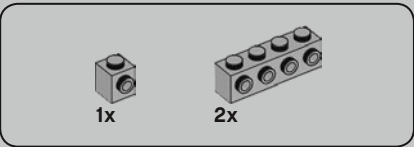

191

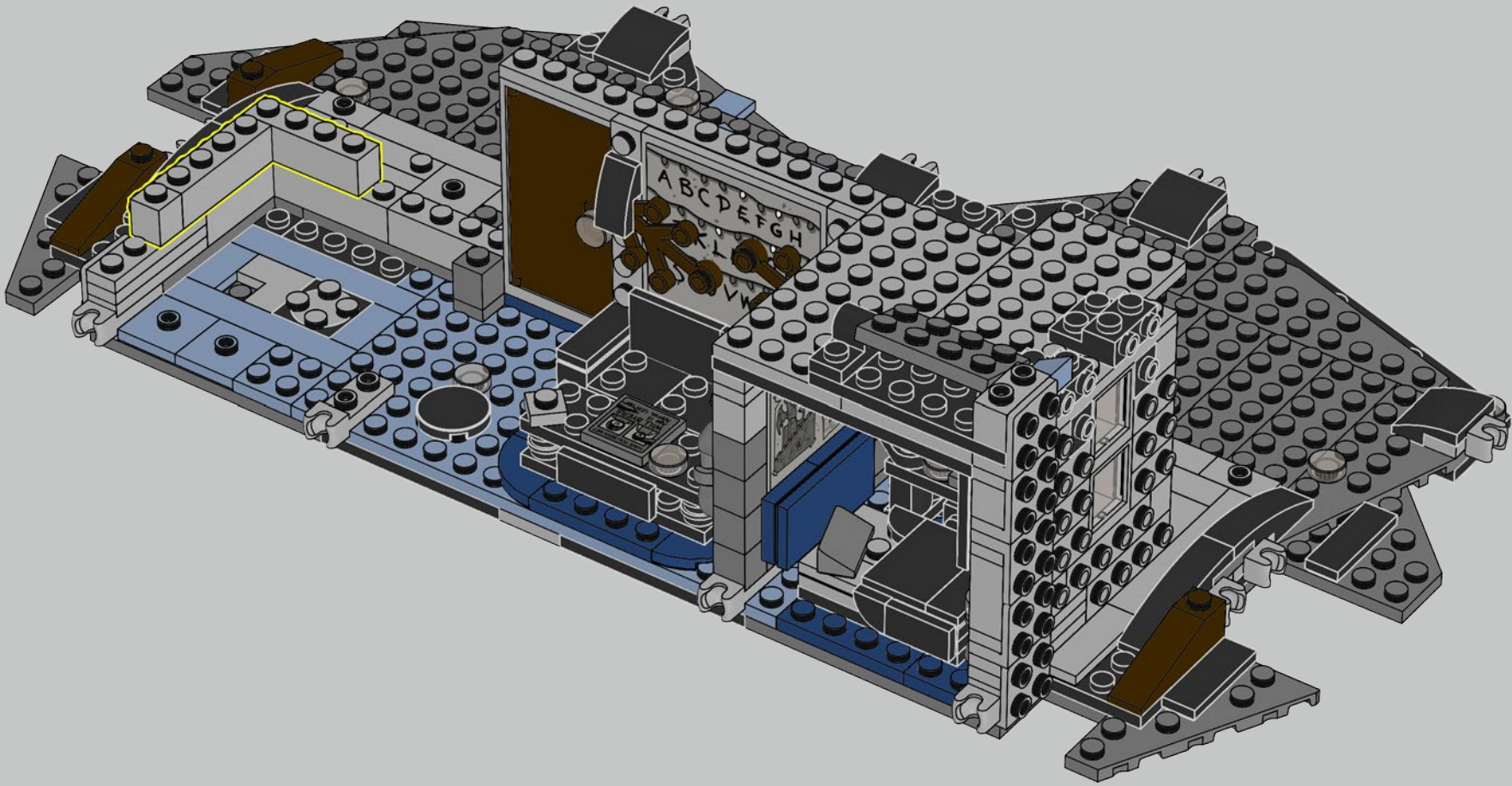

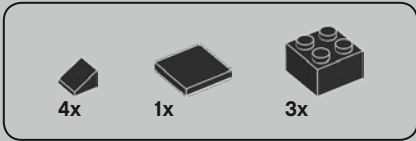

192

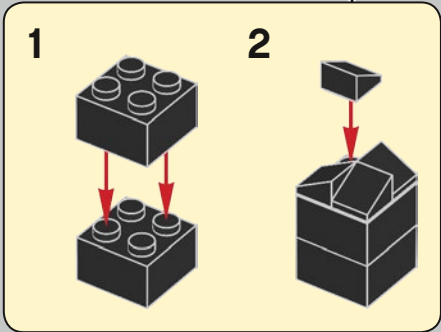
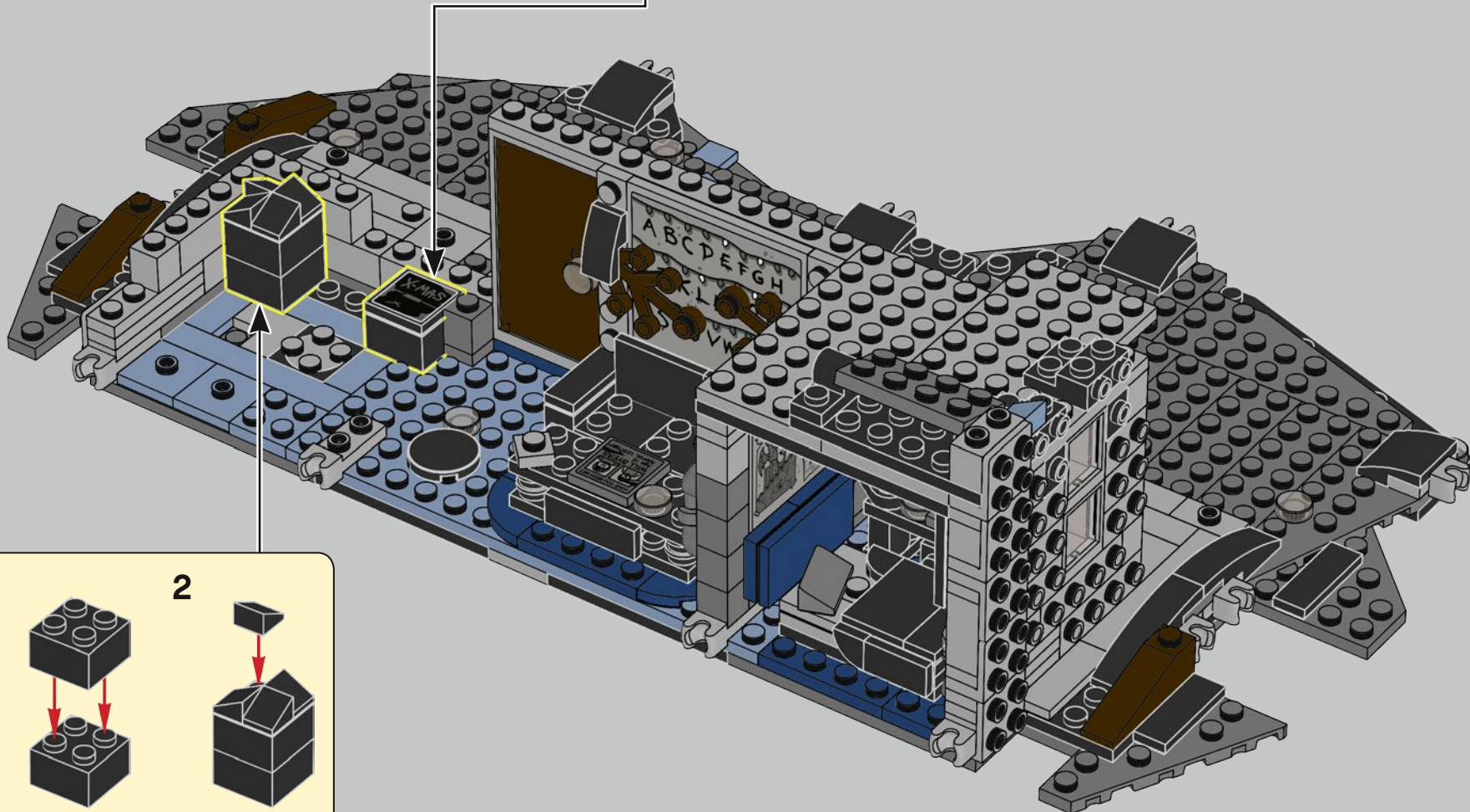
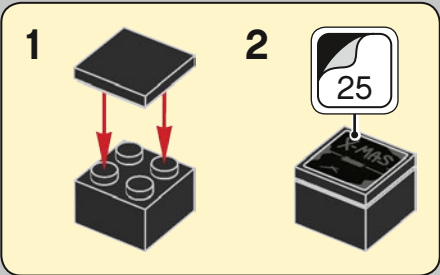

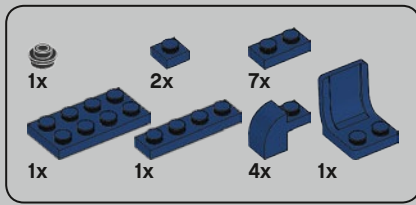

193

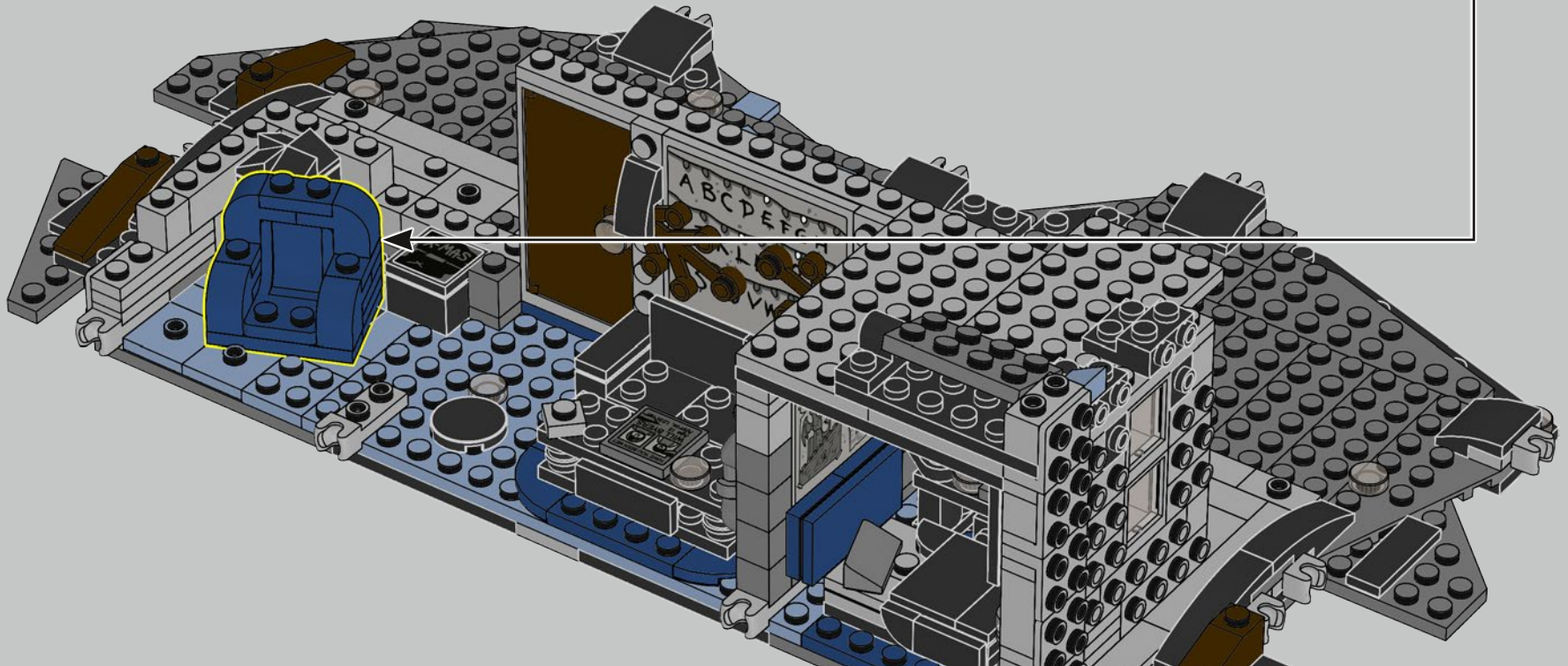
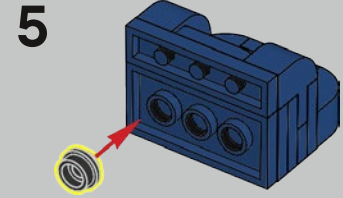
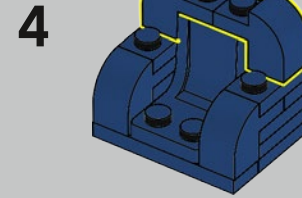
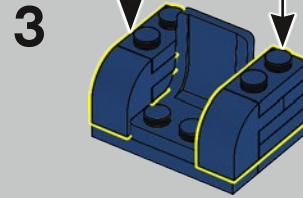
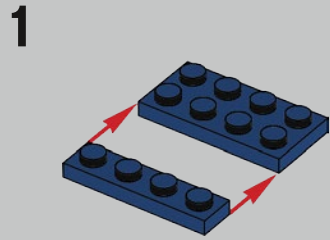
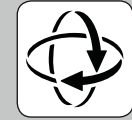
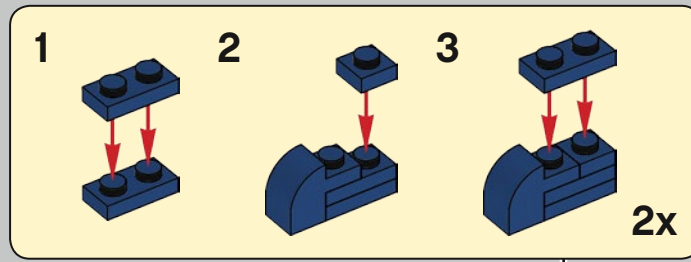

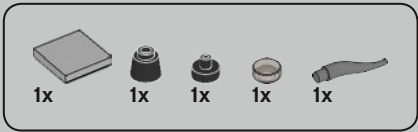

194

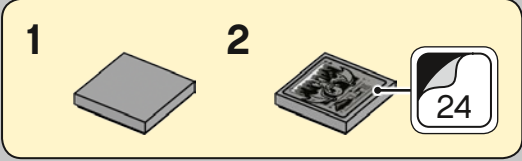
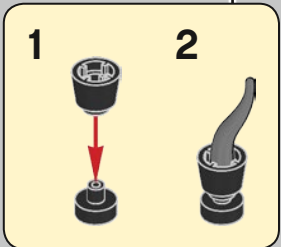
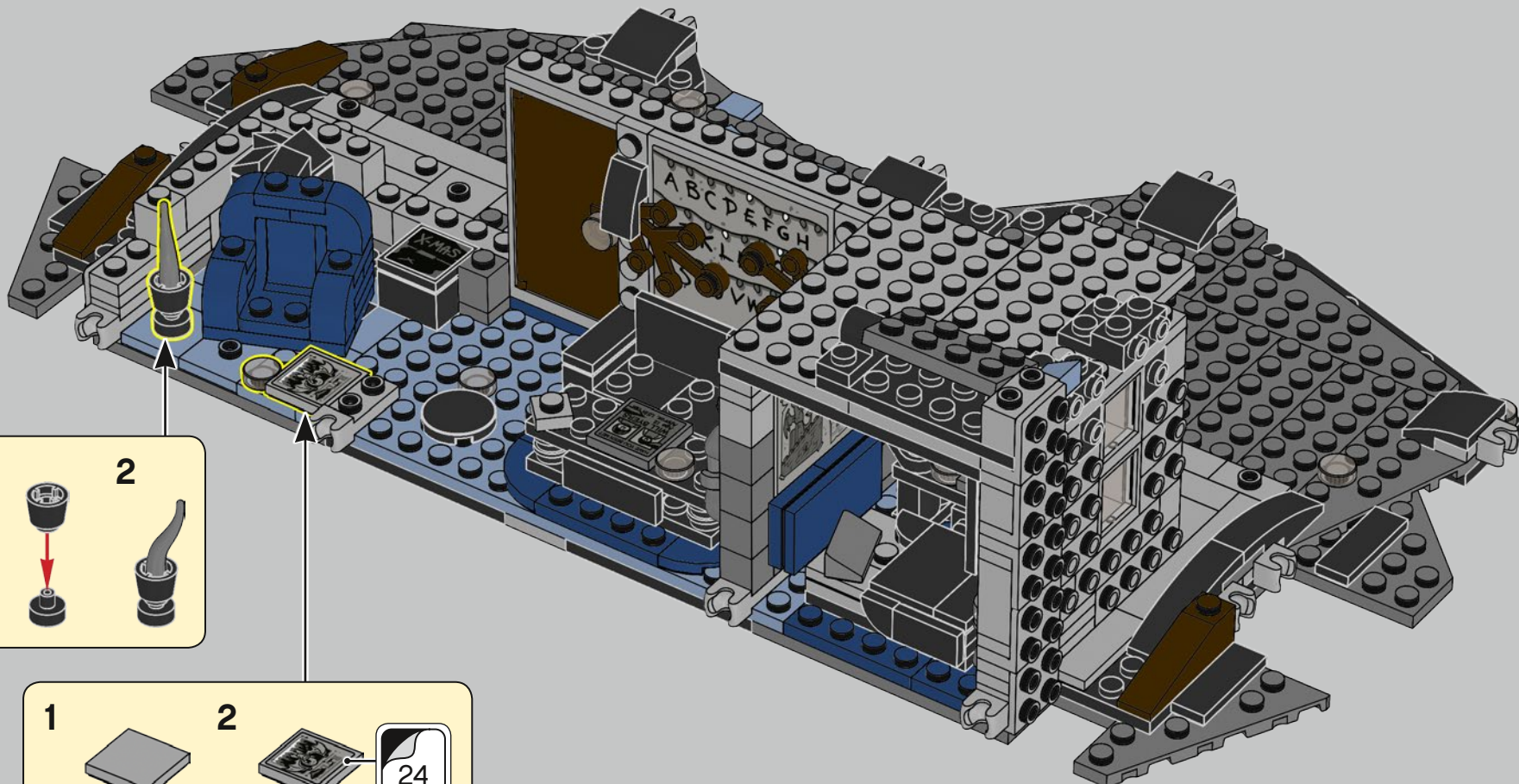

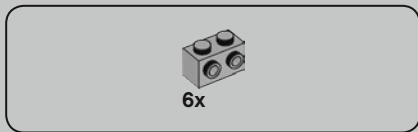

195

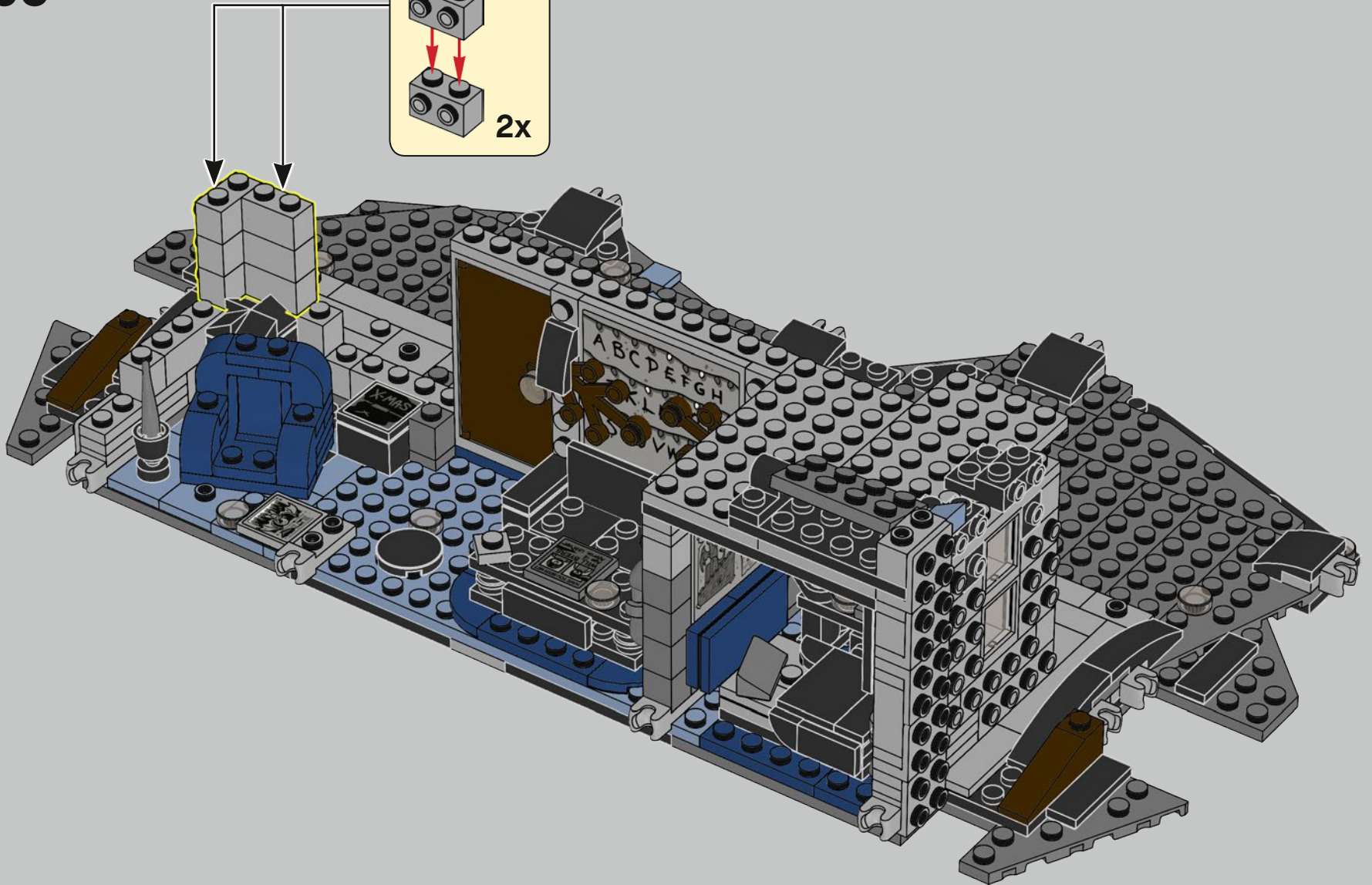
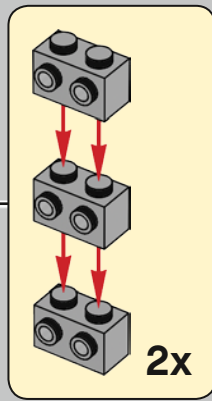

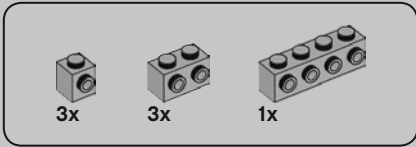

196

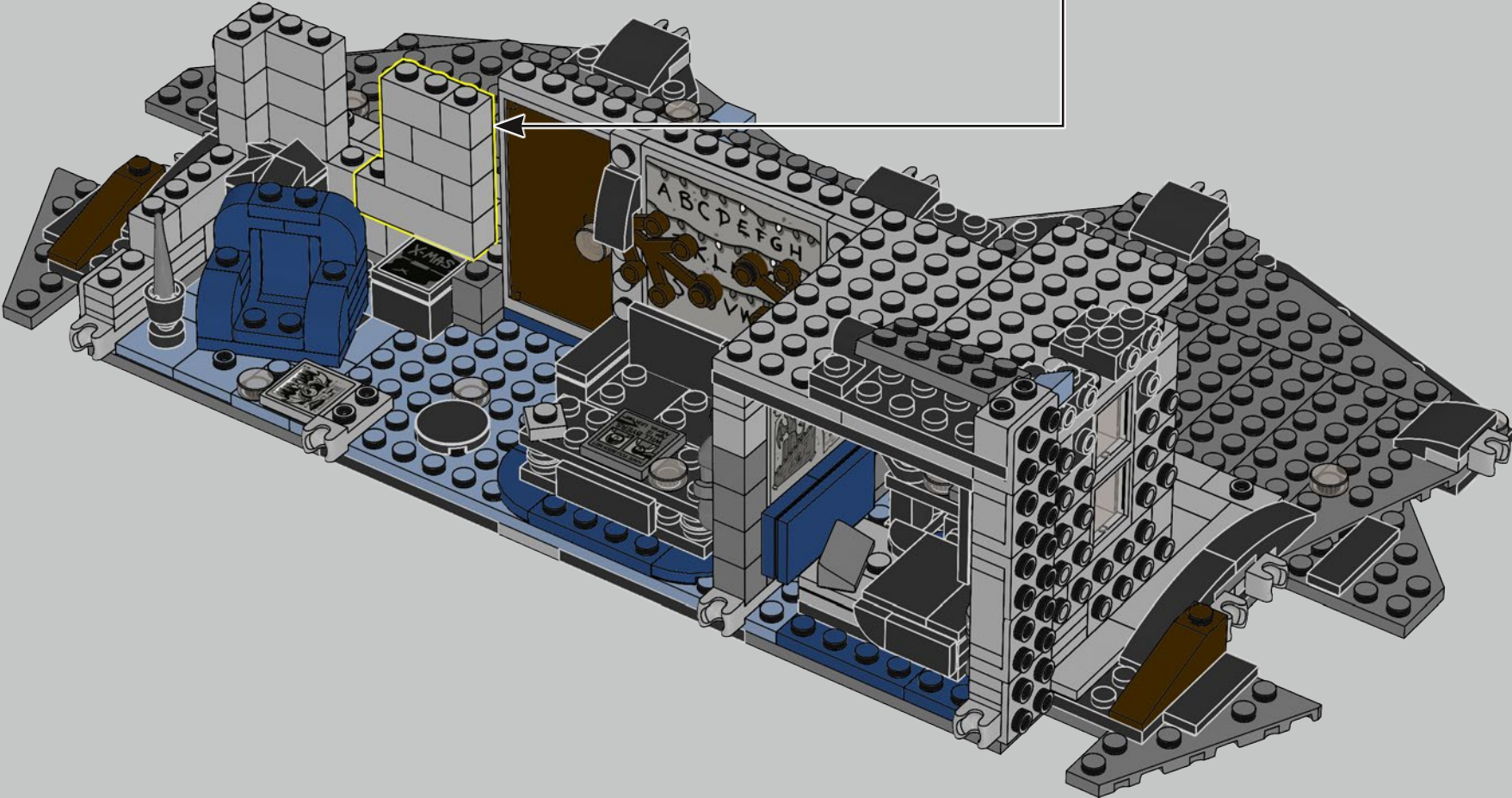
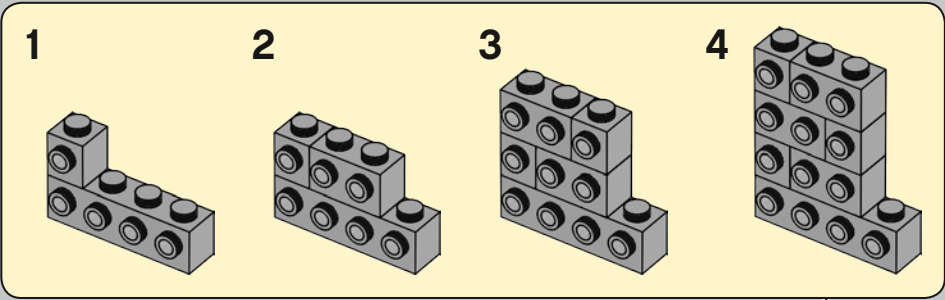

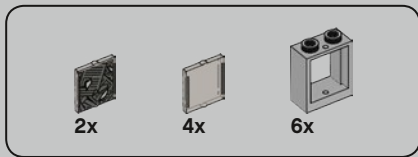

197

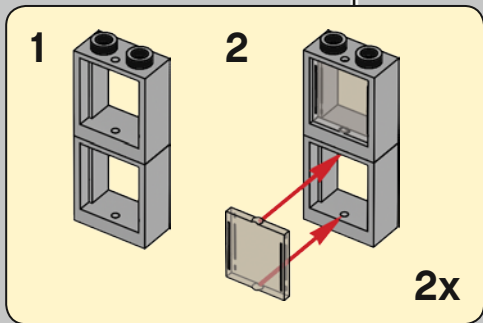
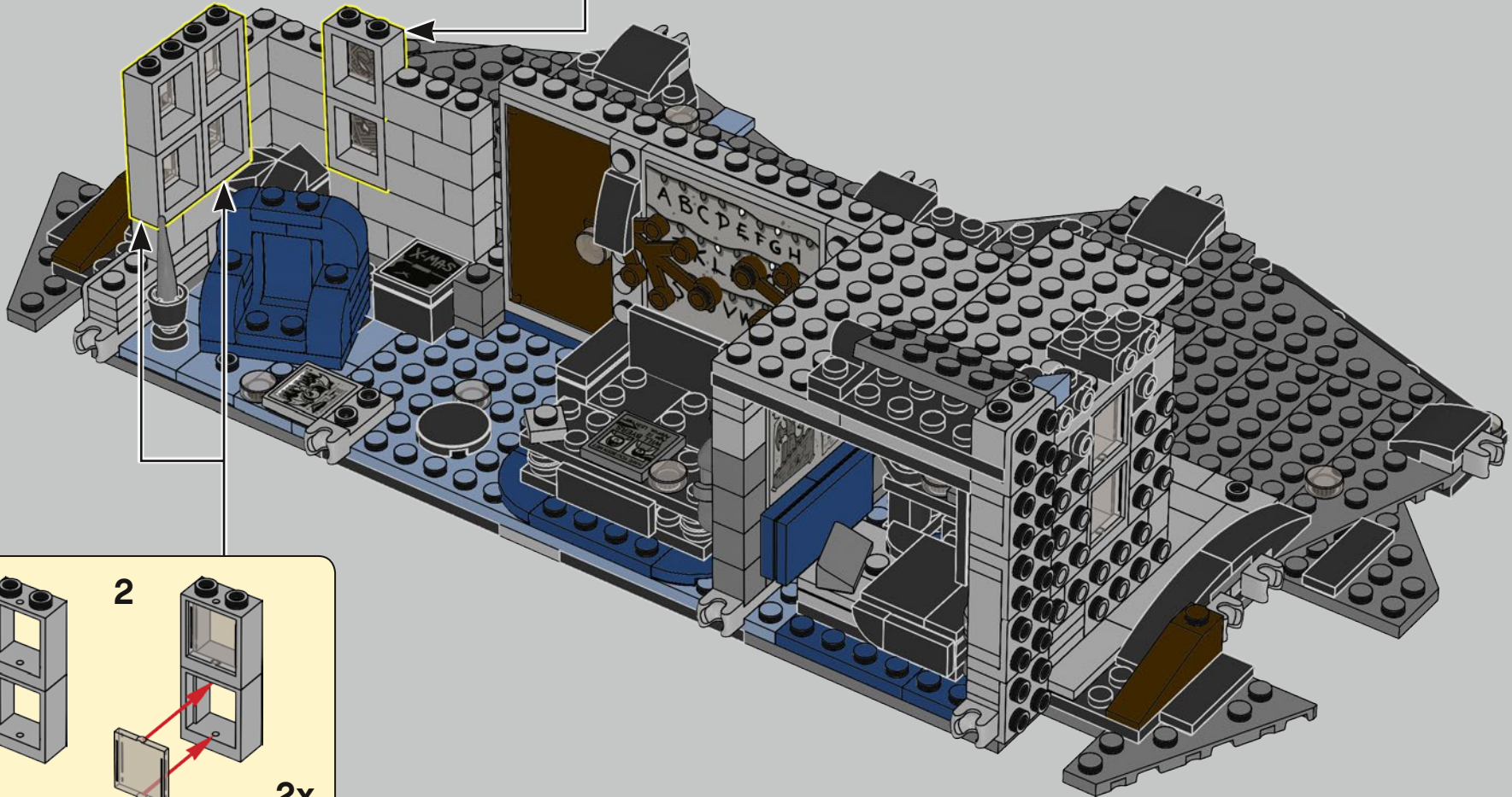
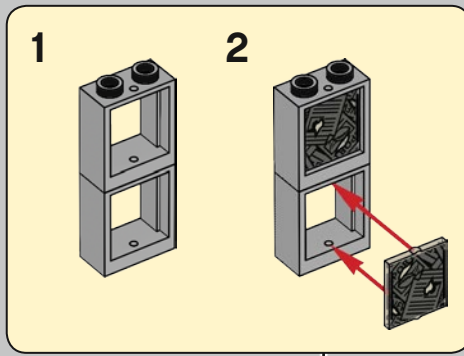

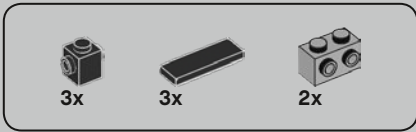

198

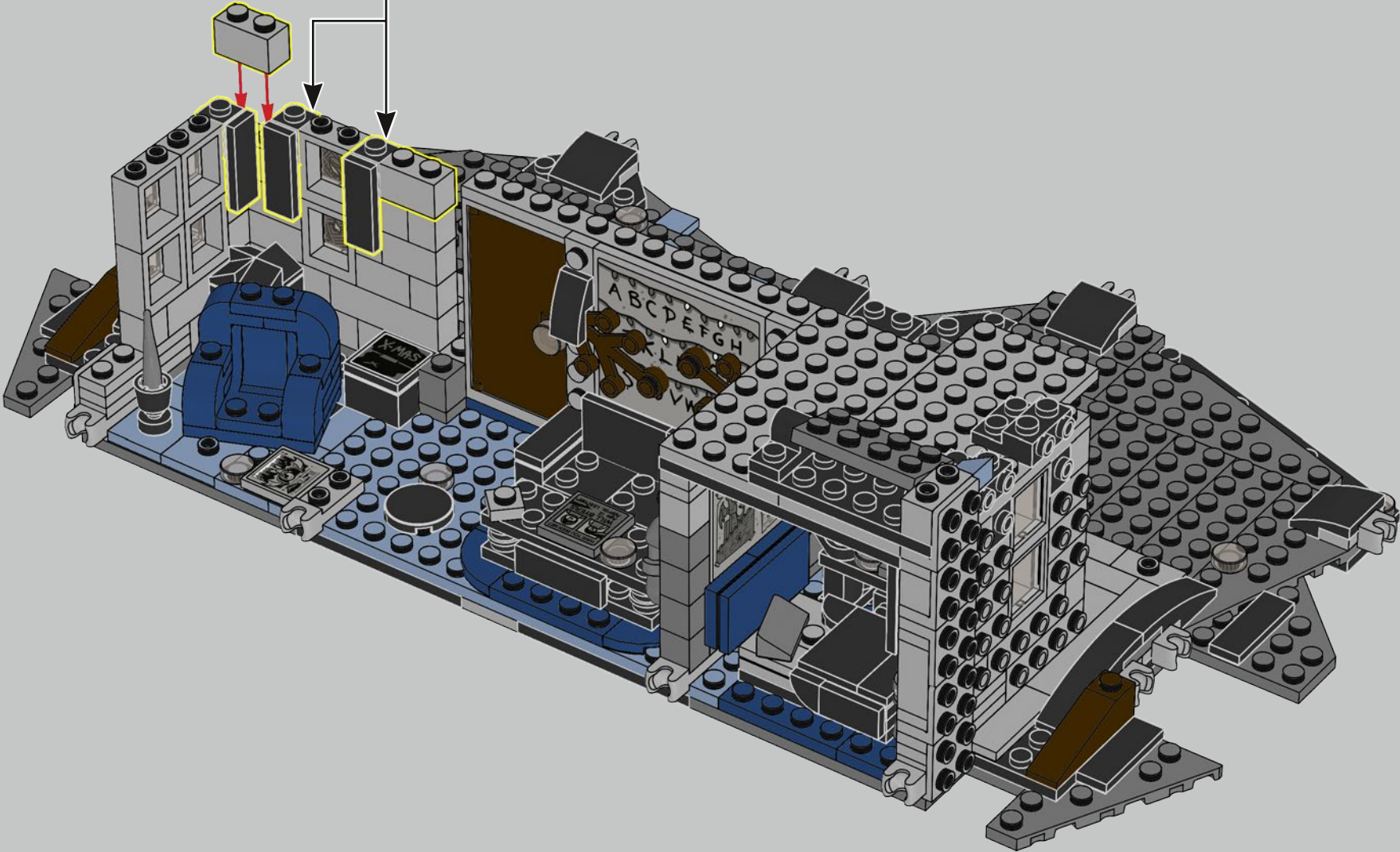
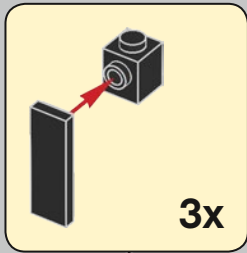

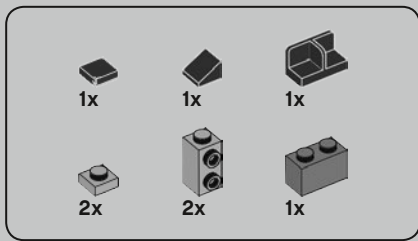

199

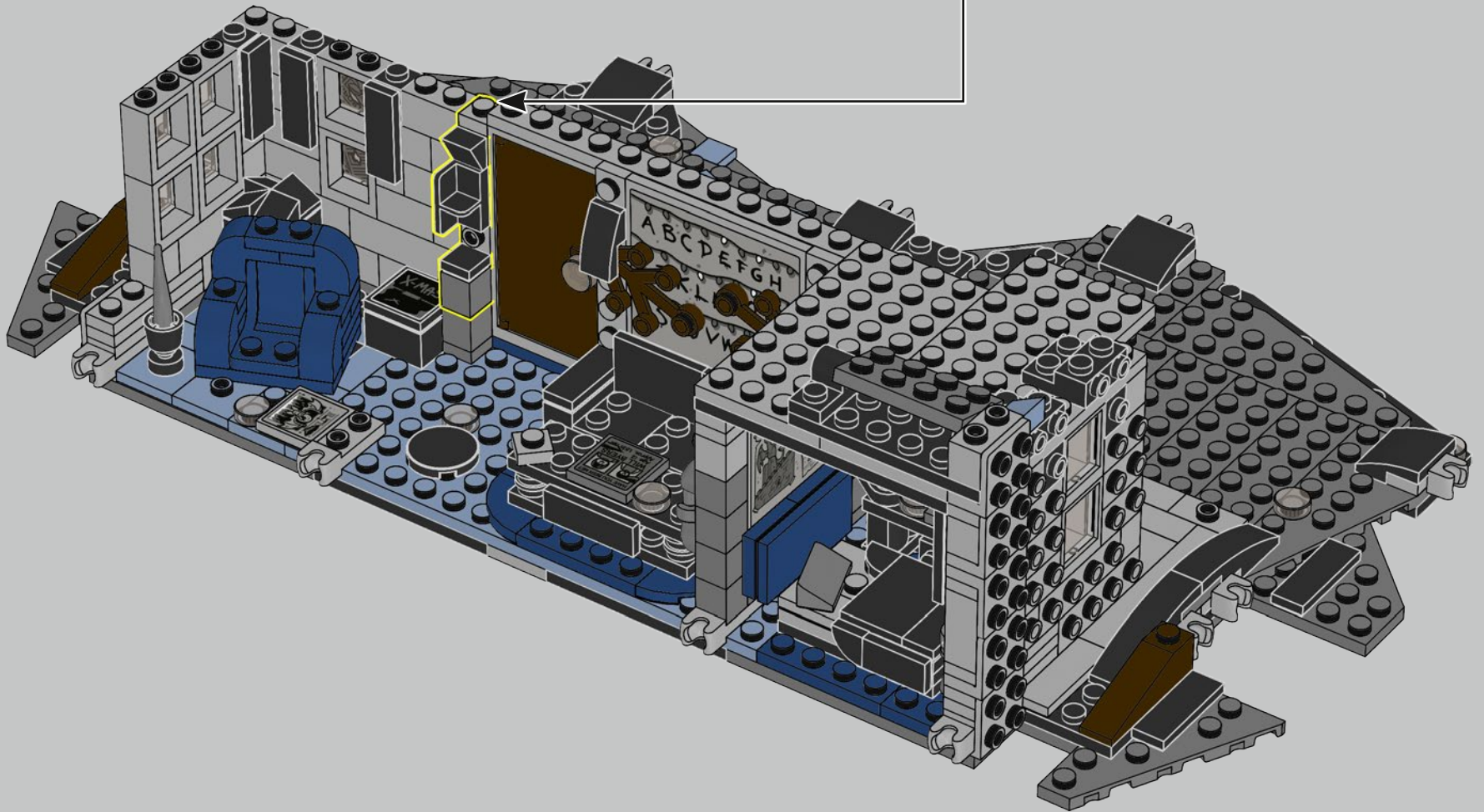
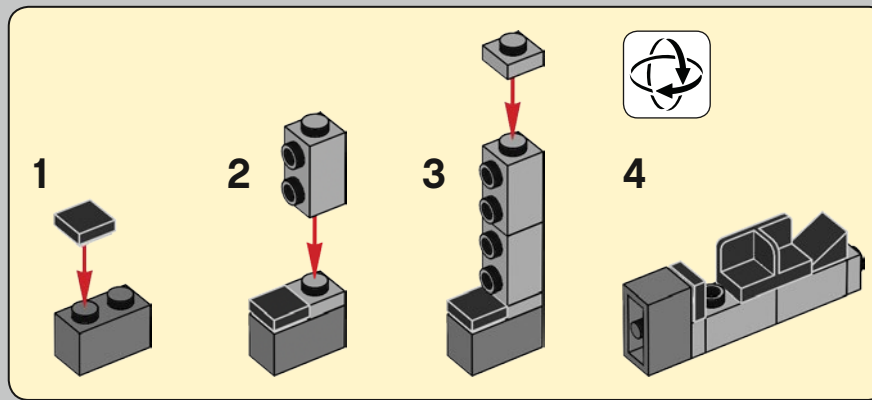

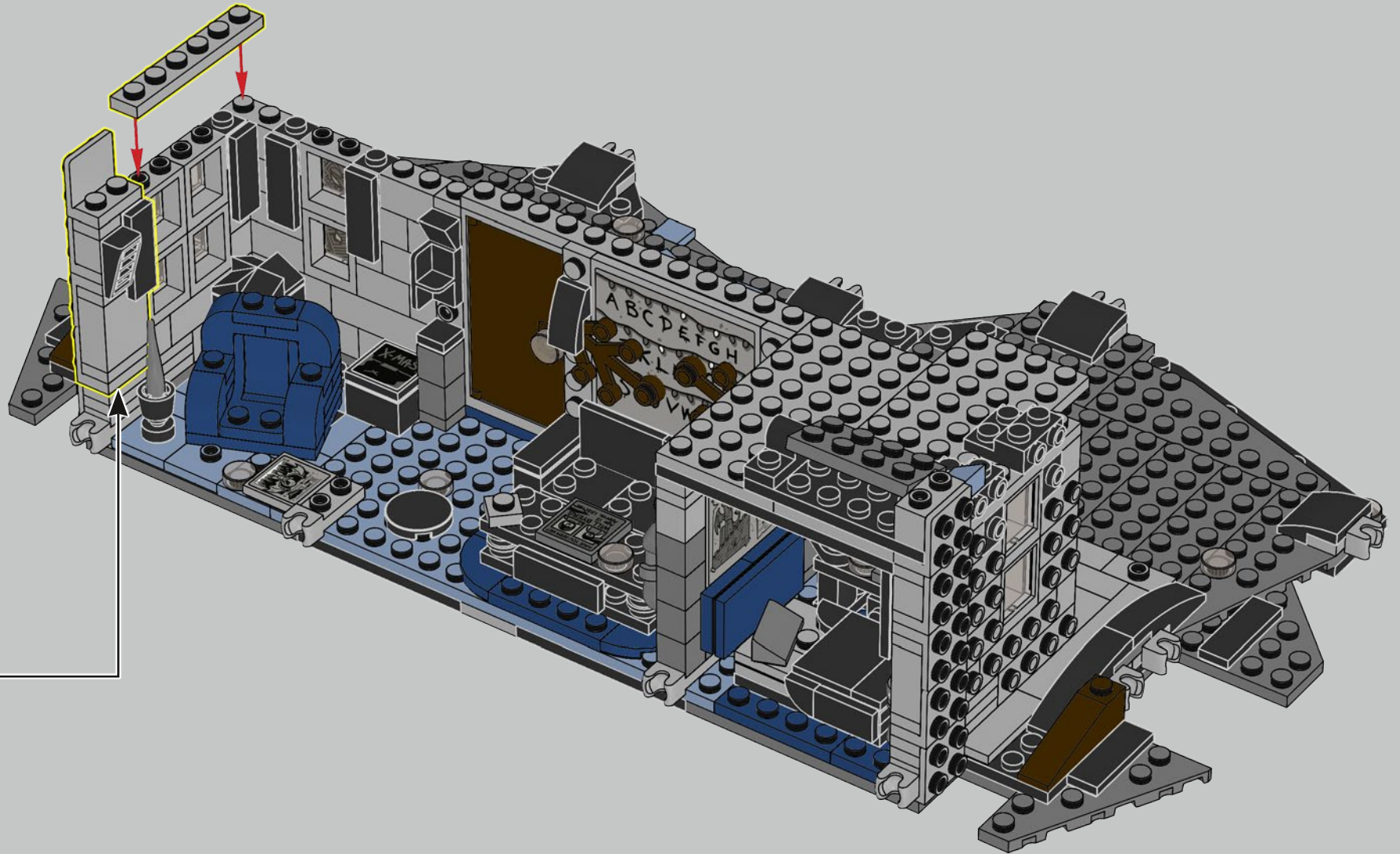

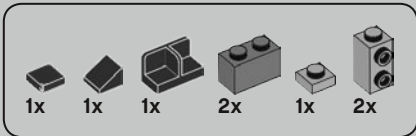

201

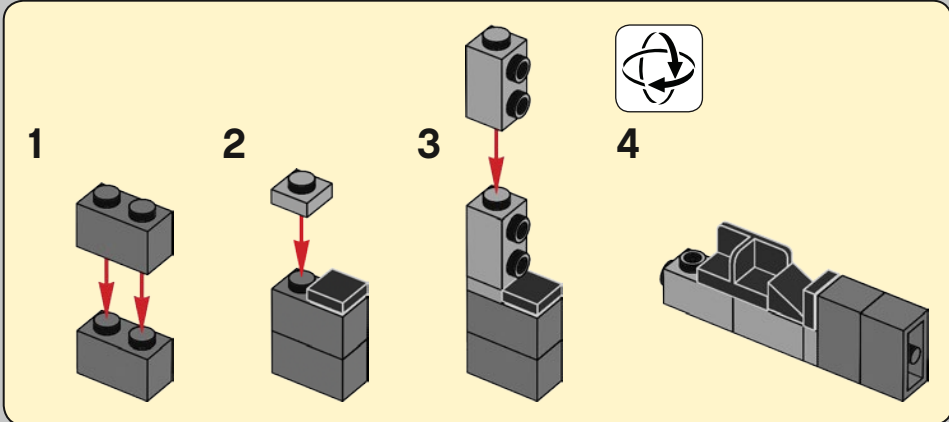
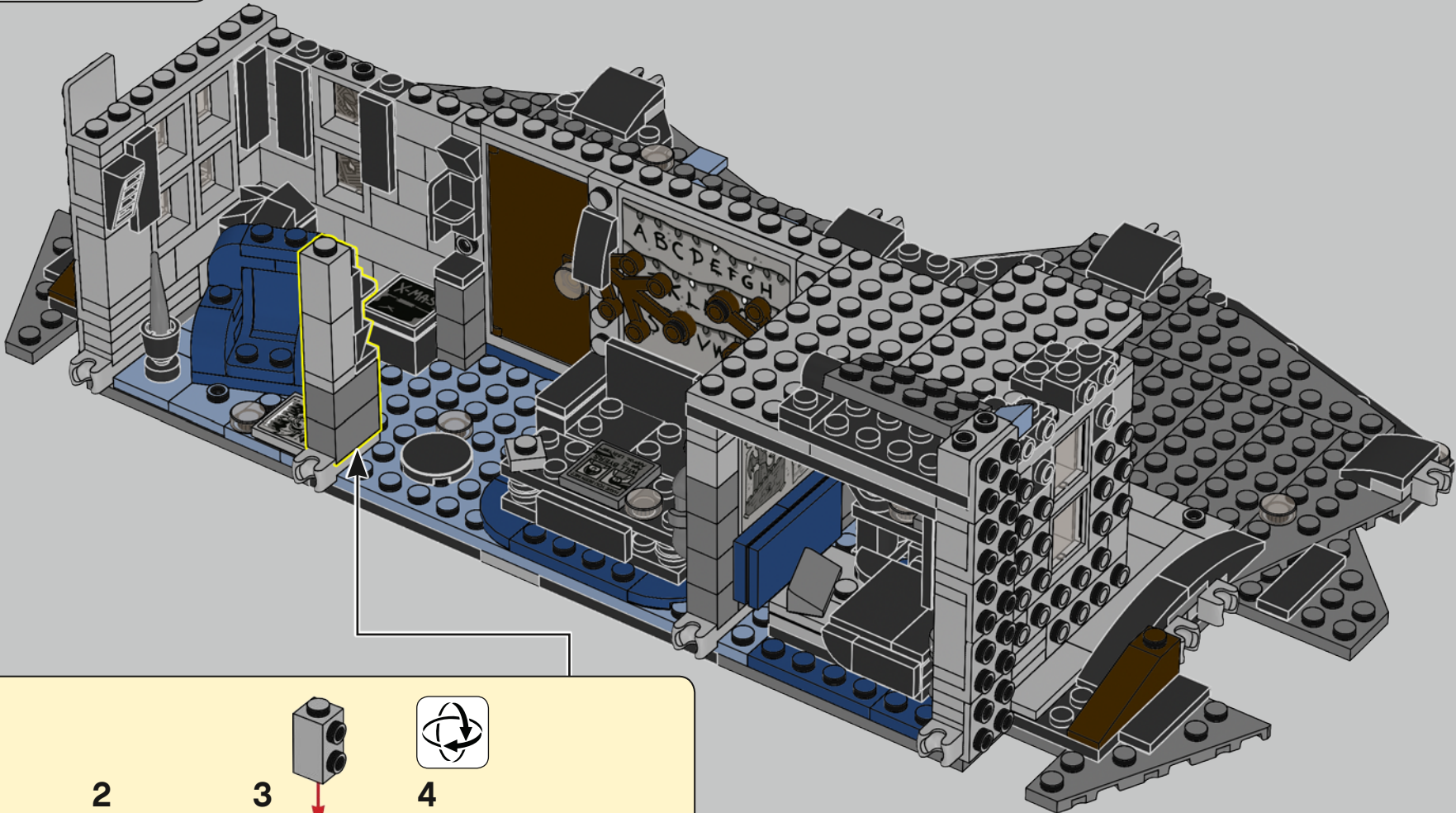

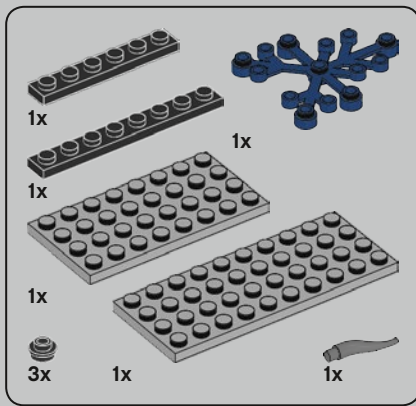

202

1

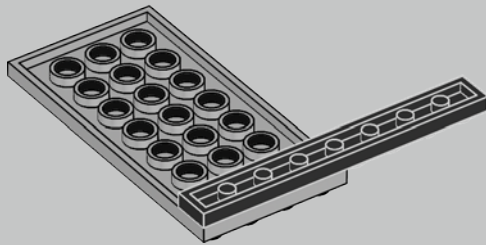

2

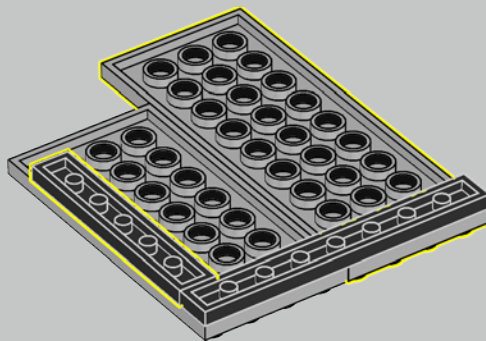

3

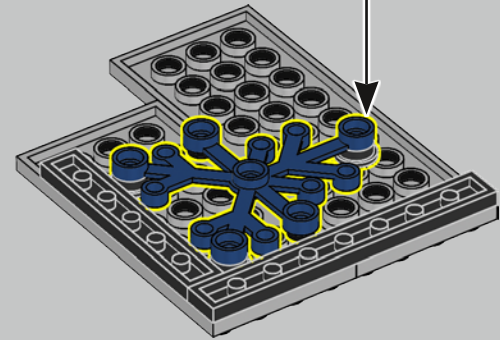

4

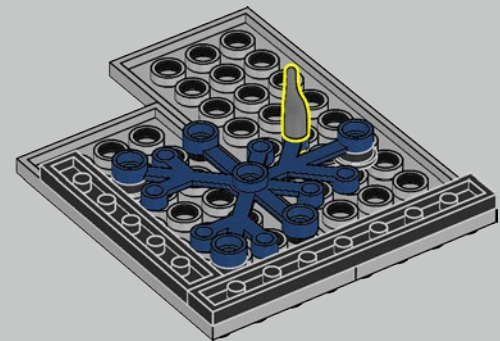

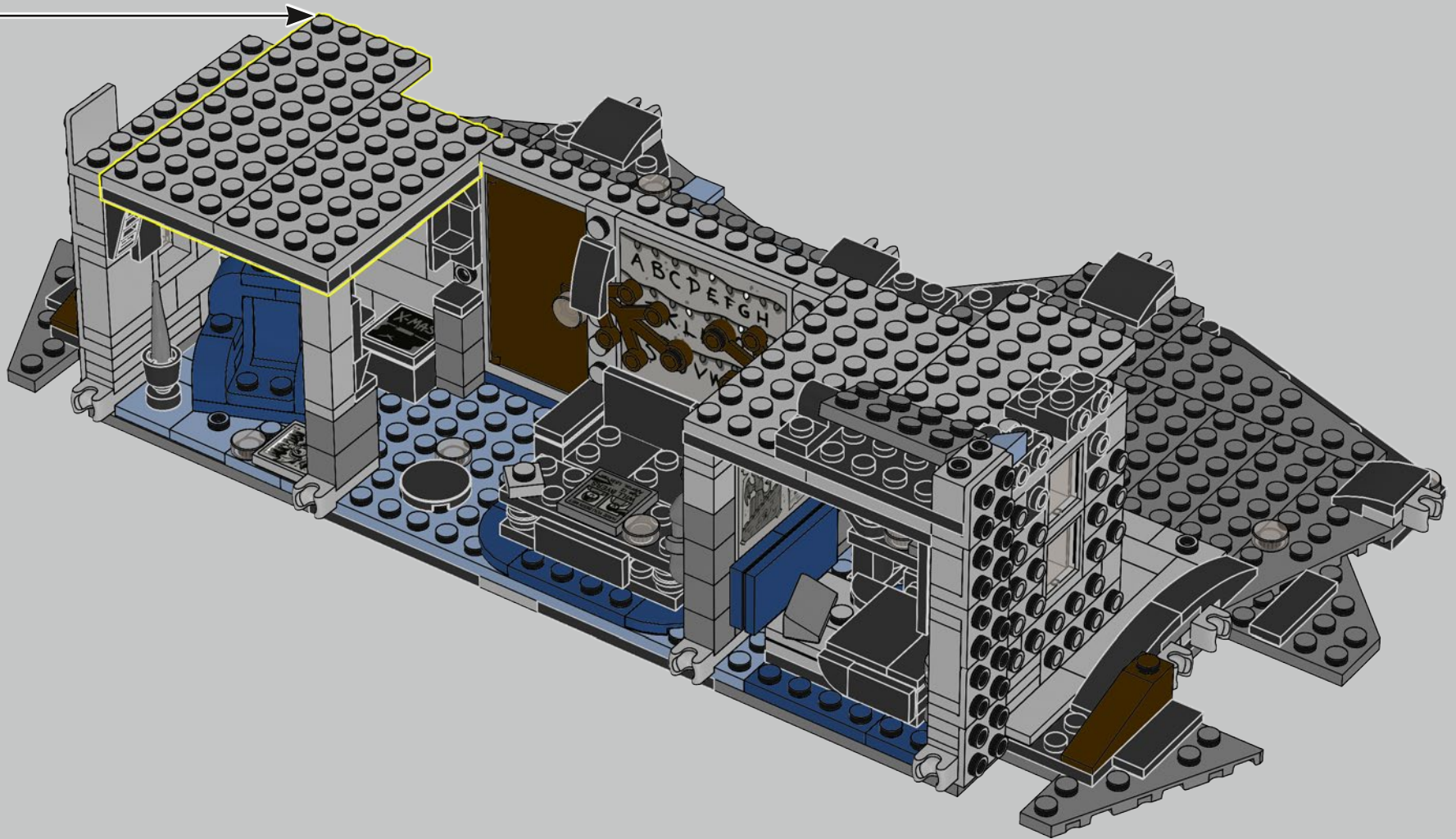



2x



1x

203

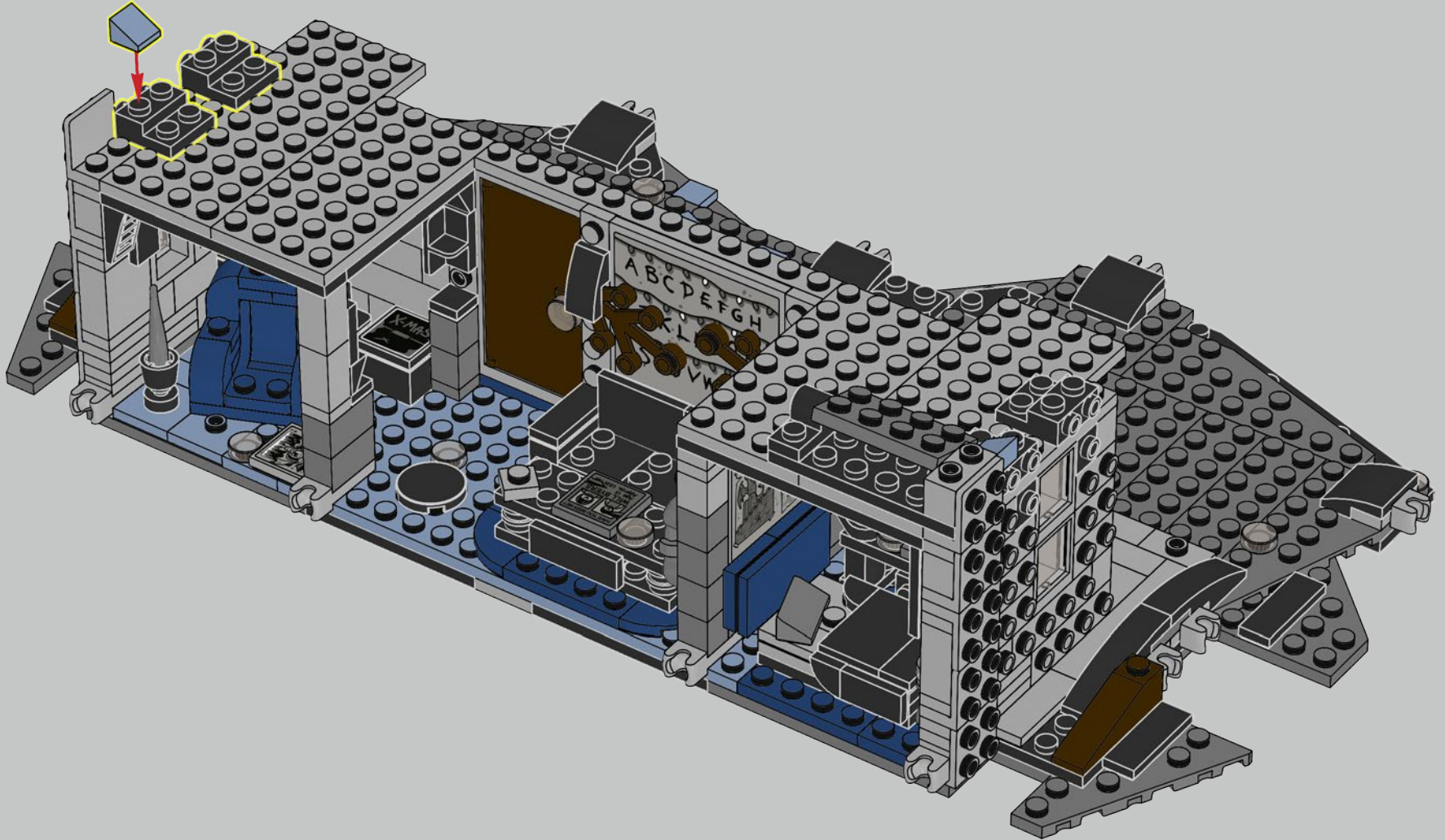

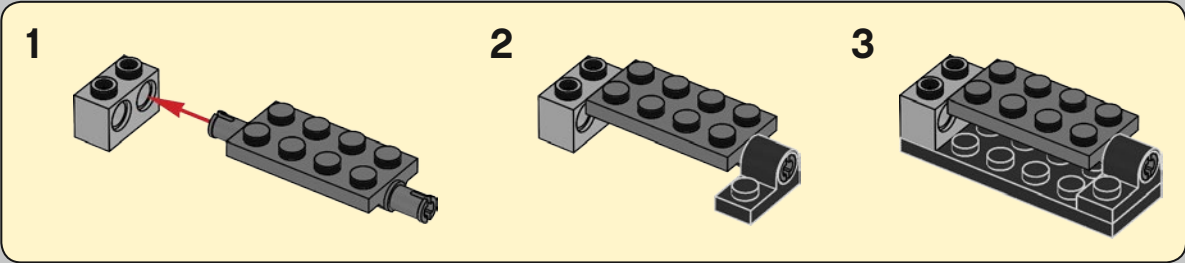
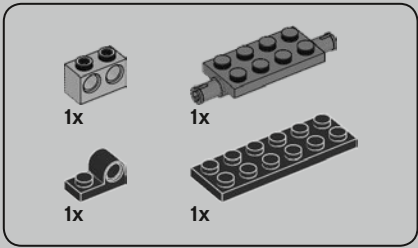

204

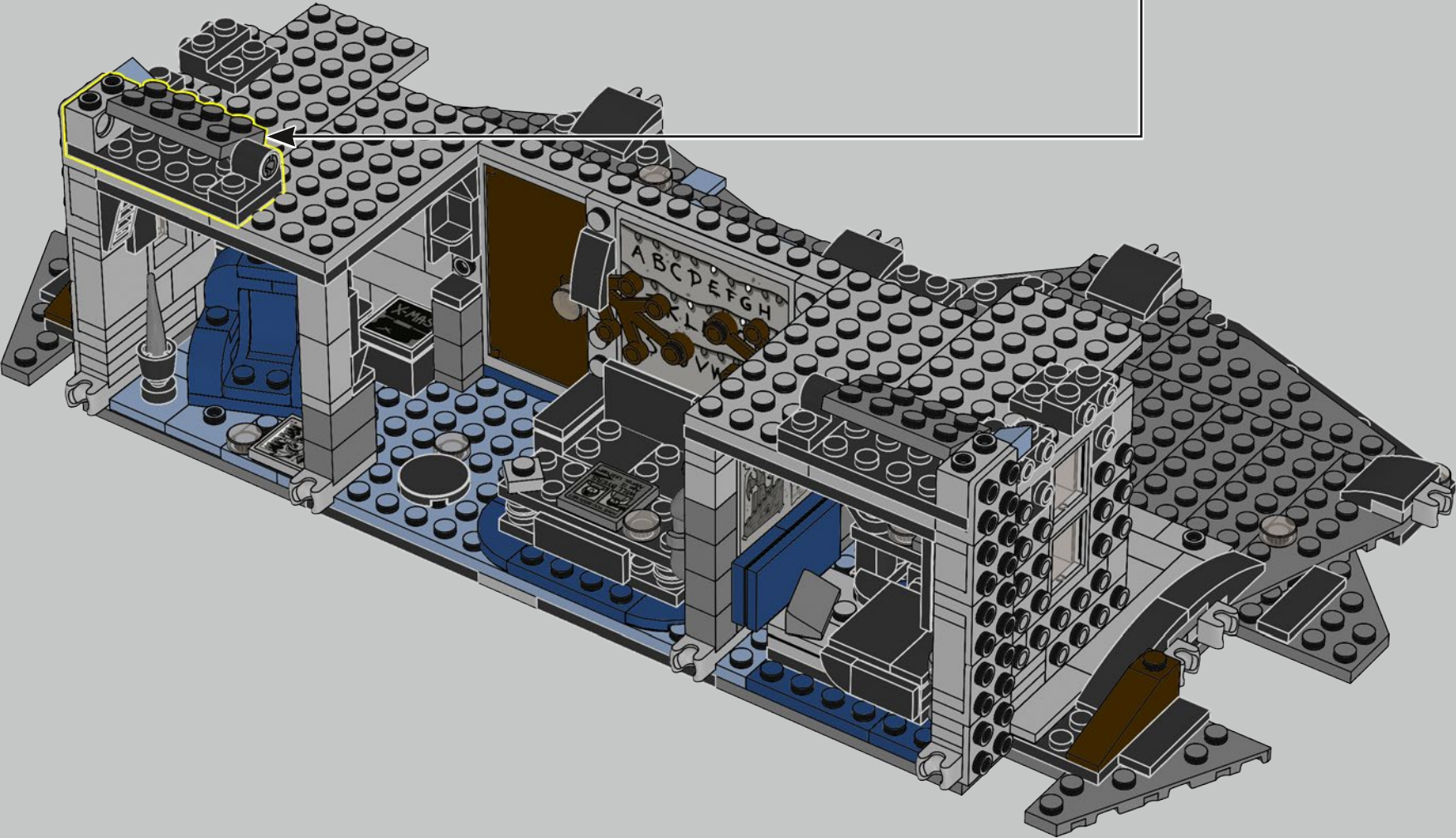

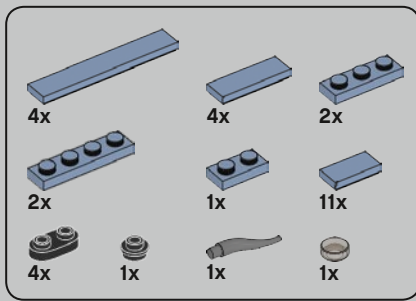

205

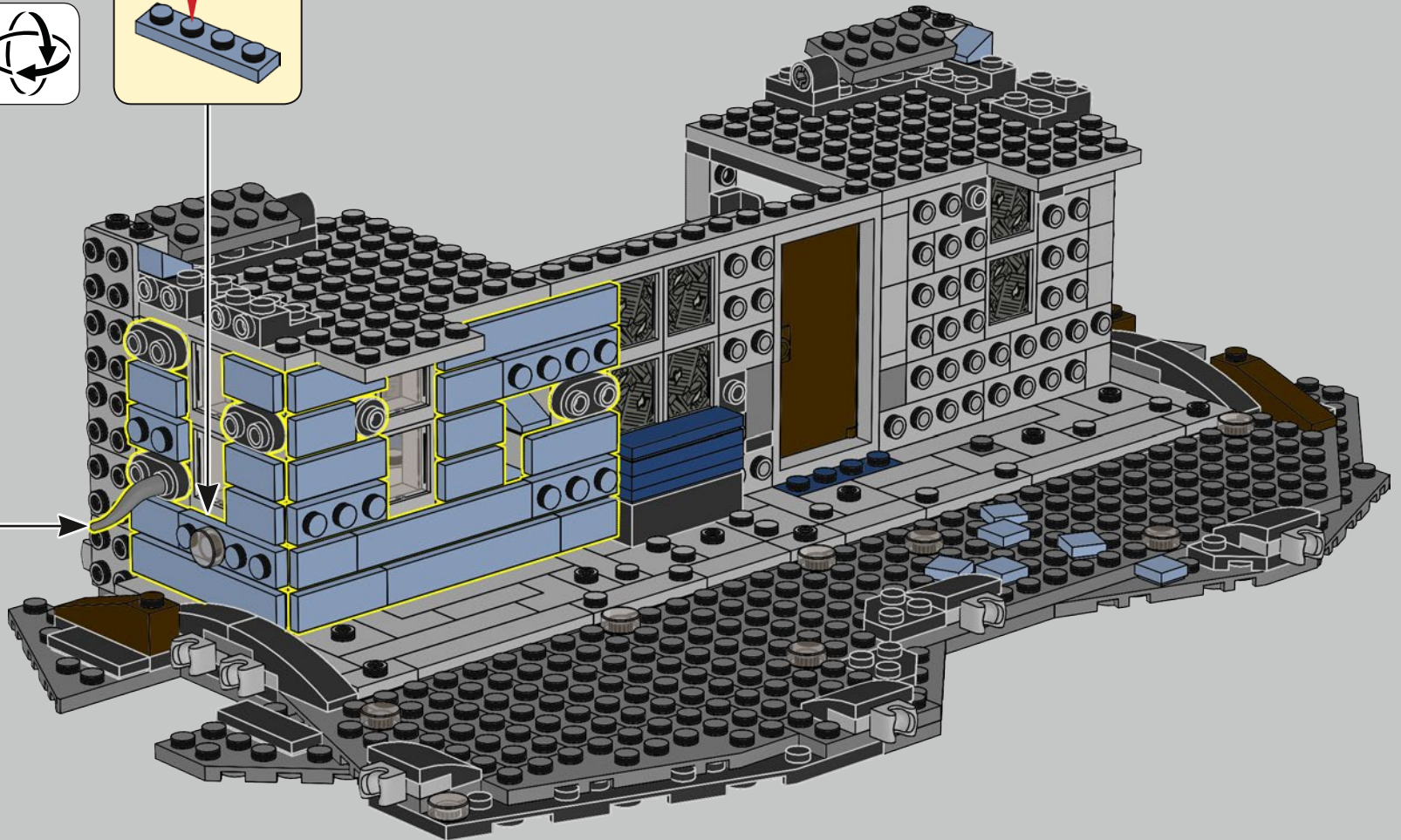
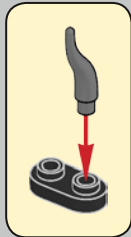
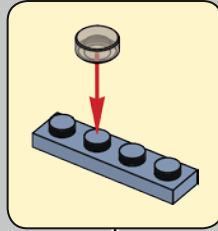

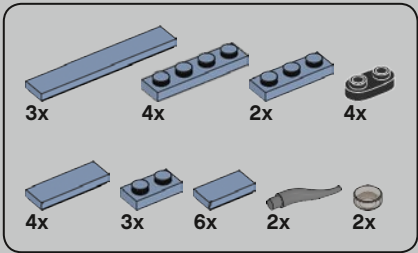

206

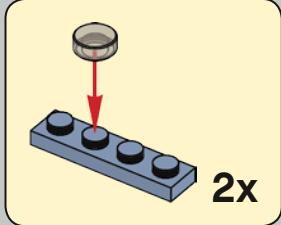
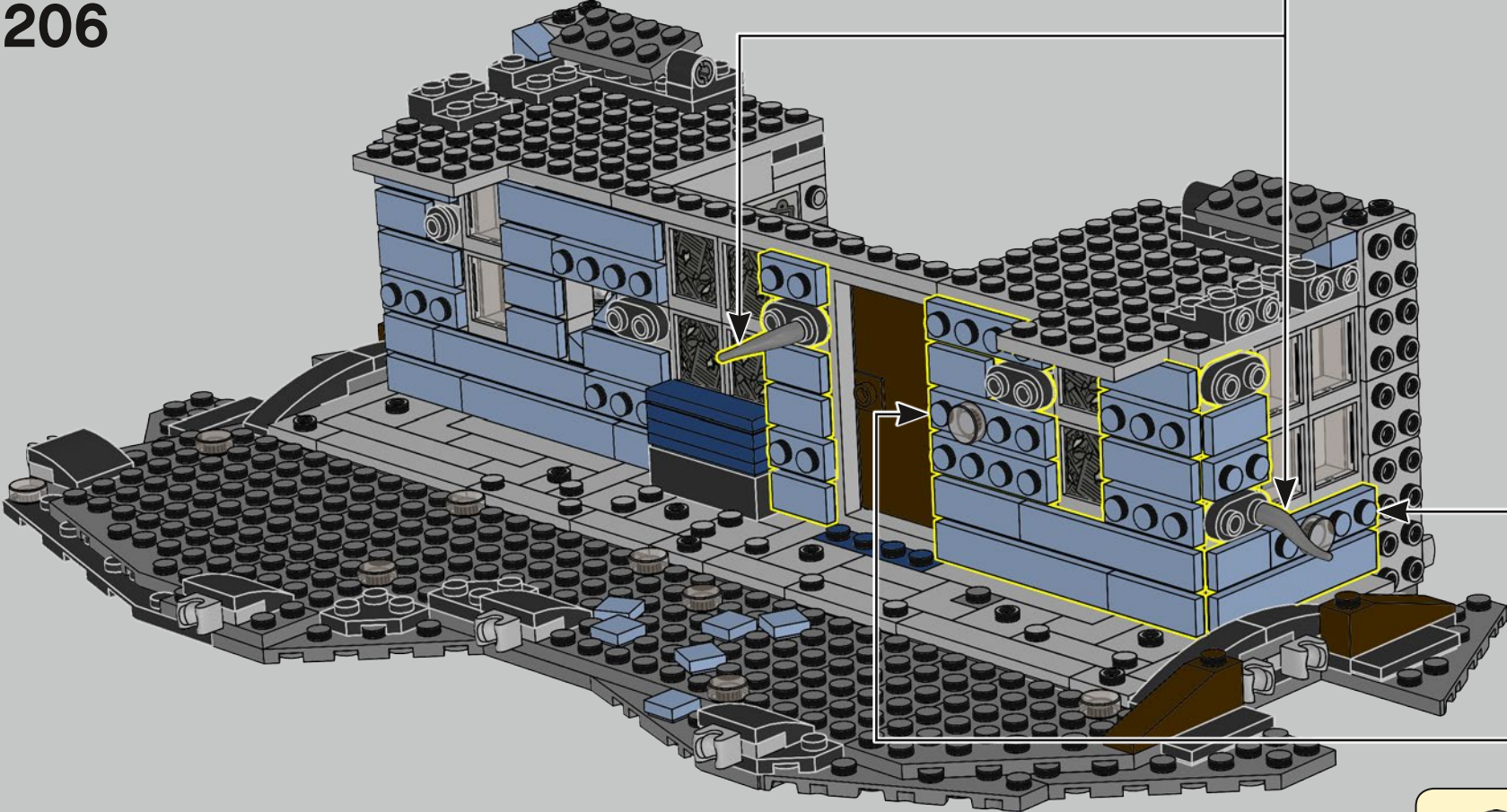
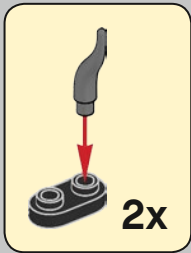

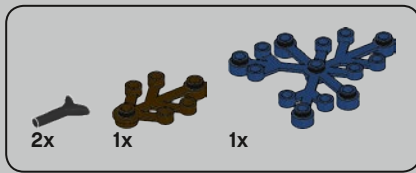

207

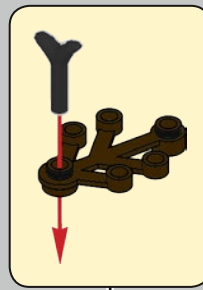
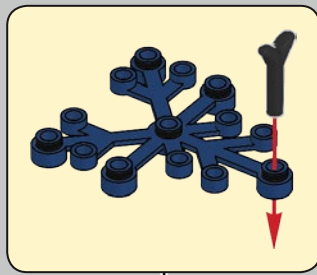

The Byers' home, with the porch swing in the foreground, is an homage to *The Evil Dead* (1981).

La maison des Byers, y compris la balancelle sur la galerie, est inspirée du film *L'Opéra de la terreur* (1981).

La casa de los Byers, con el columpio del porche en primer plano, es un homenaje a *El Despertar del Diablo* (1981).

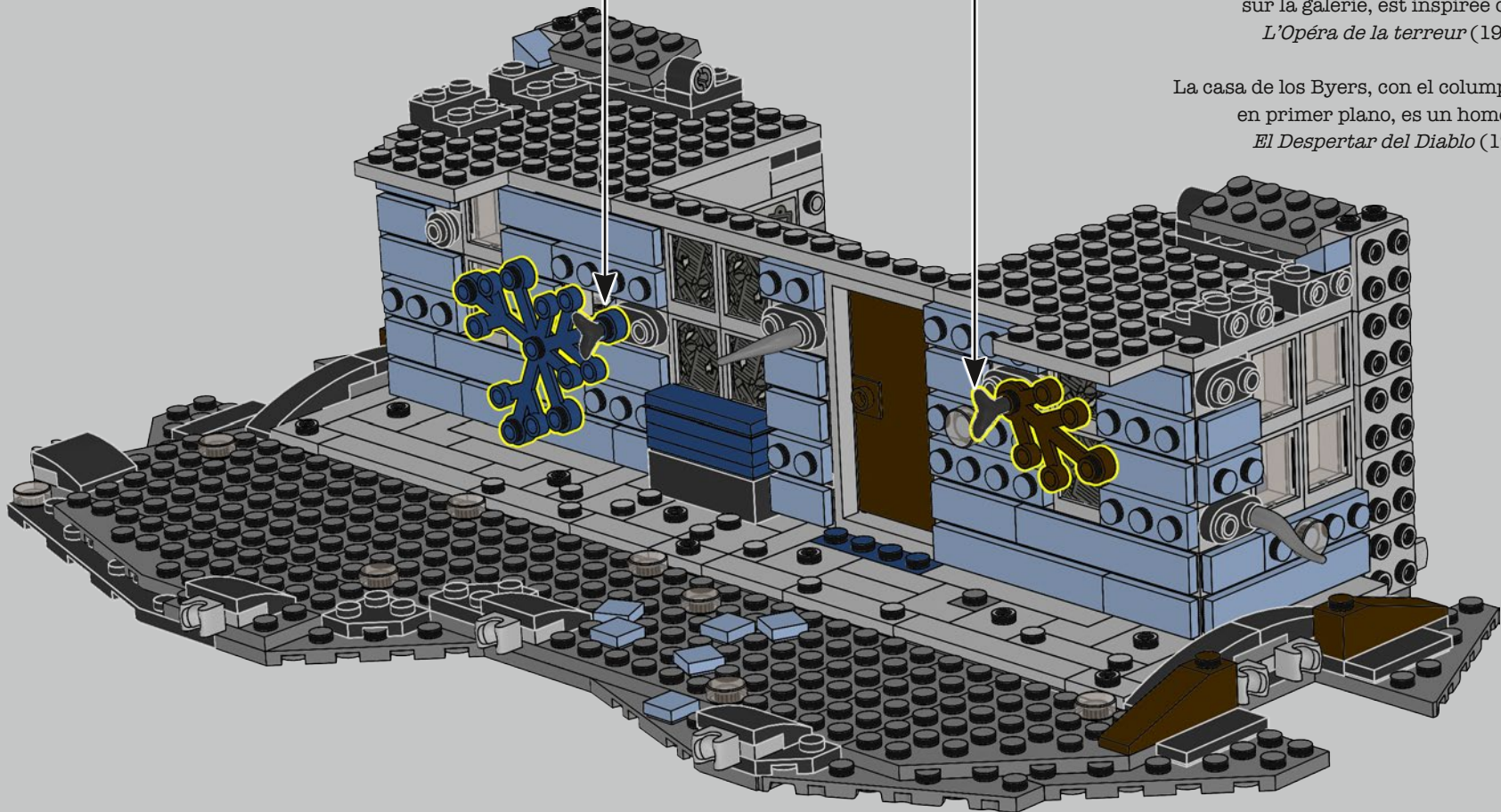

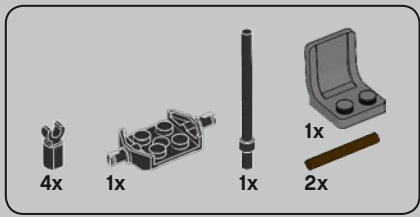

208

1

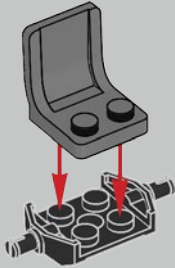

2

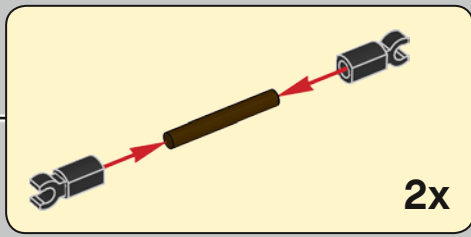
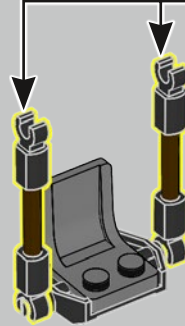

3

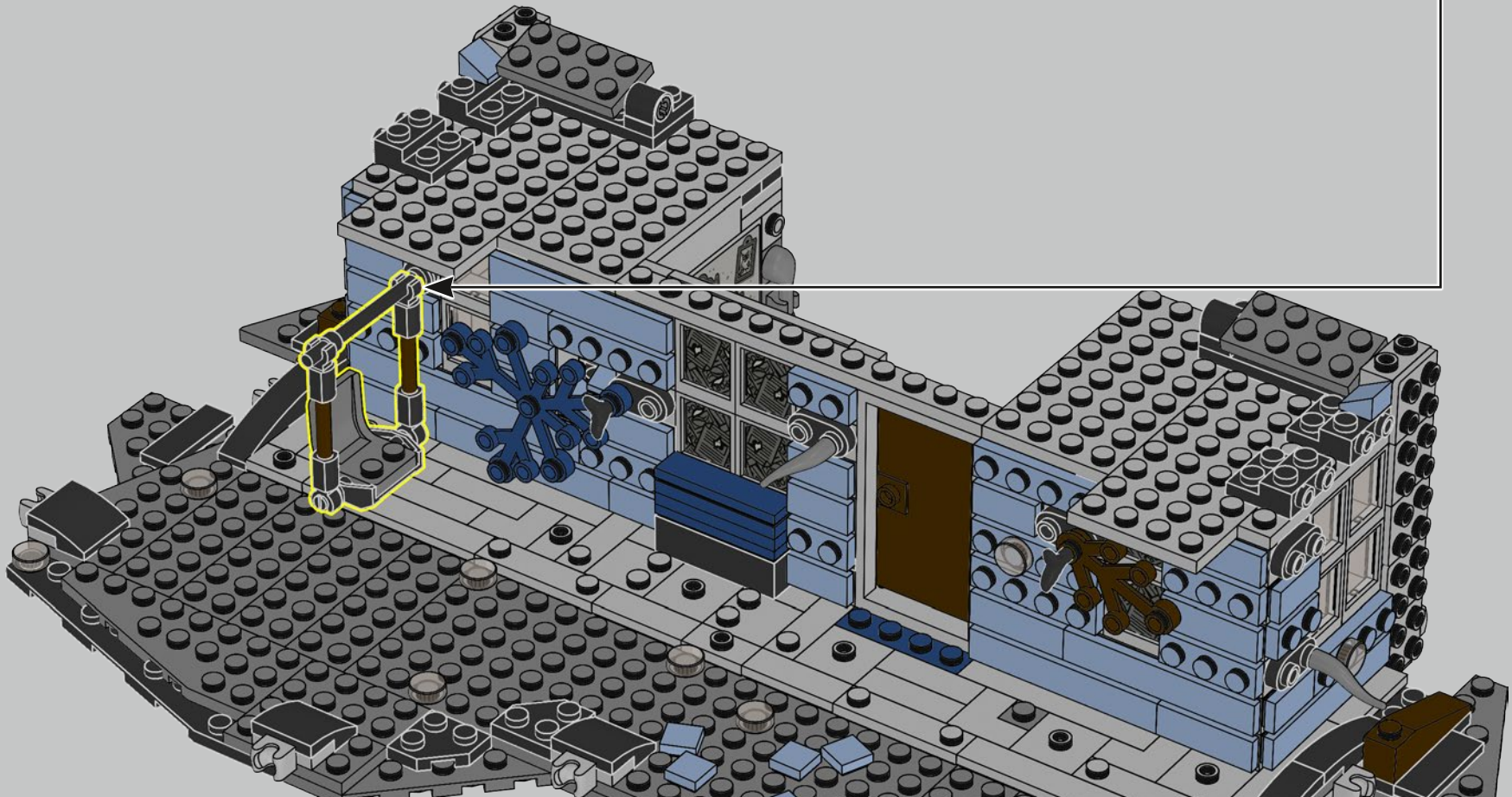
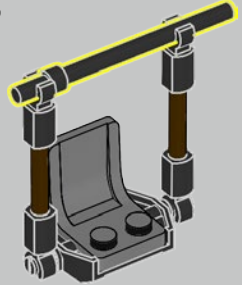

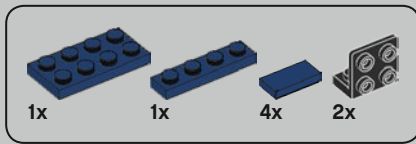

209

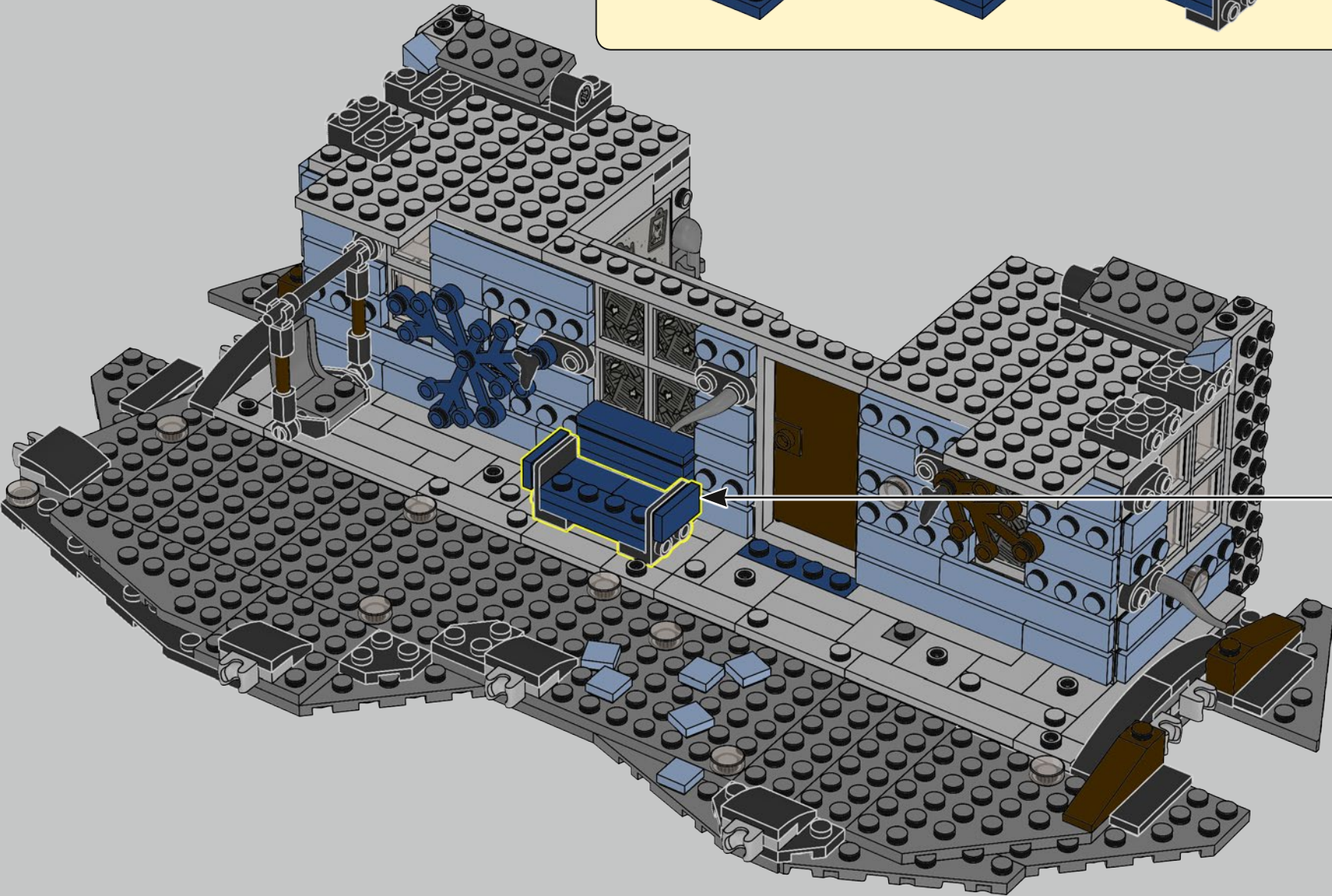
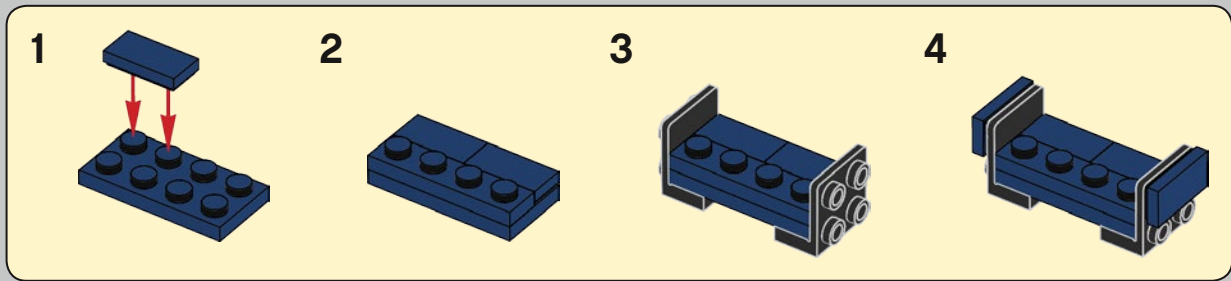

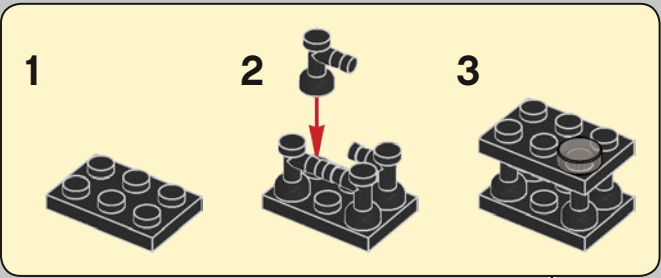
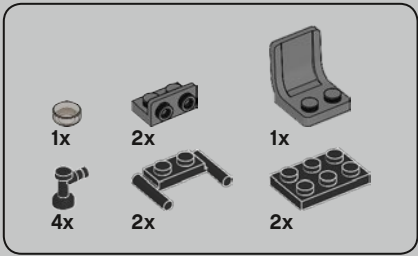

210

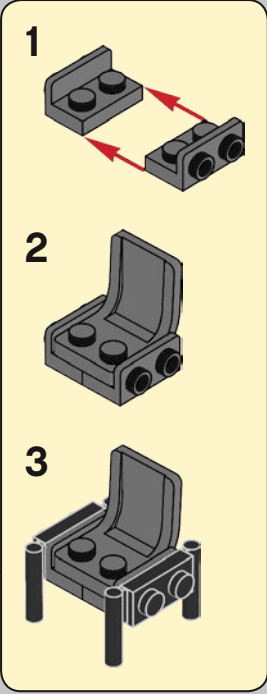
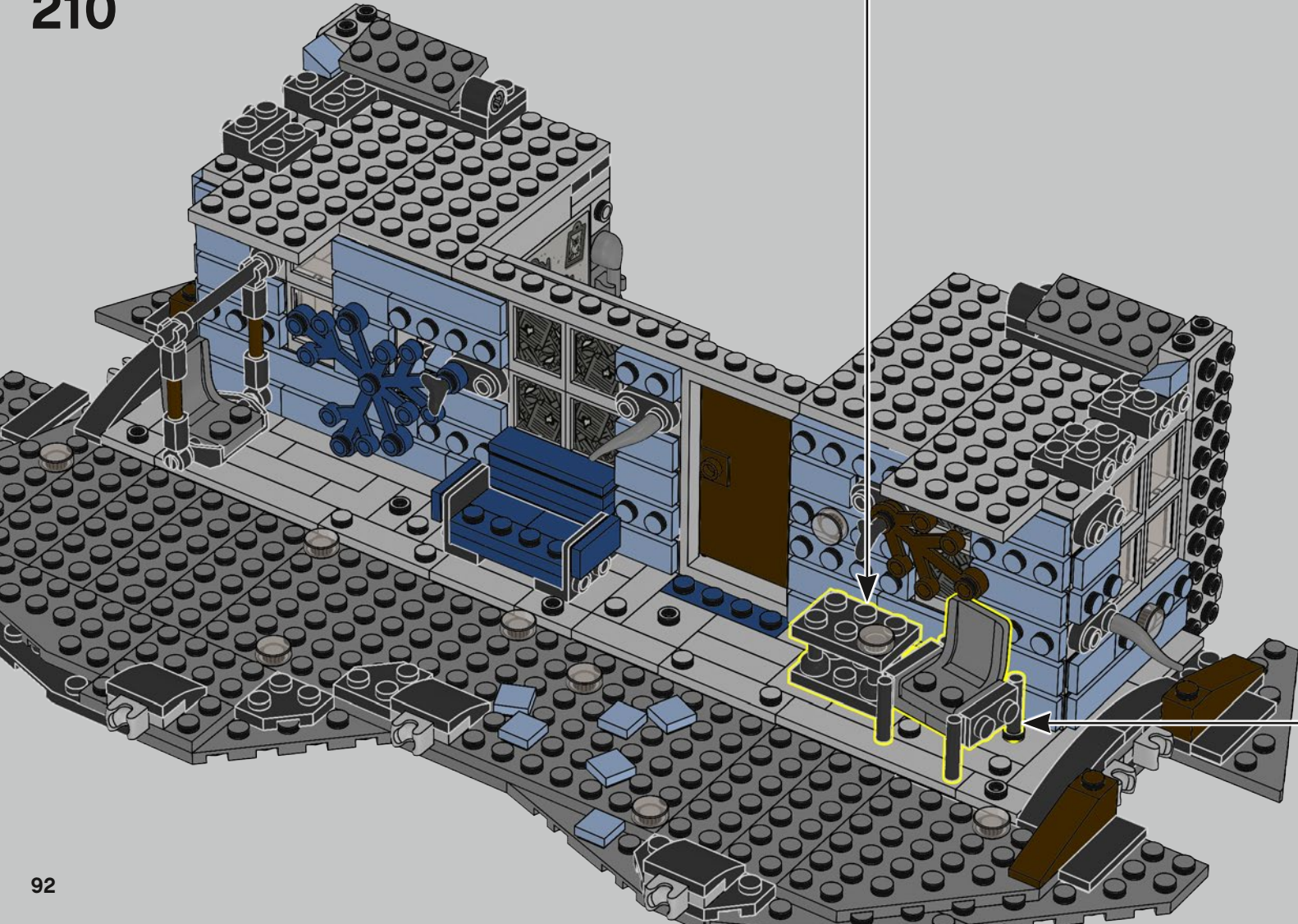

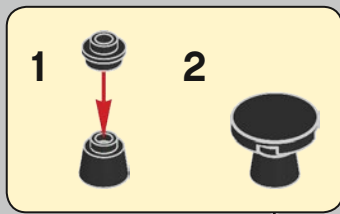
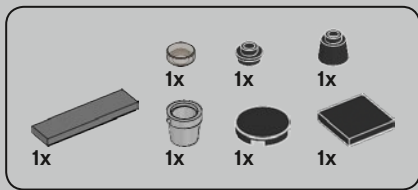

211

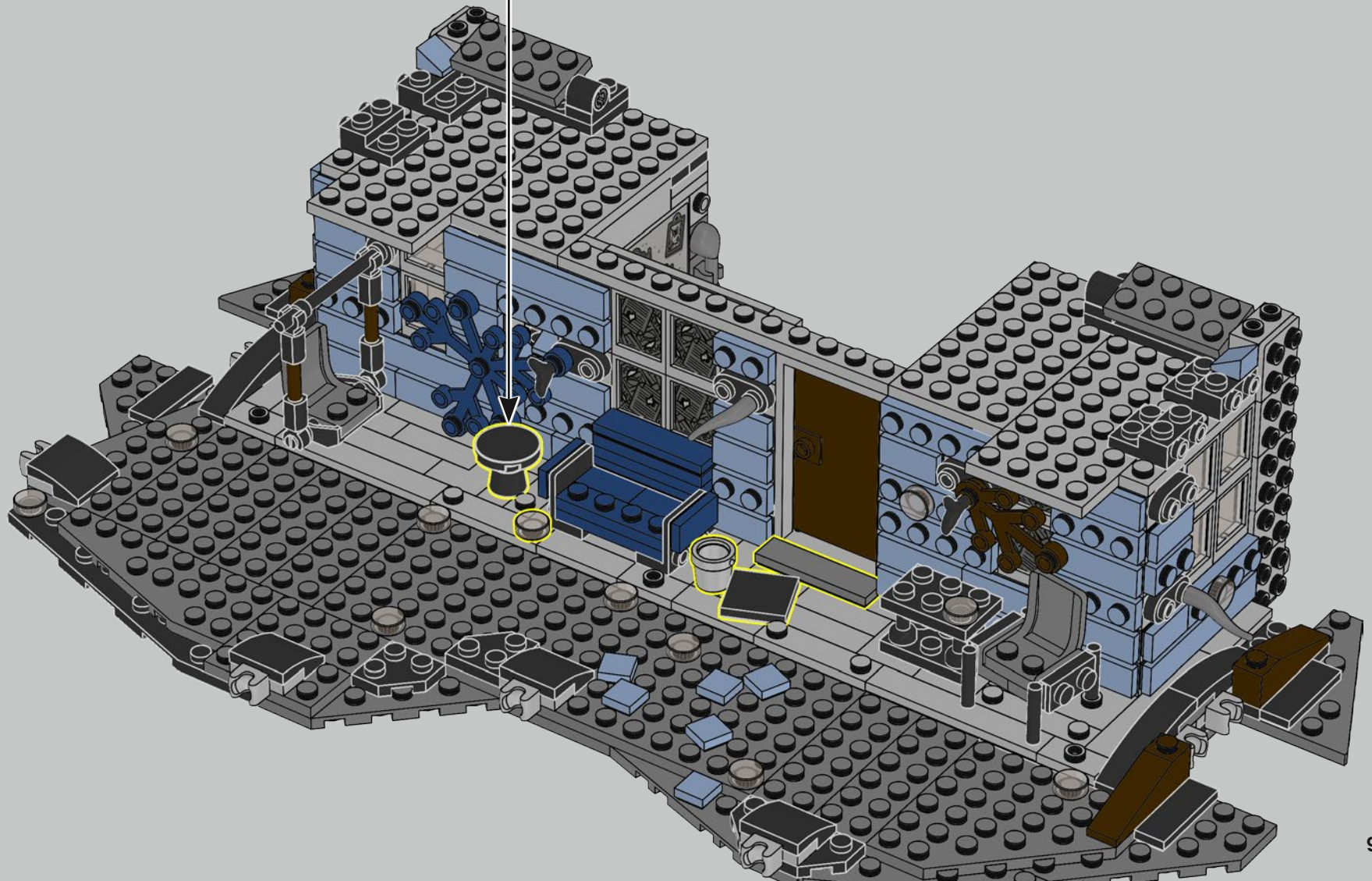

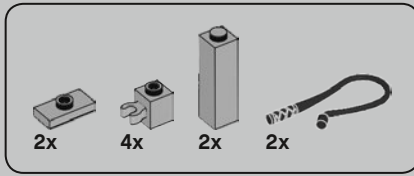
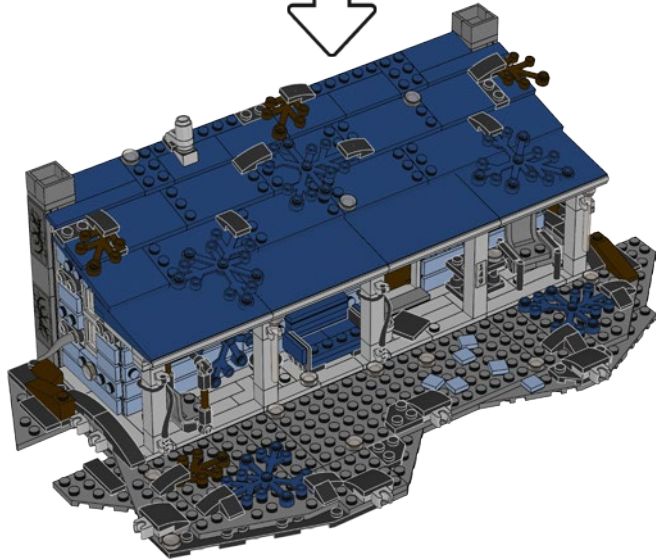

212

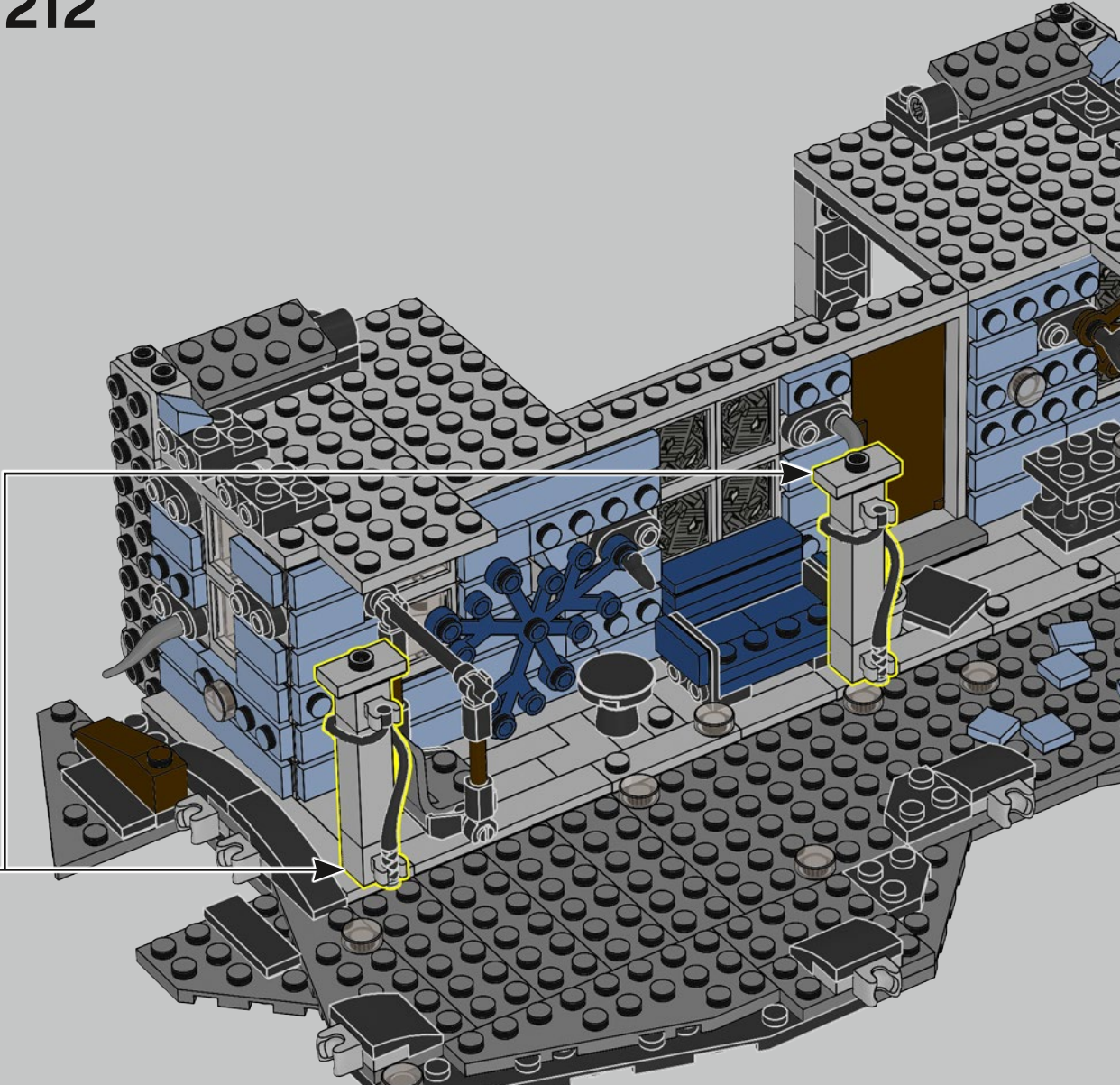
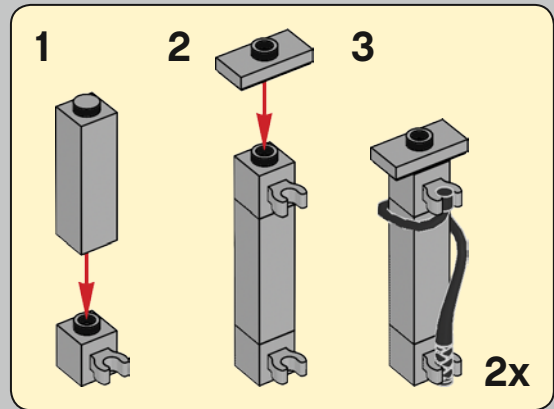

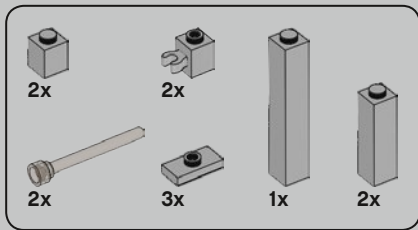

213

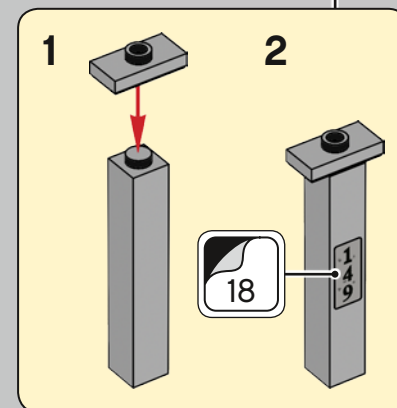
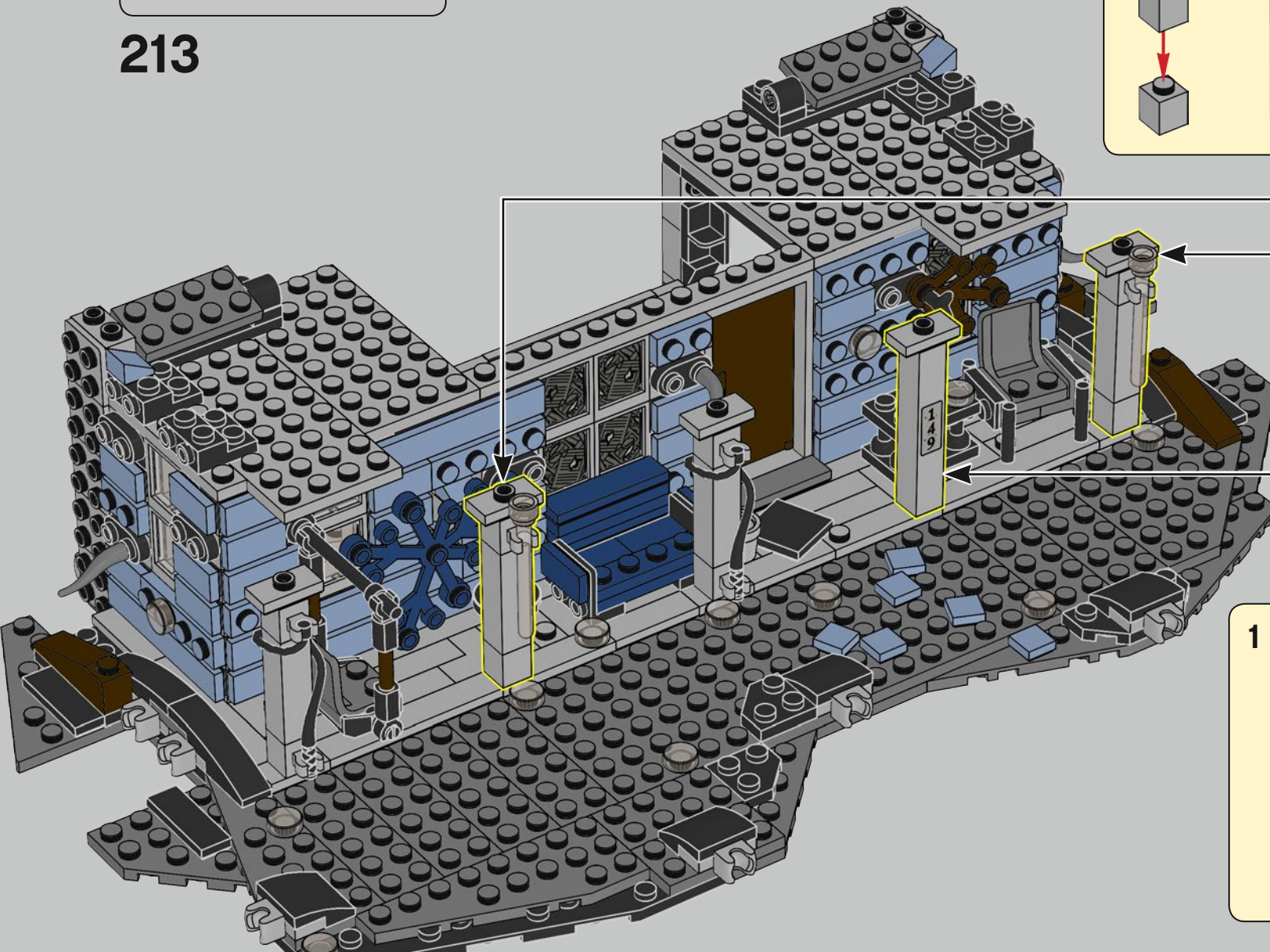
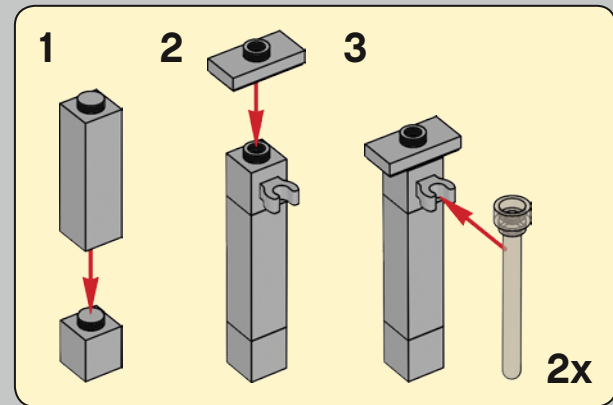

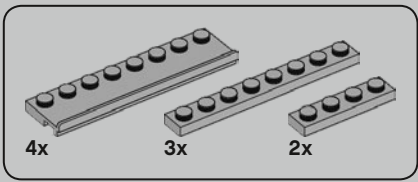

214

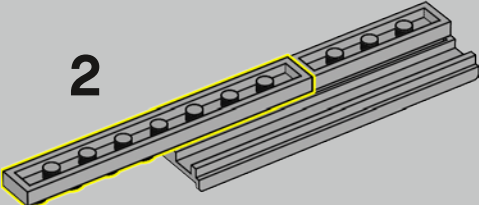
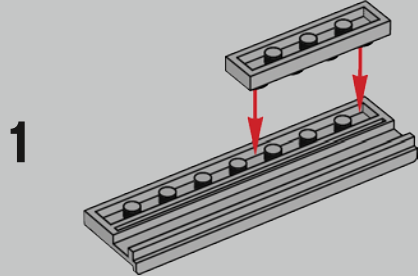

3

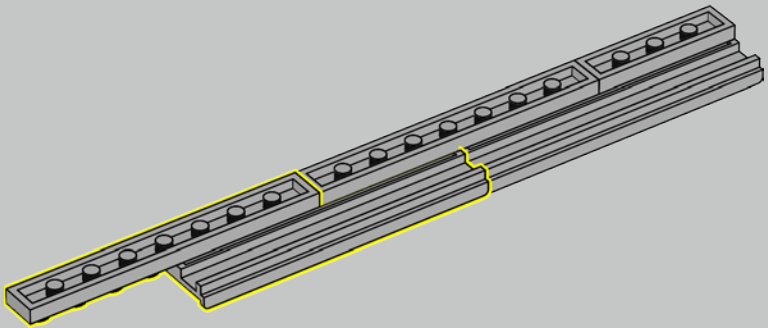

4

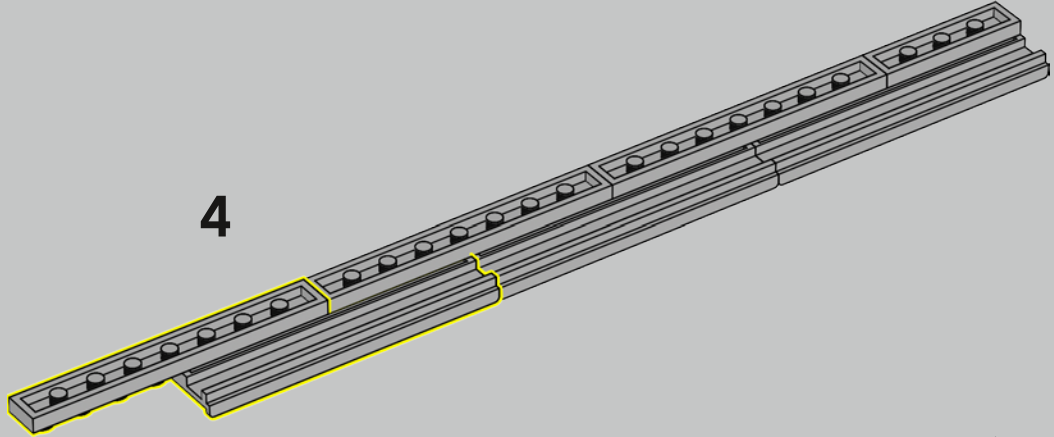

5

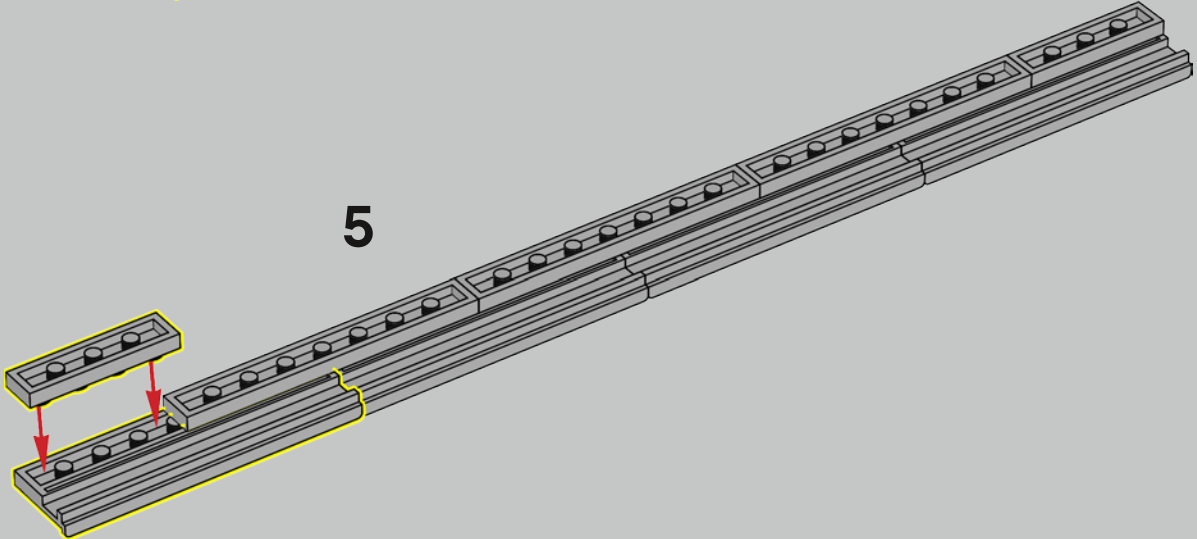

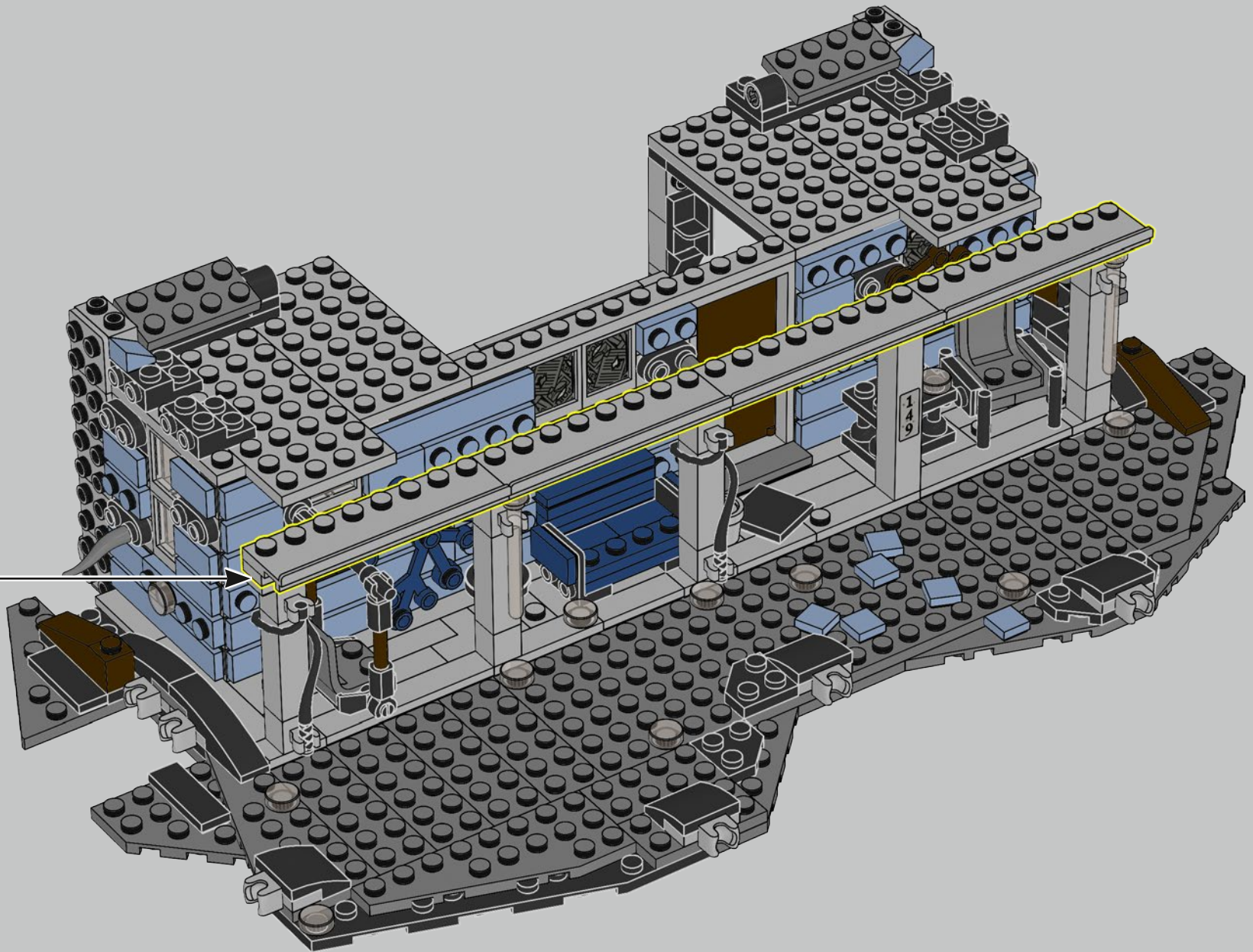

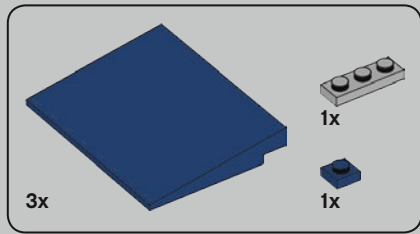

215

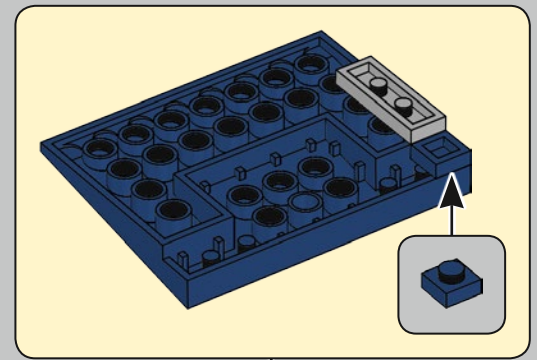
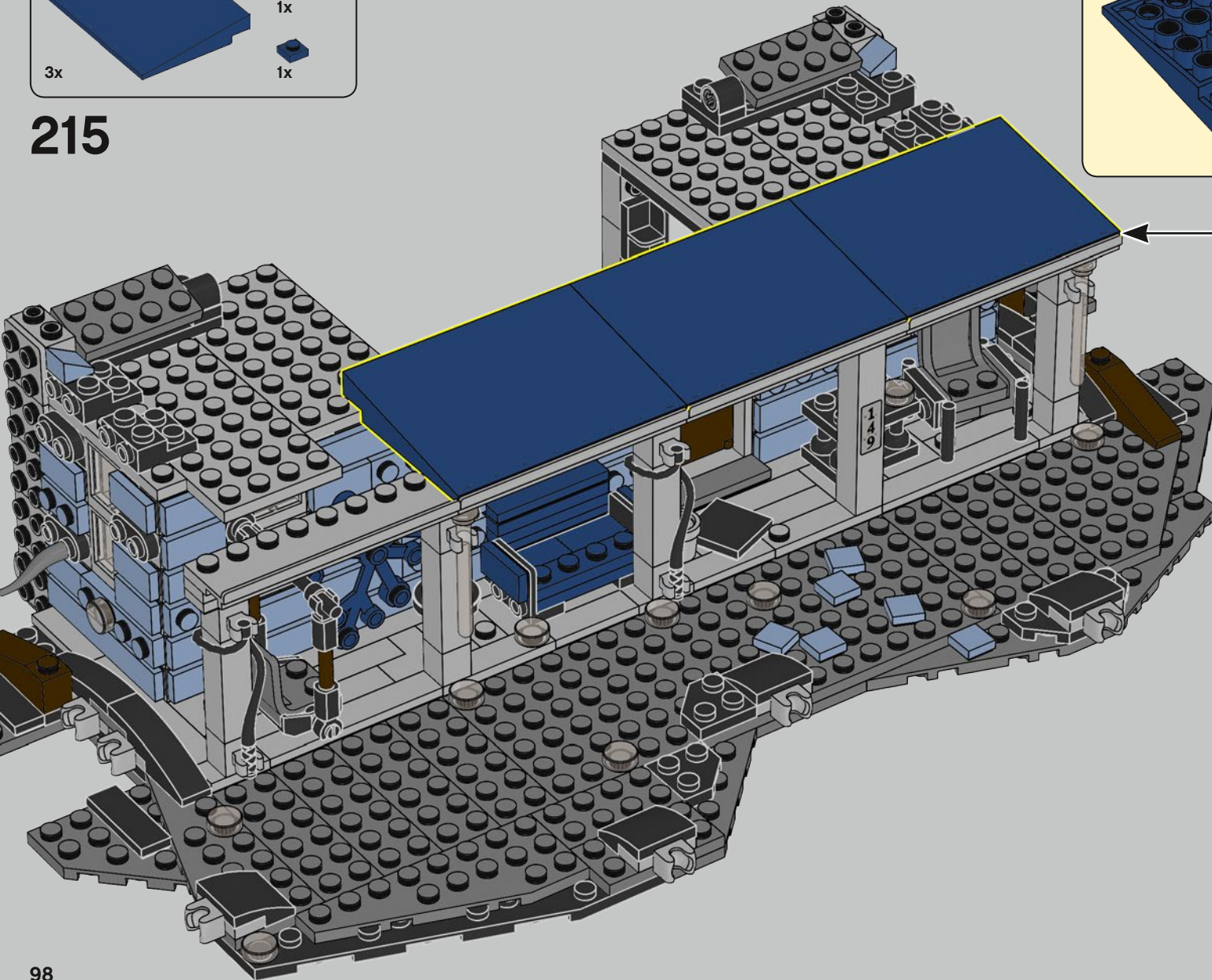

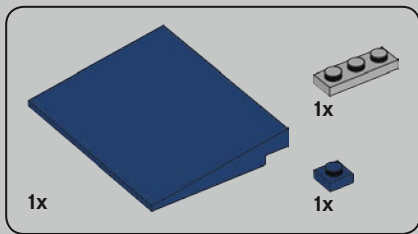

216

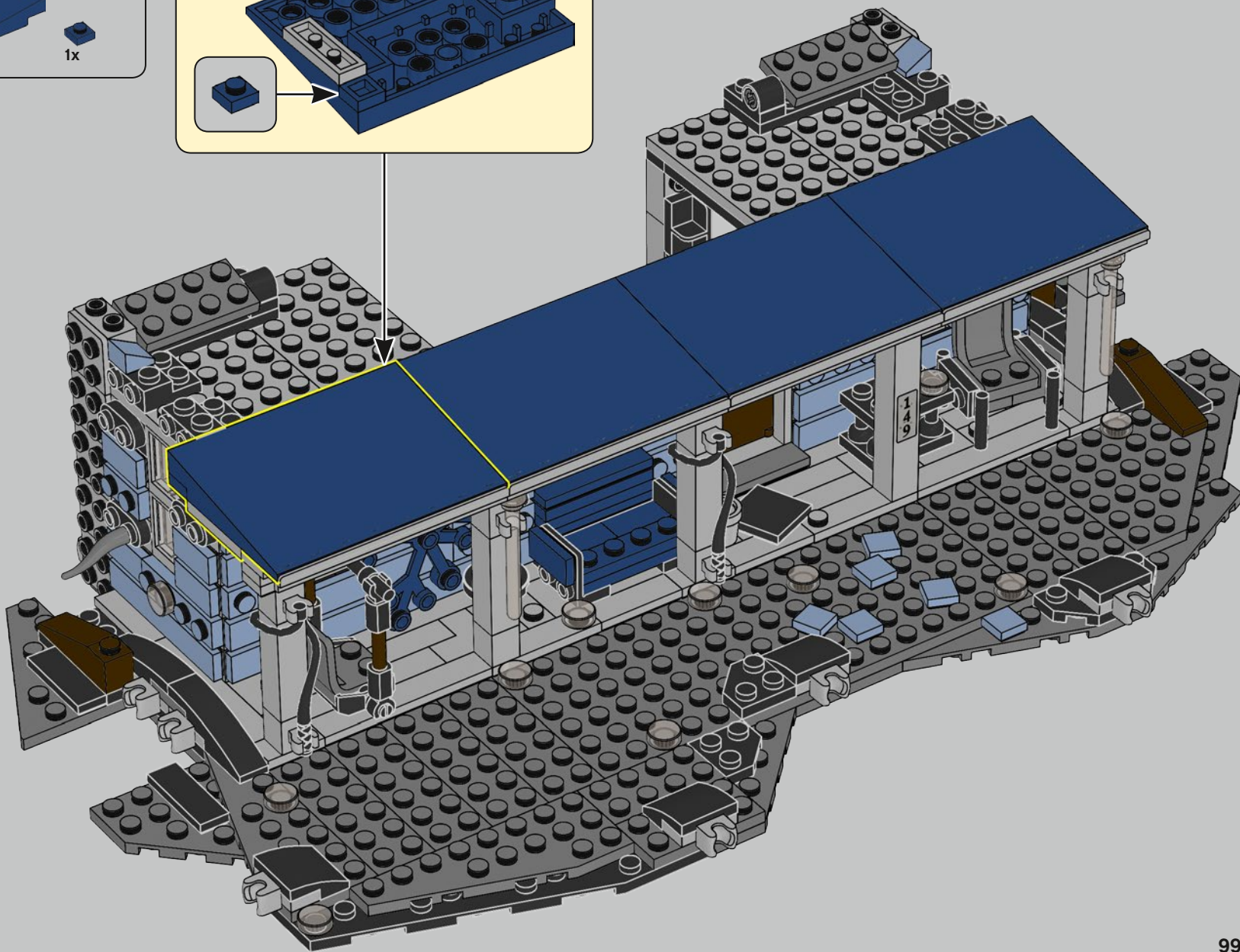
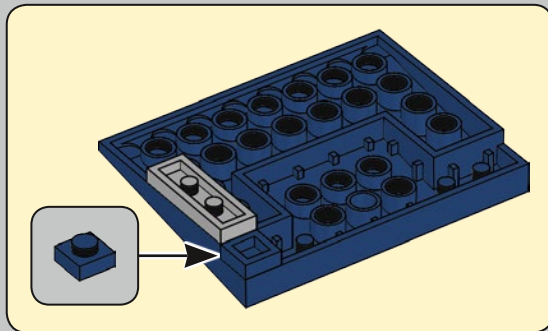

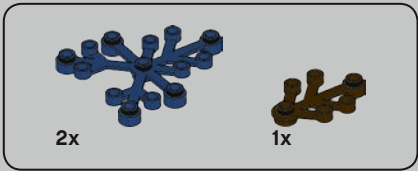

217

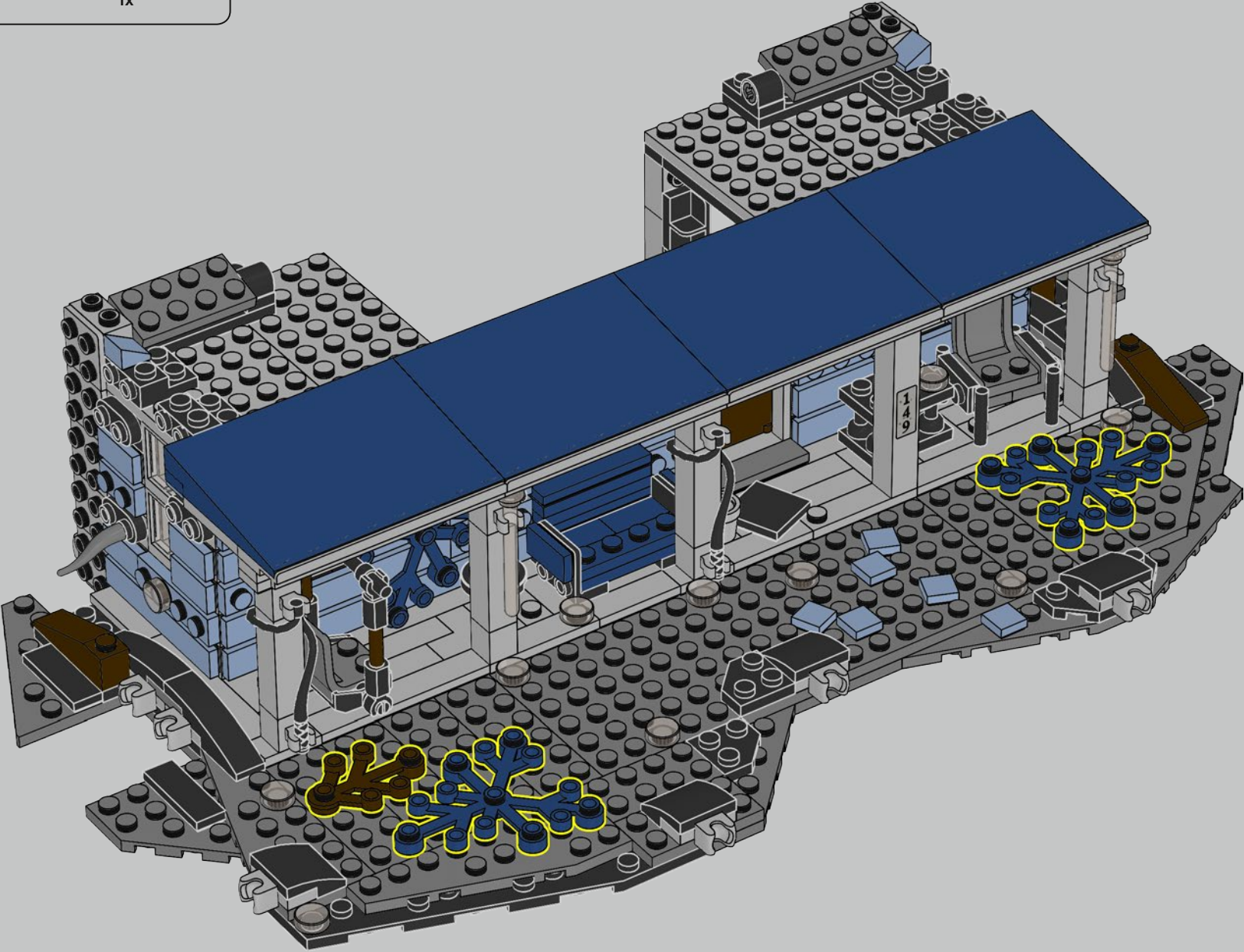



4x



5x

218

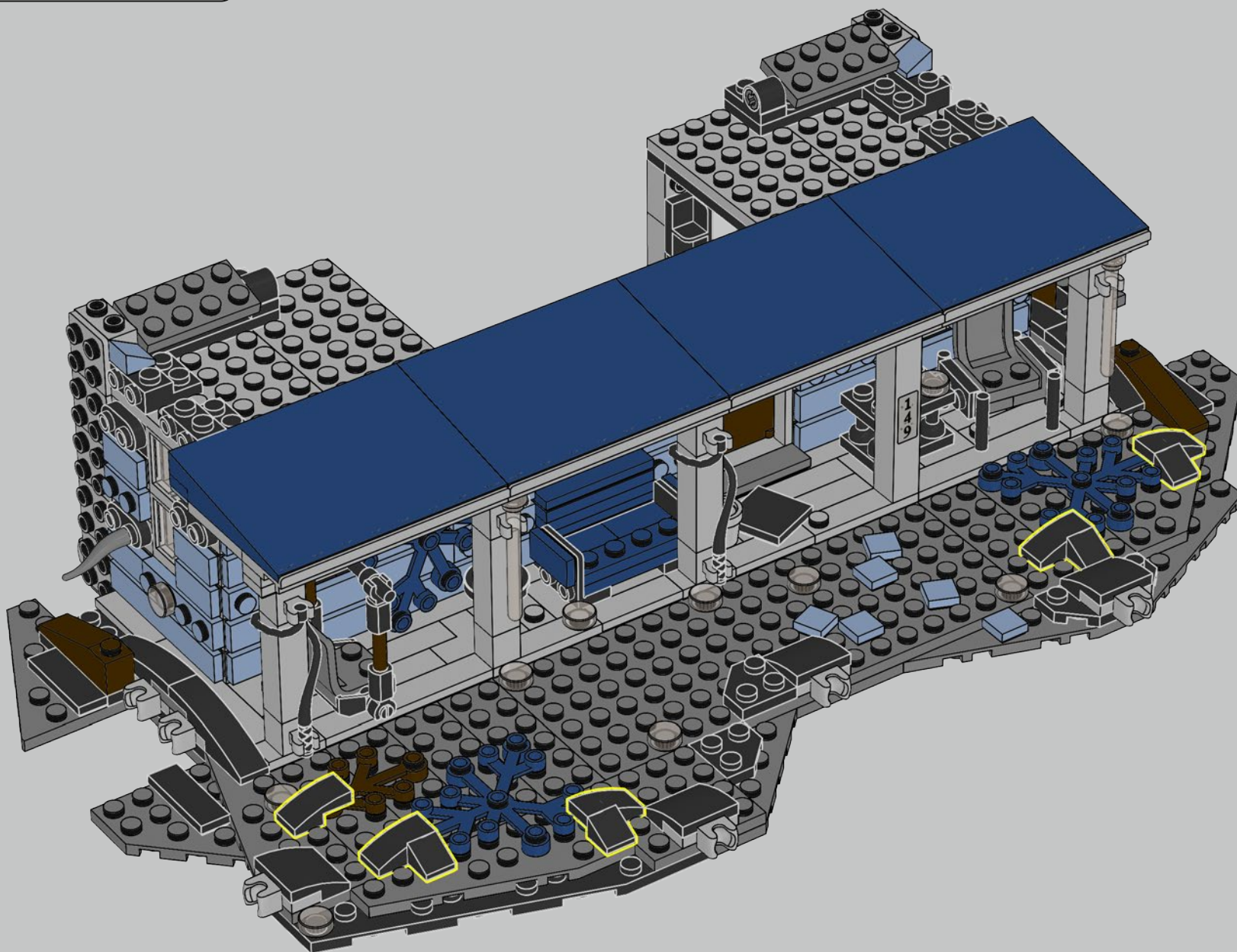



1x



2x

219

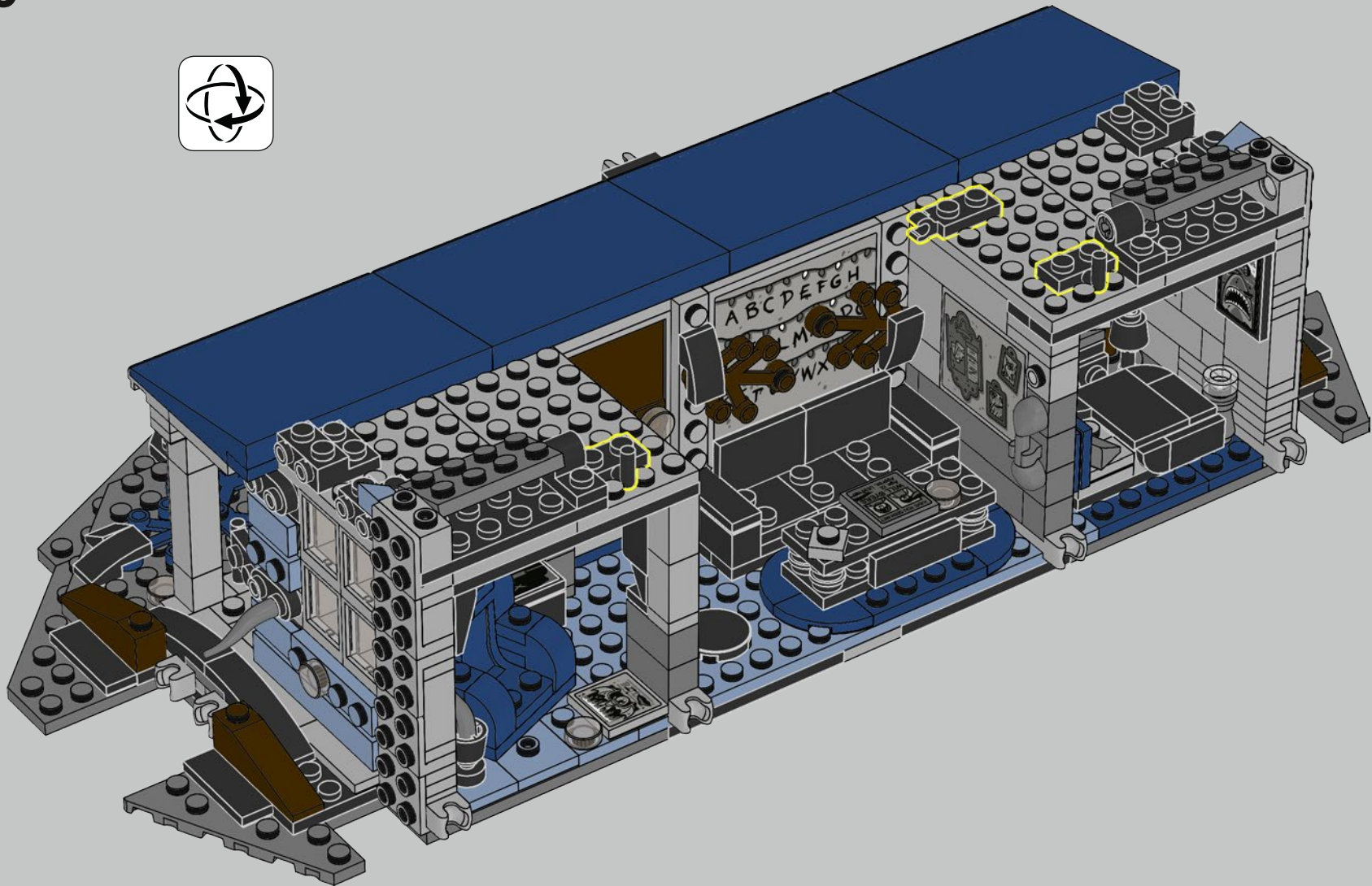

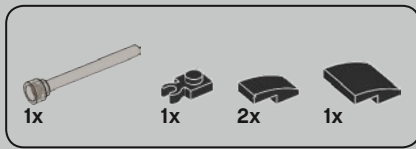

220

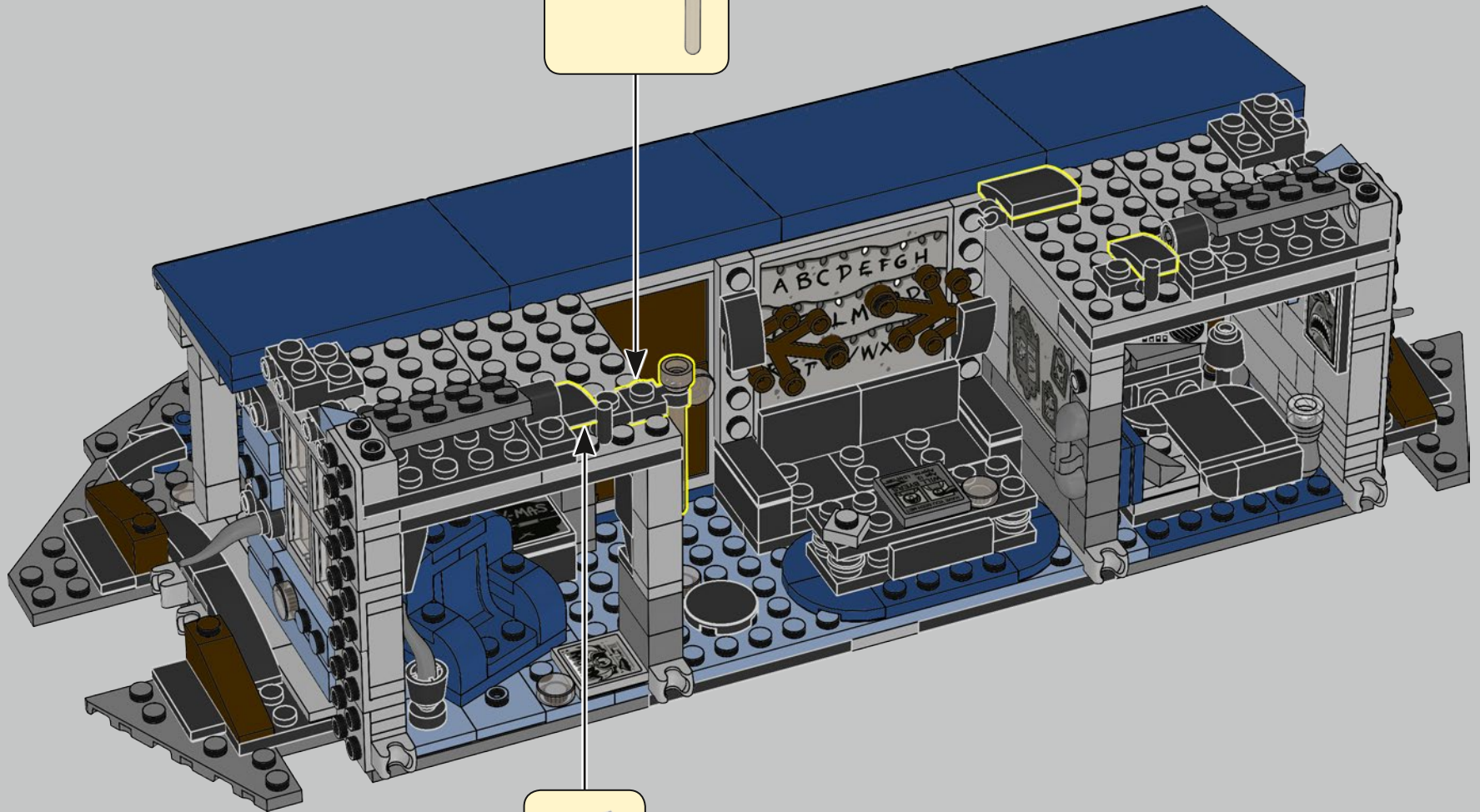
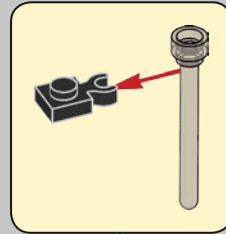

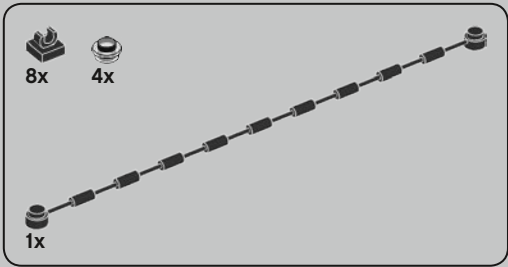

221

1

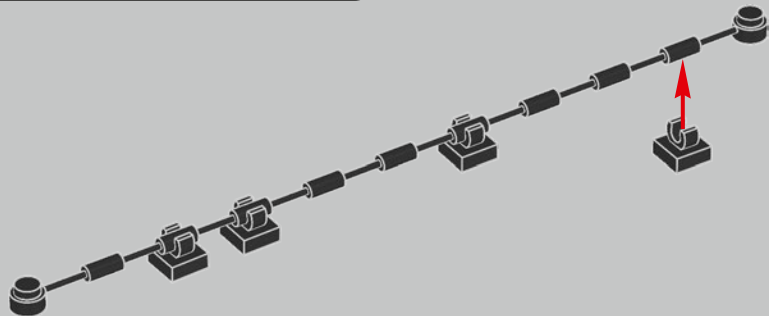

2

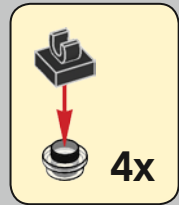
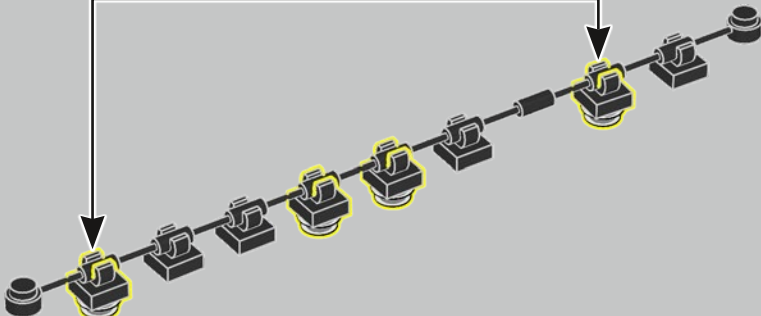

4x

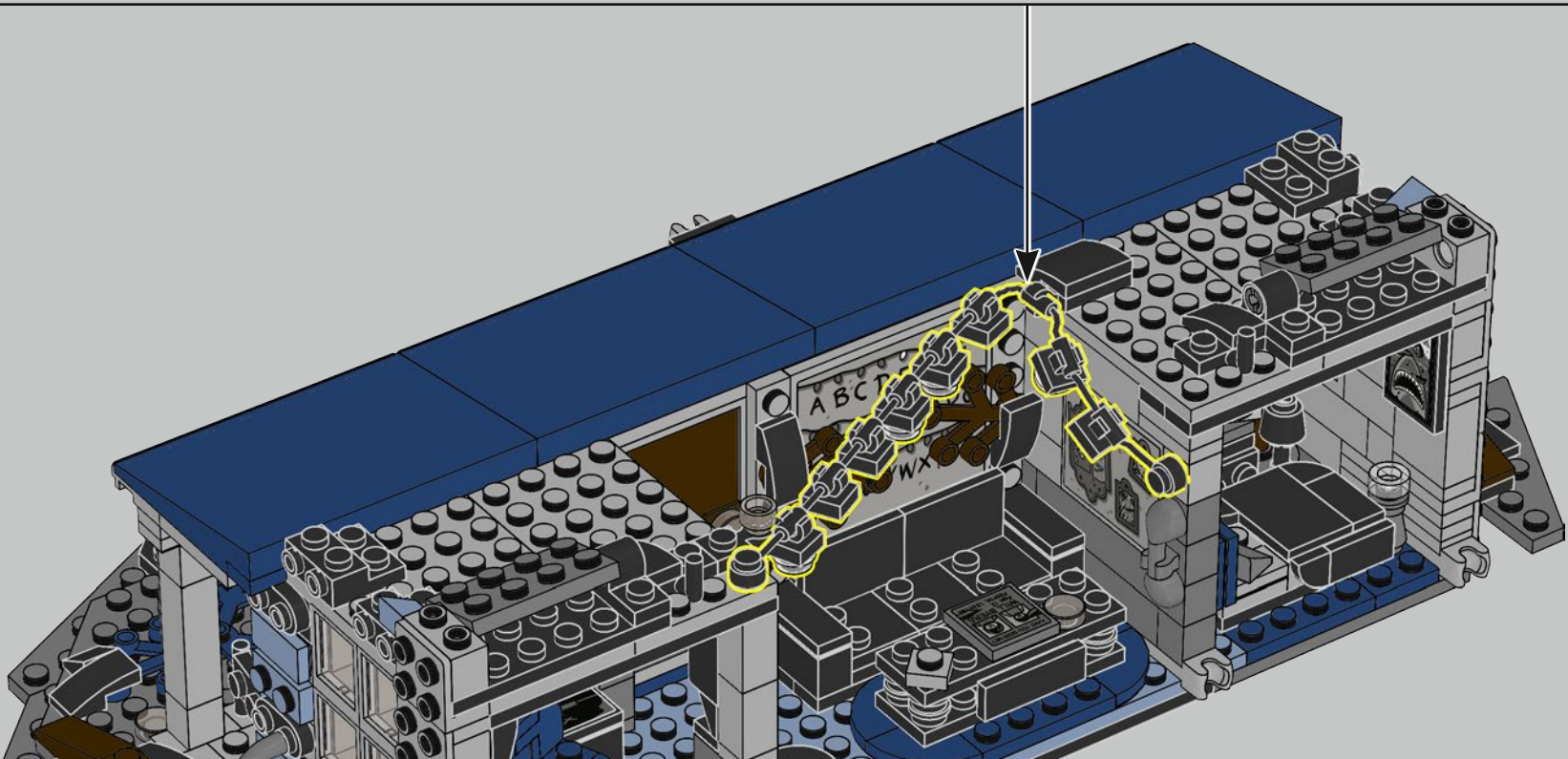

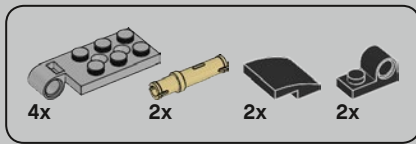

222

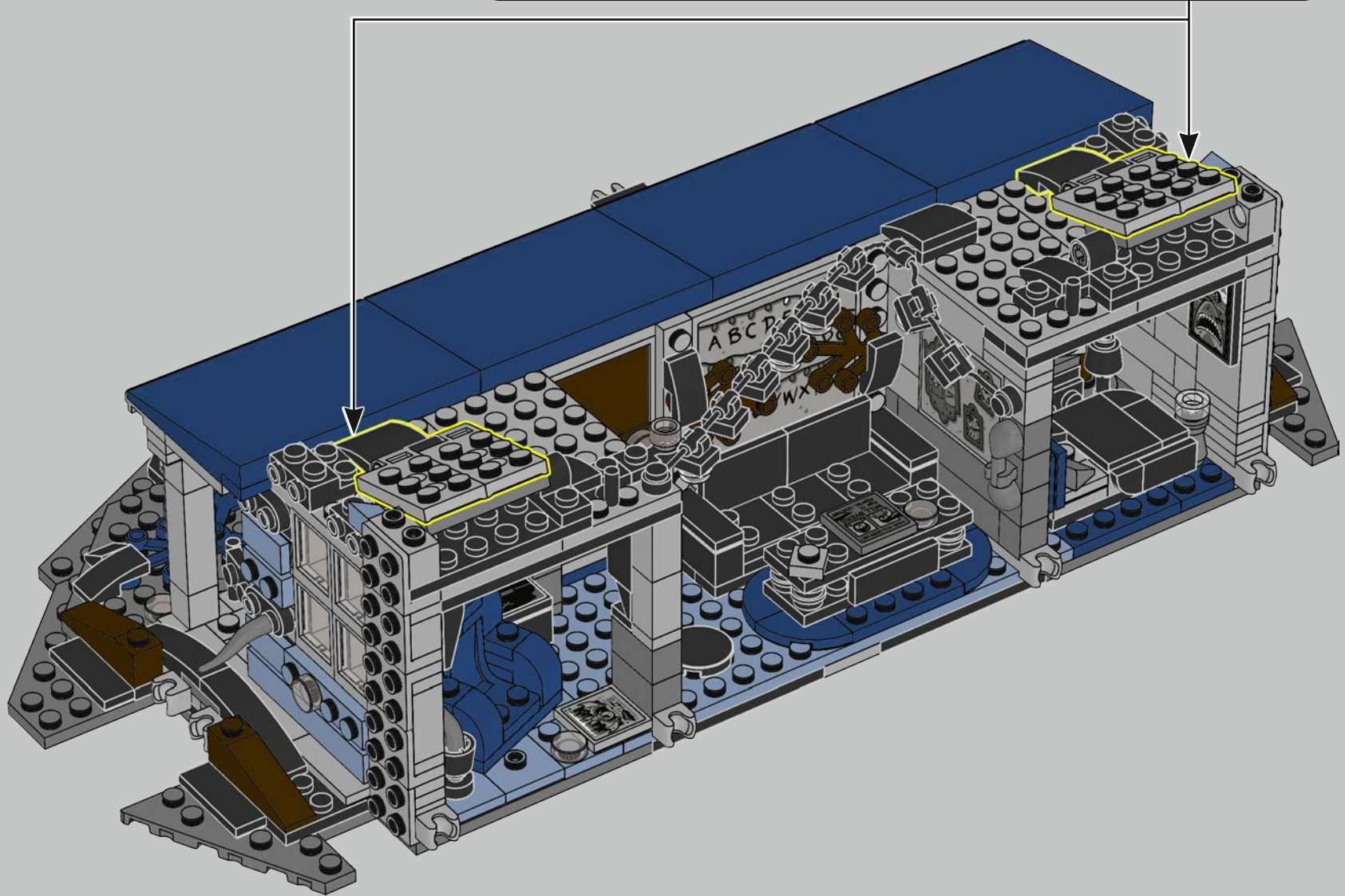
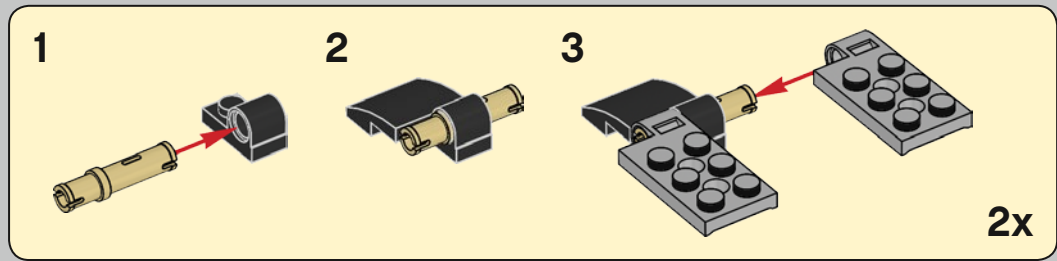

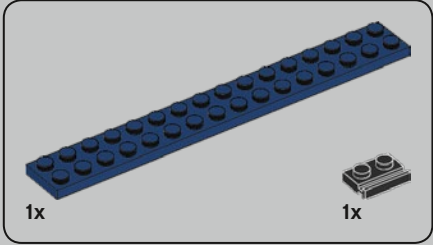
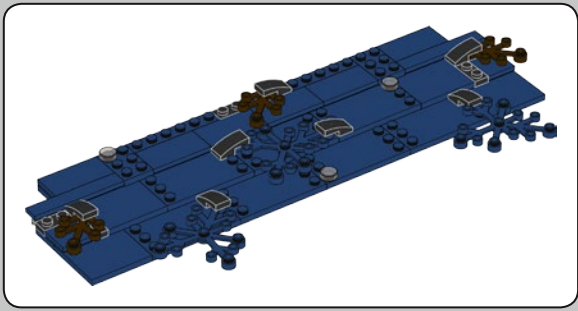

223

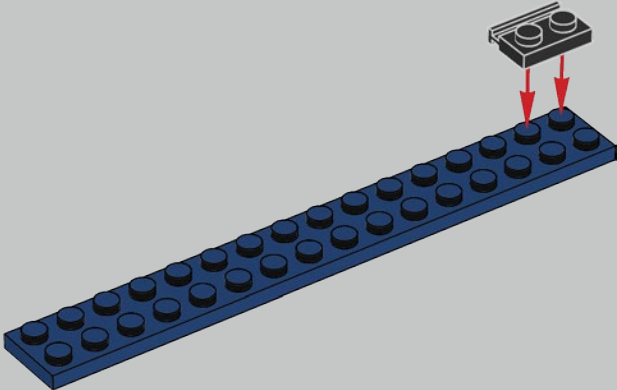

224

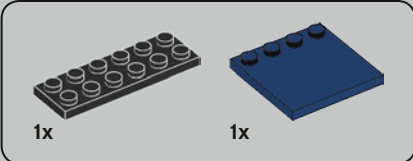
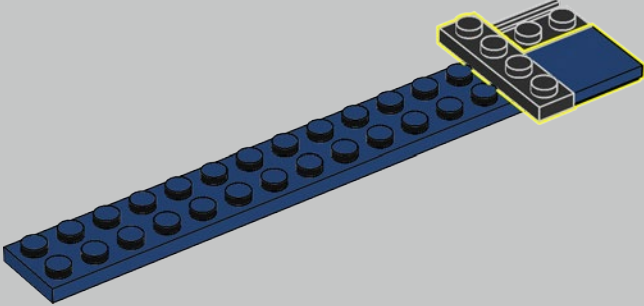

225

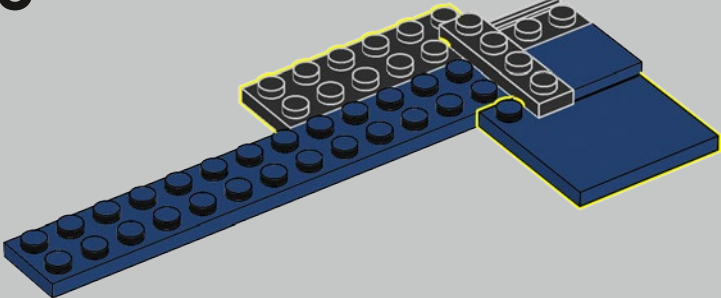

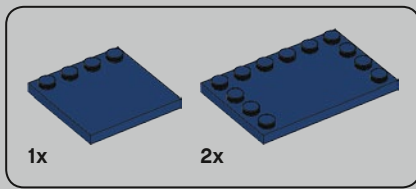

226

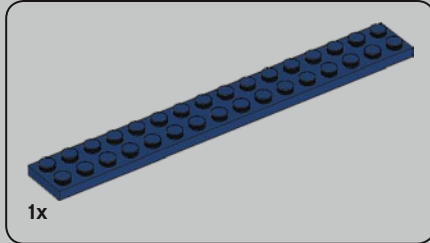
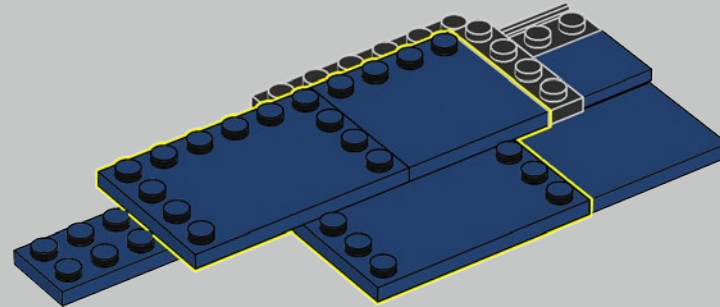

227

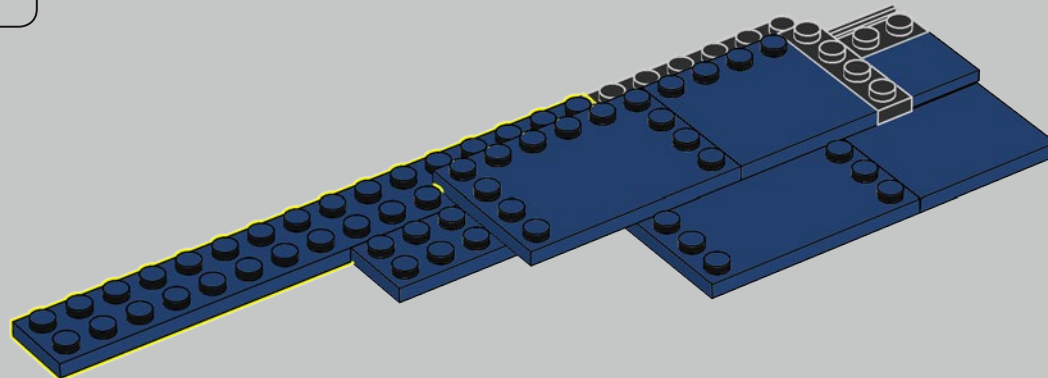

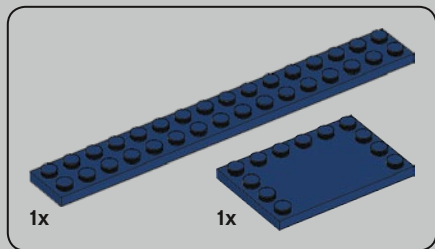

228

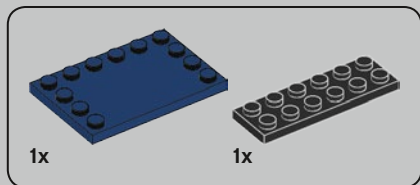
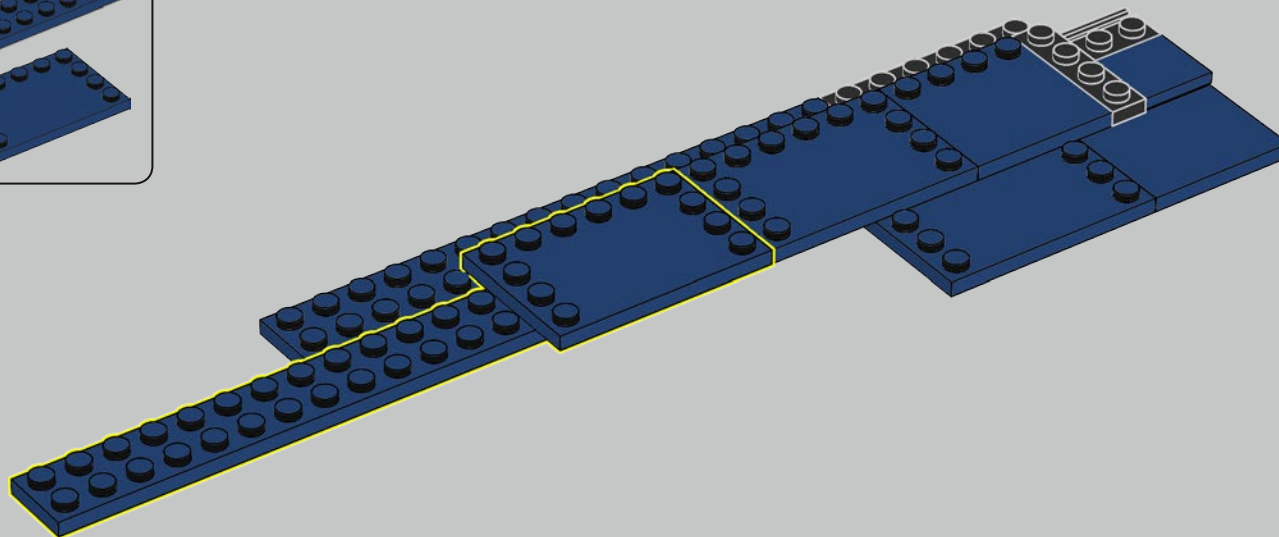

229

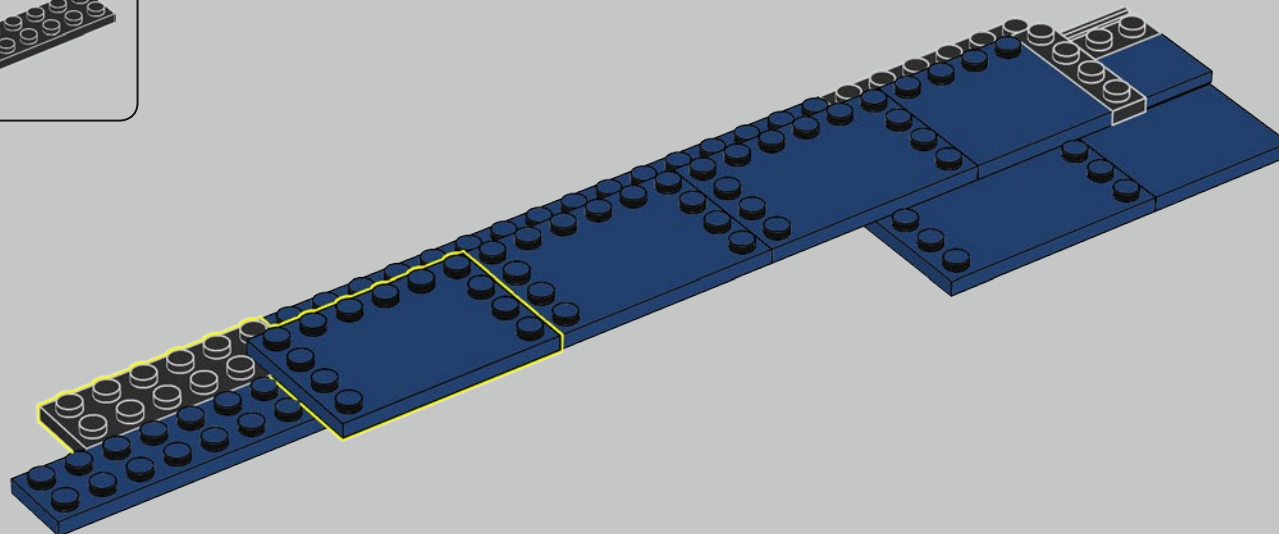

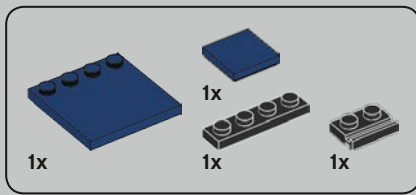

230

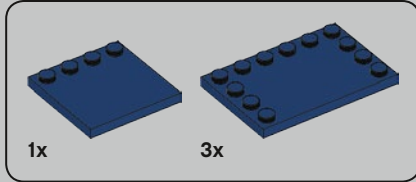
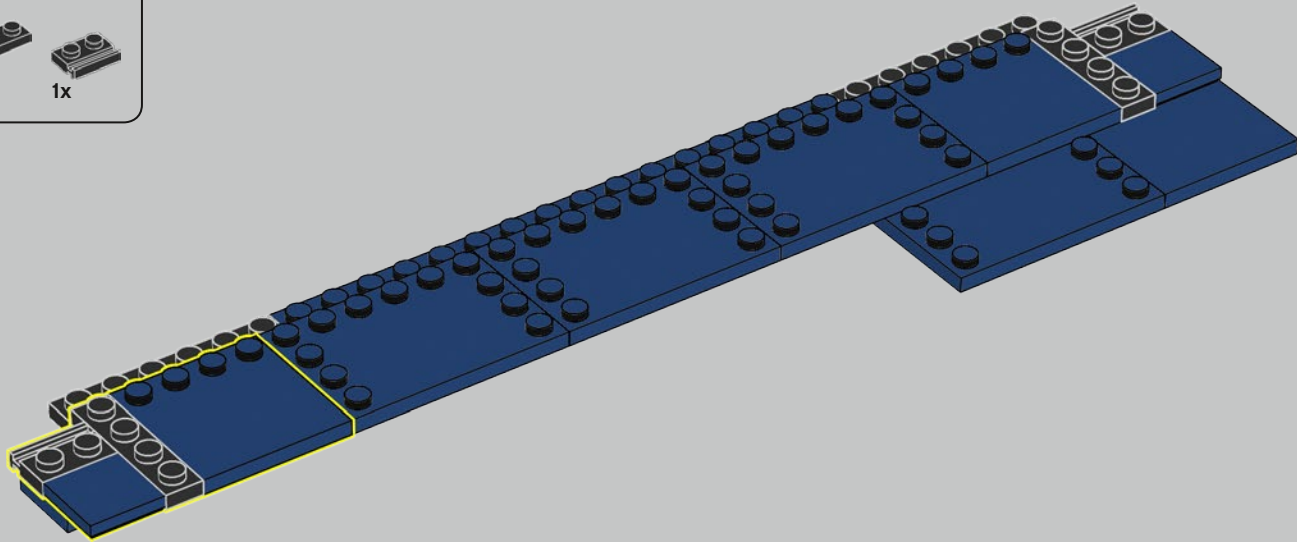

231

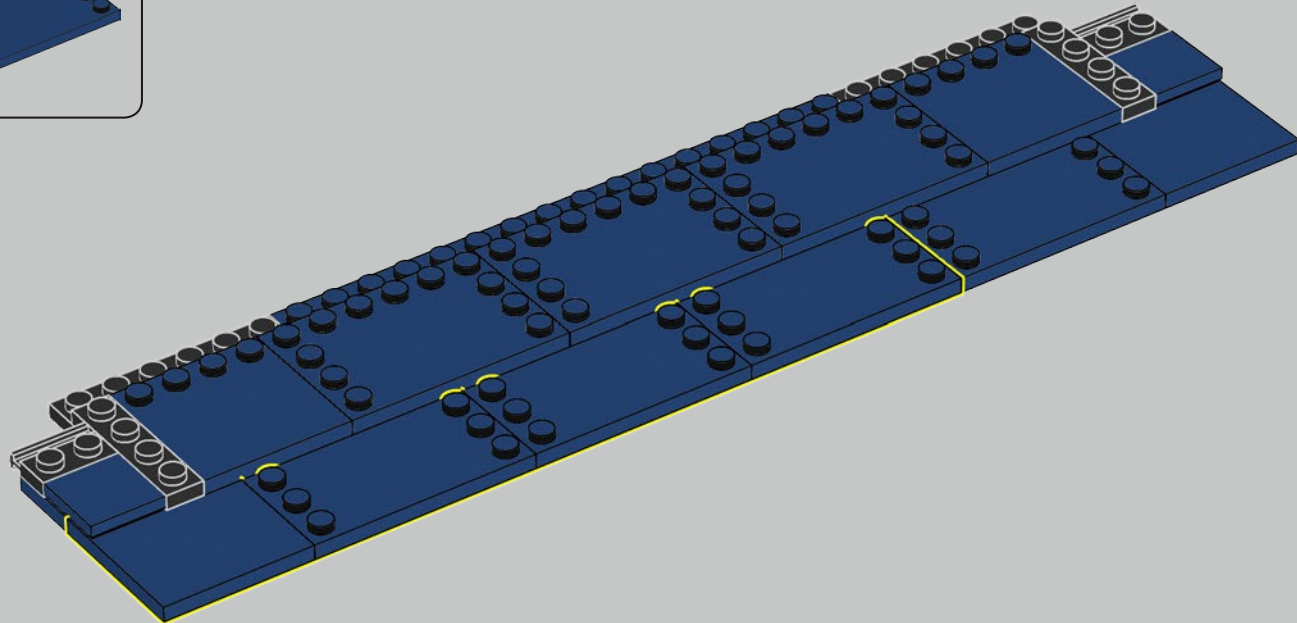

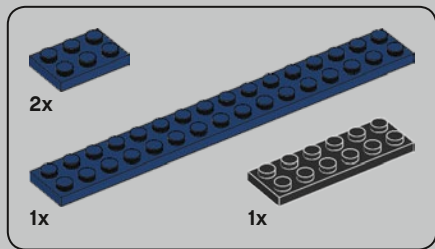

232

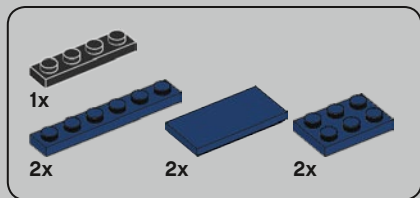
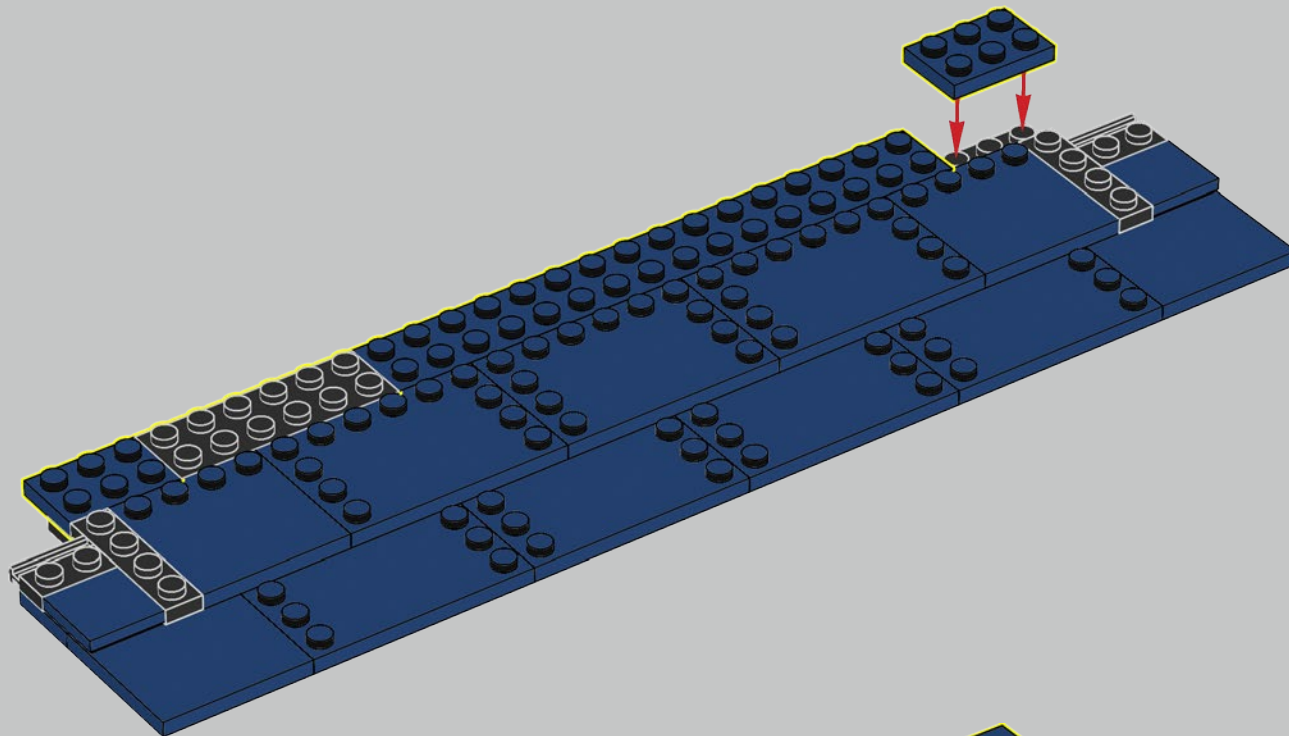

233

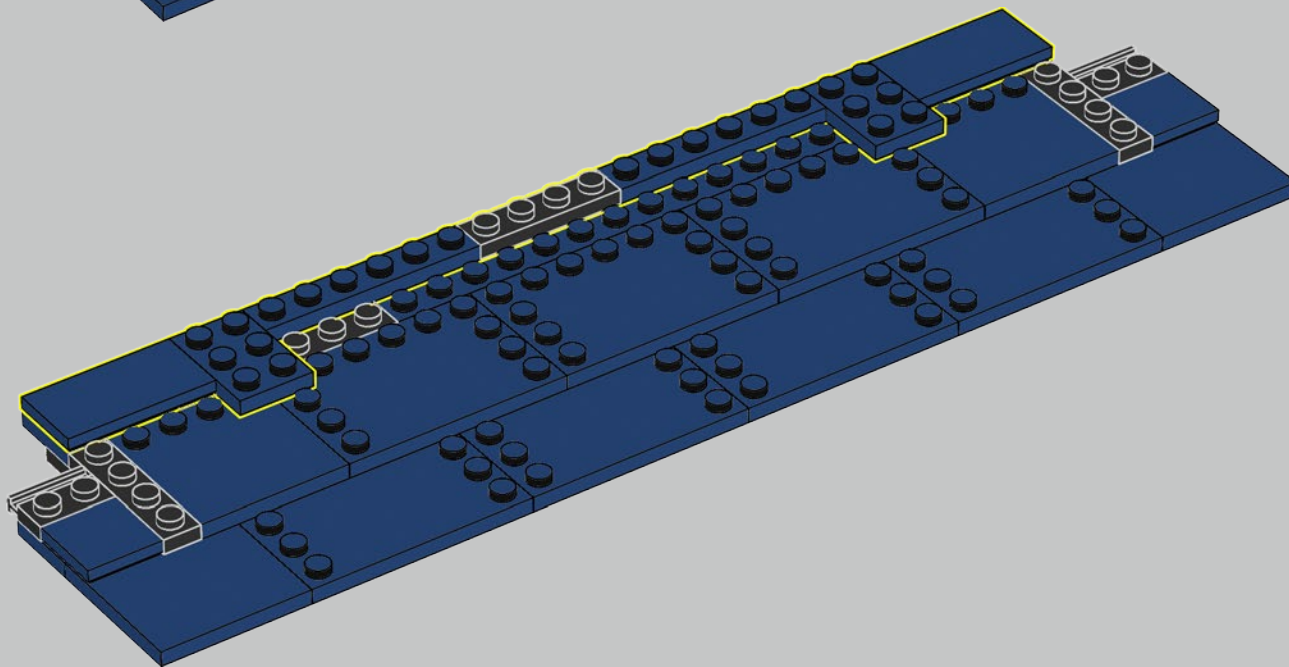

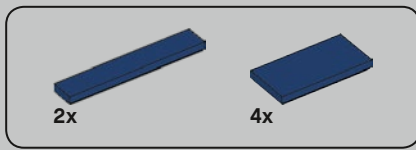

234

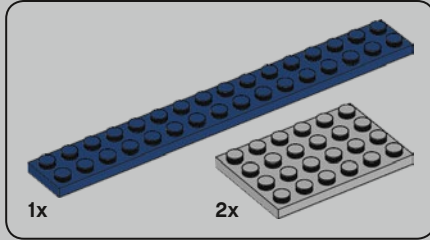
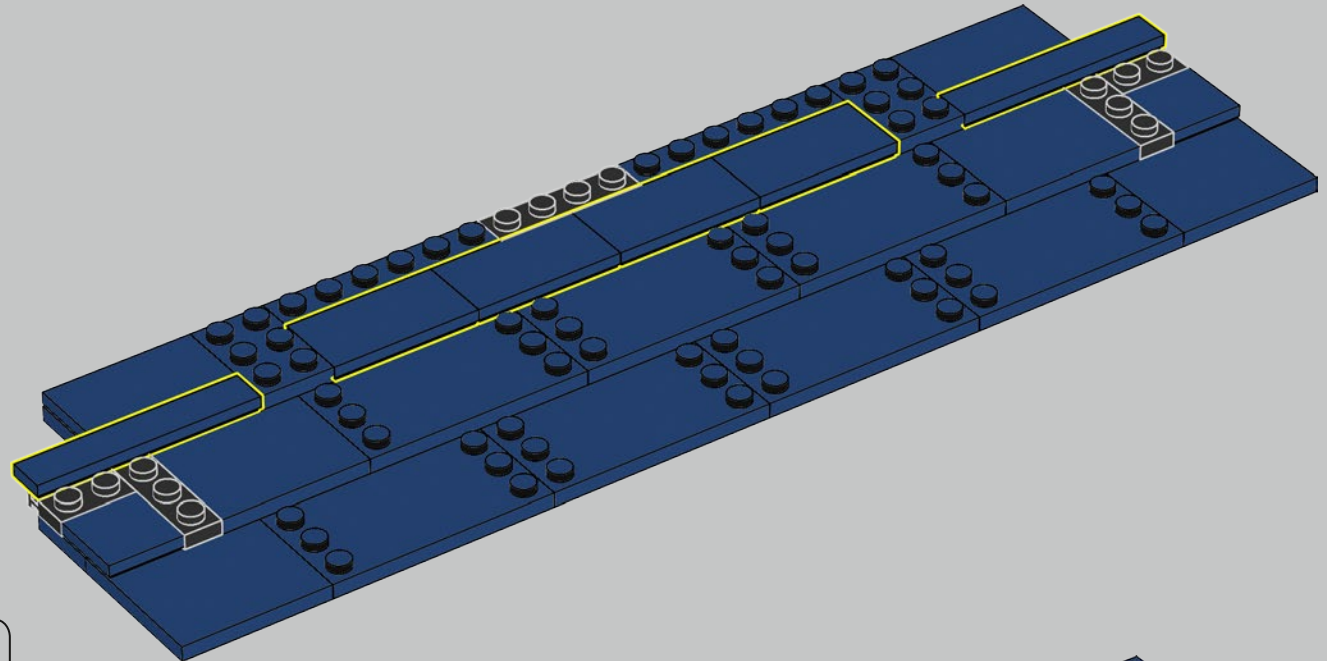

235

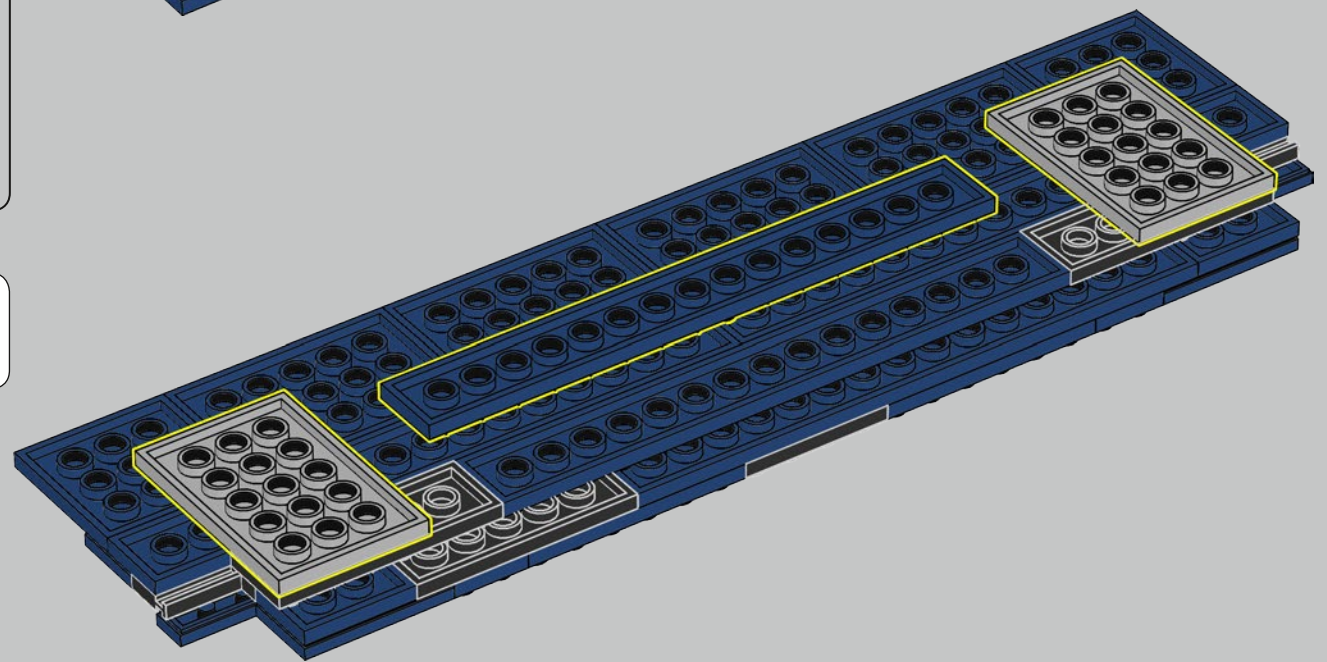

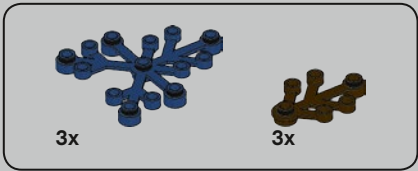

236

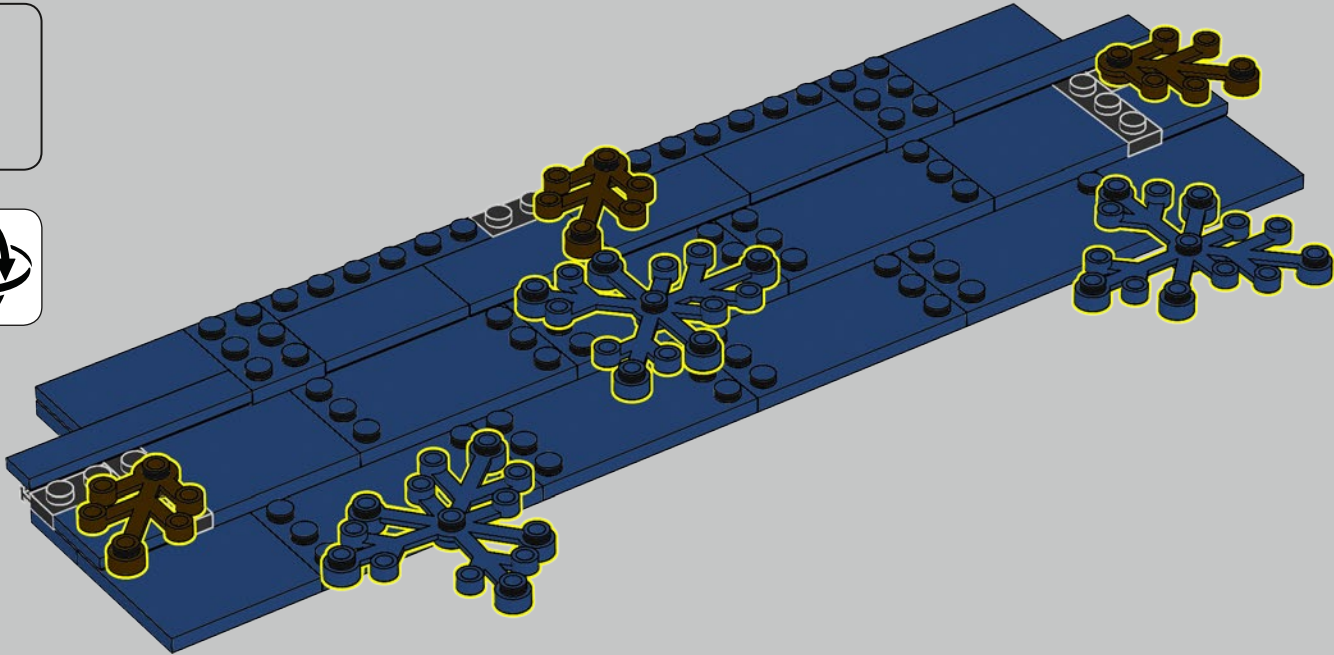

237

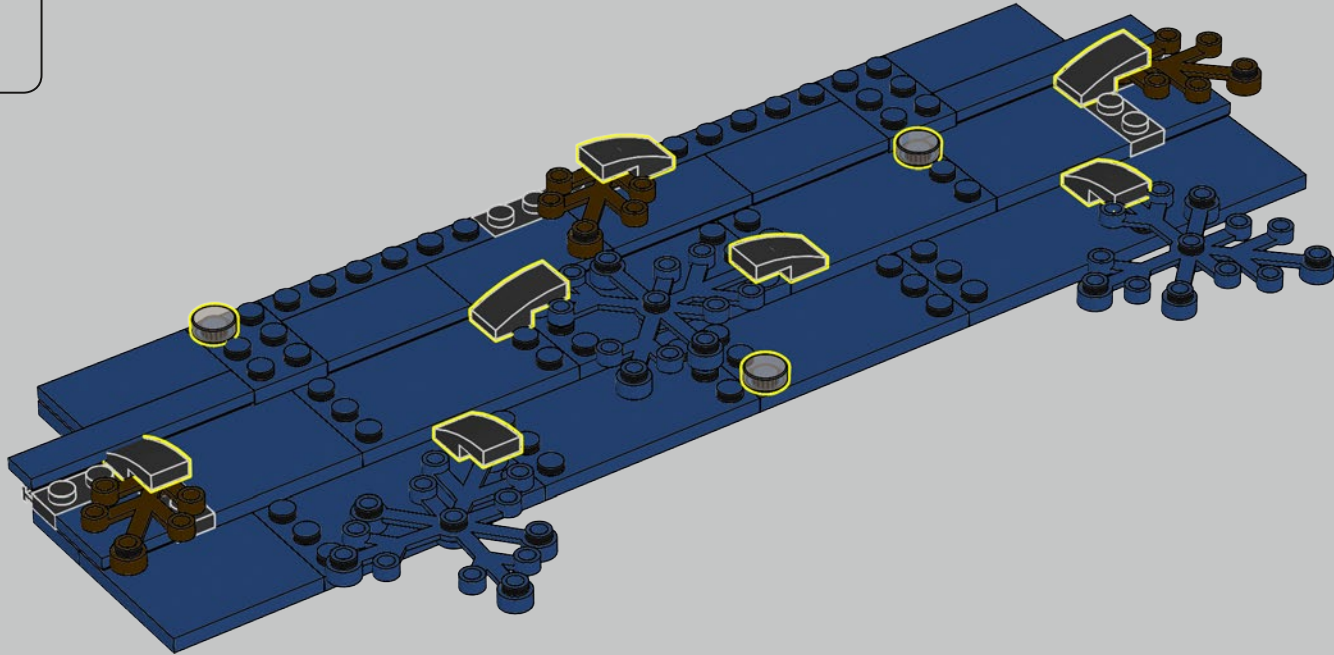



238

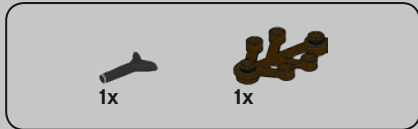
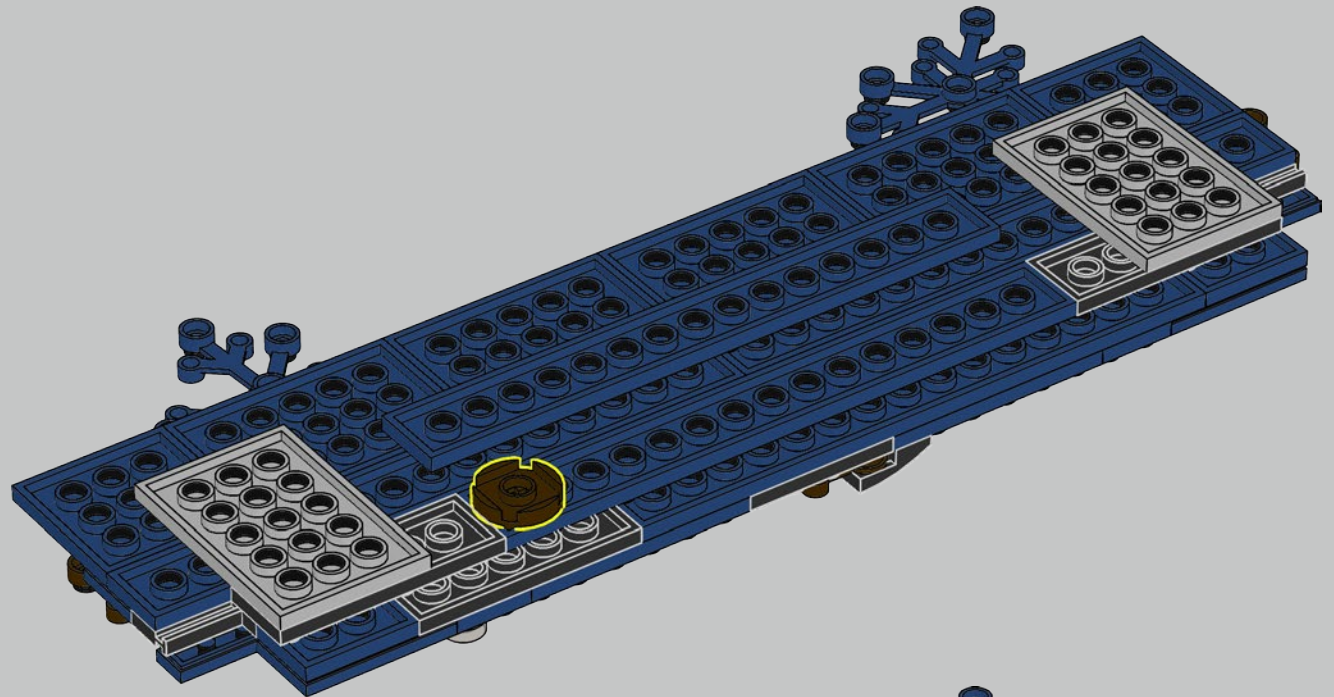

239

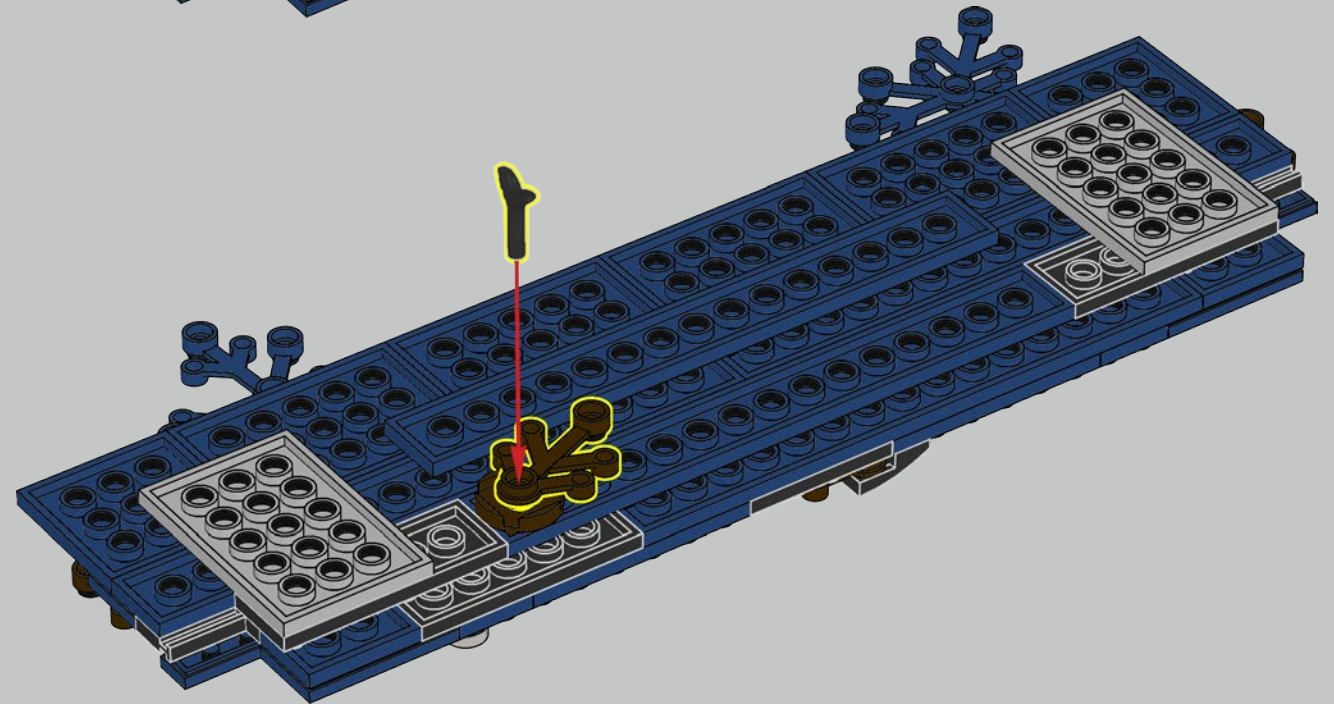

240

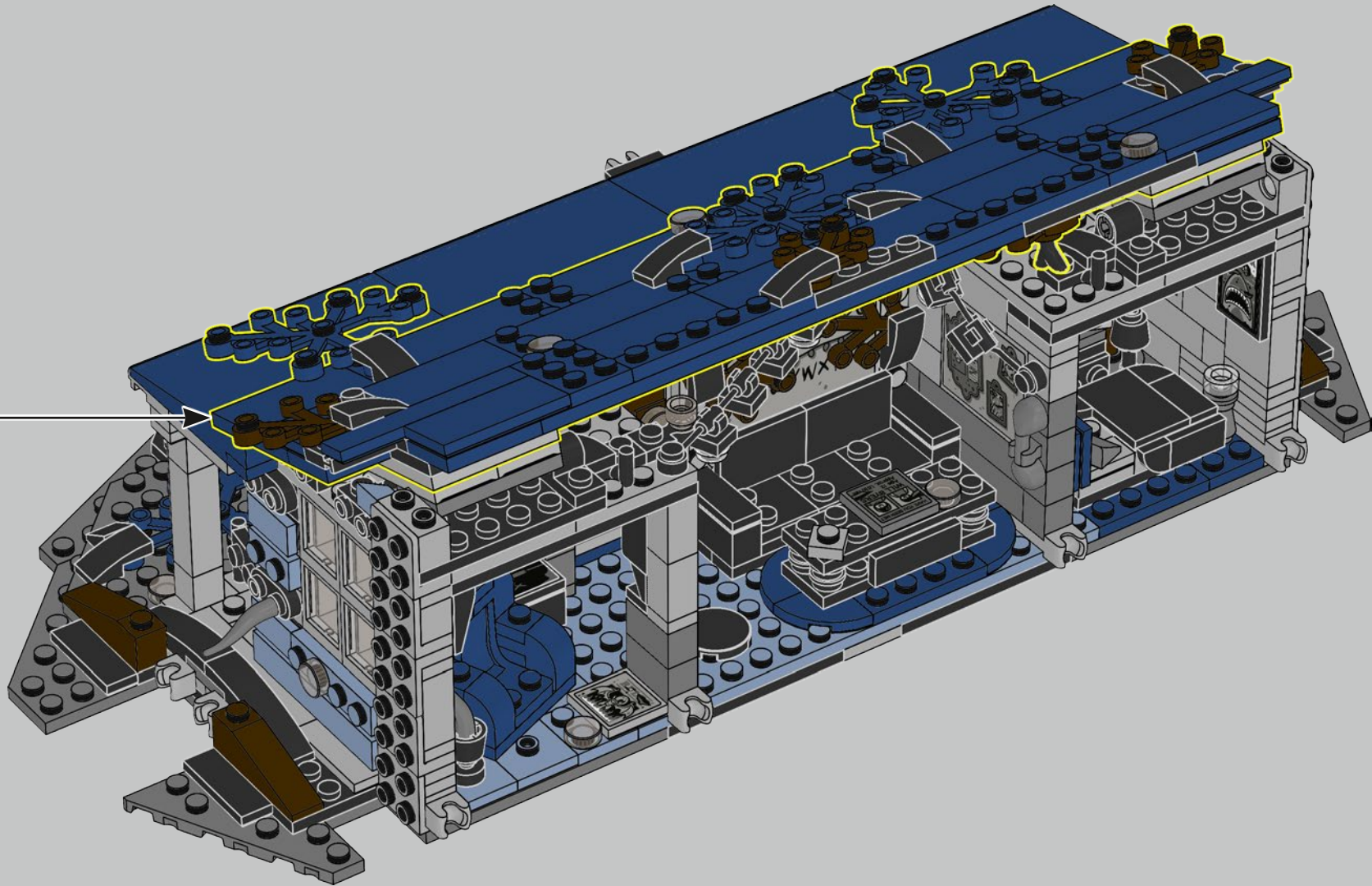

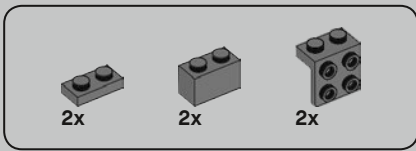

241

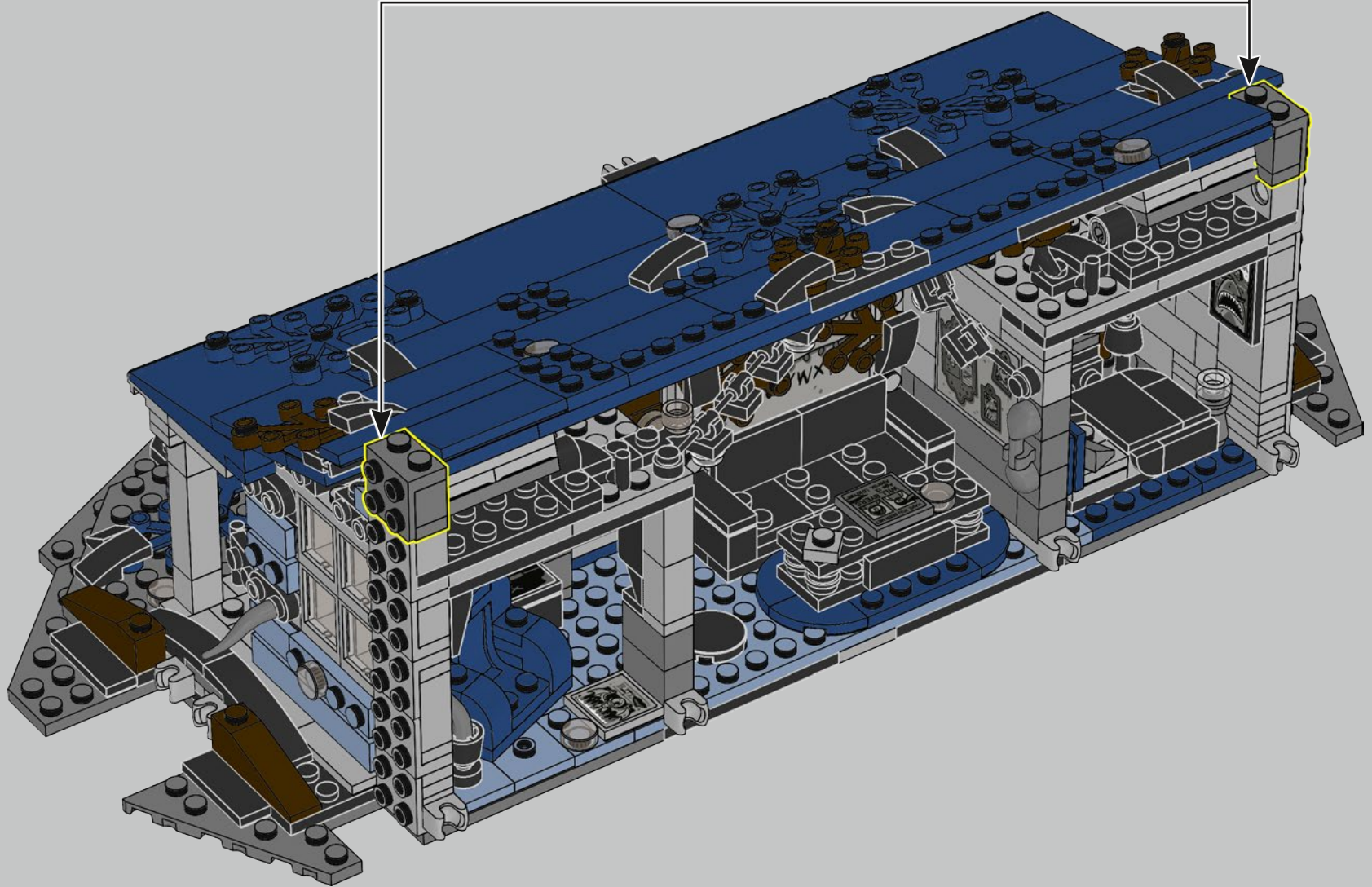
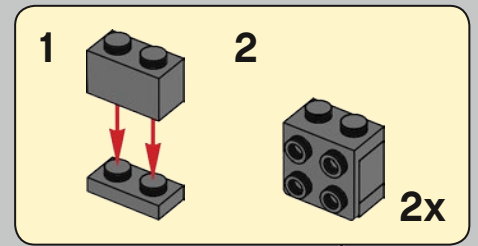

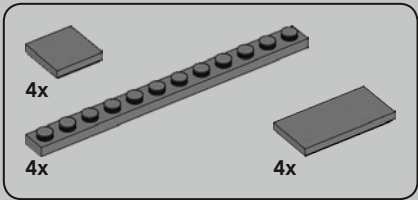

242

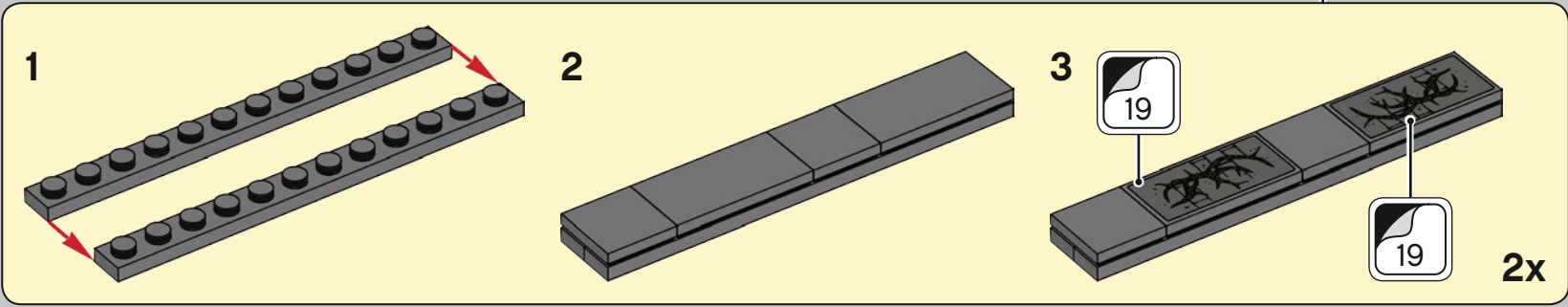
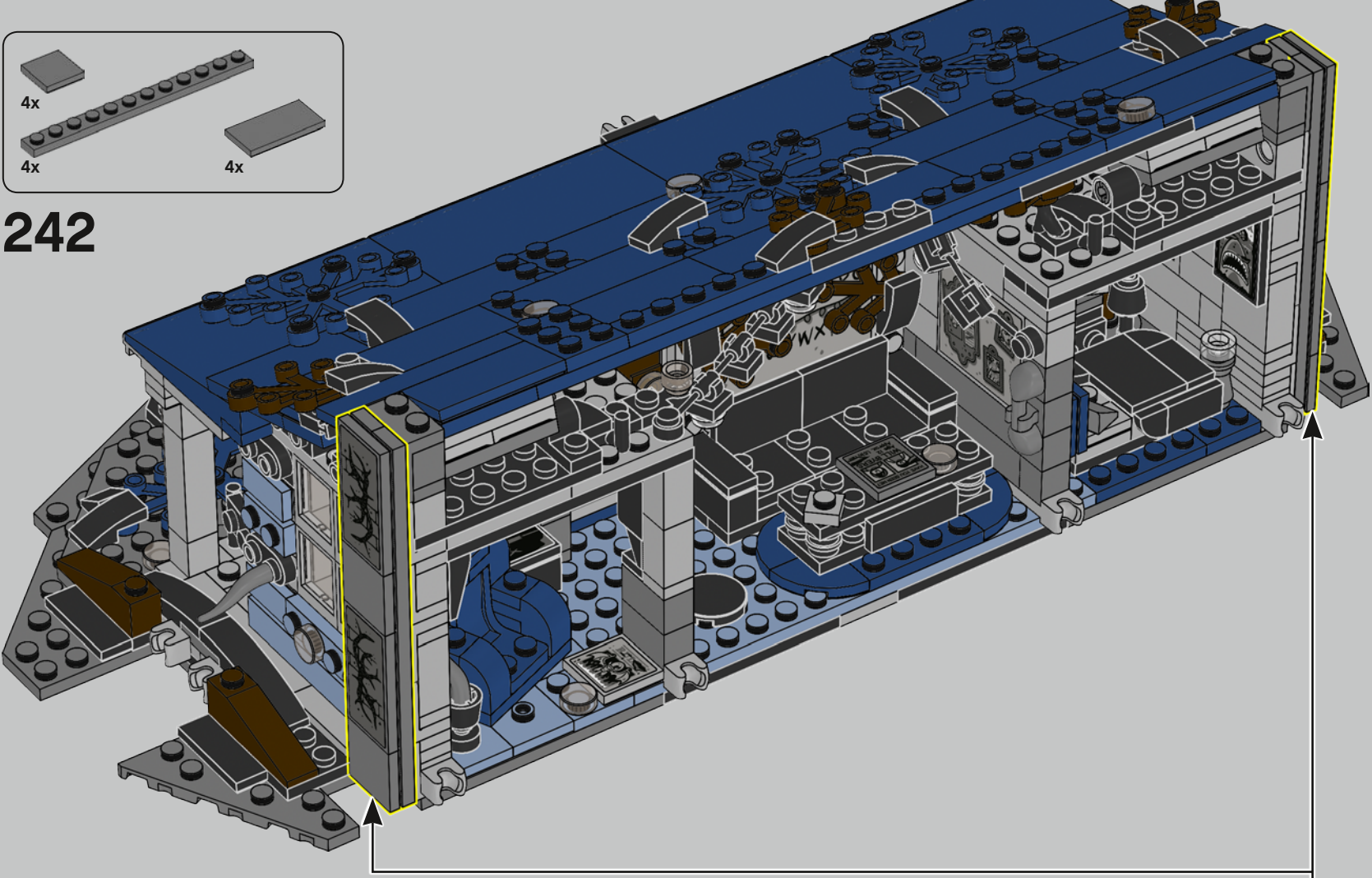



2x

243

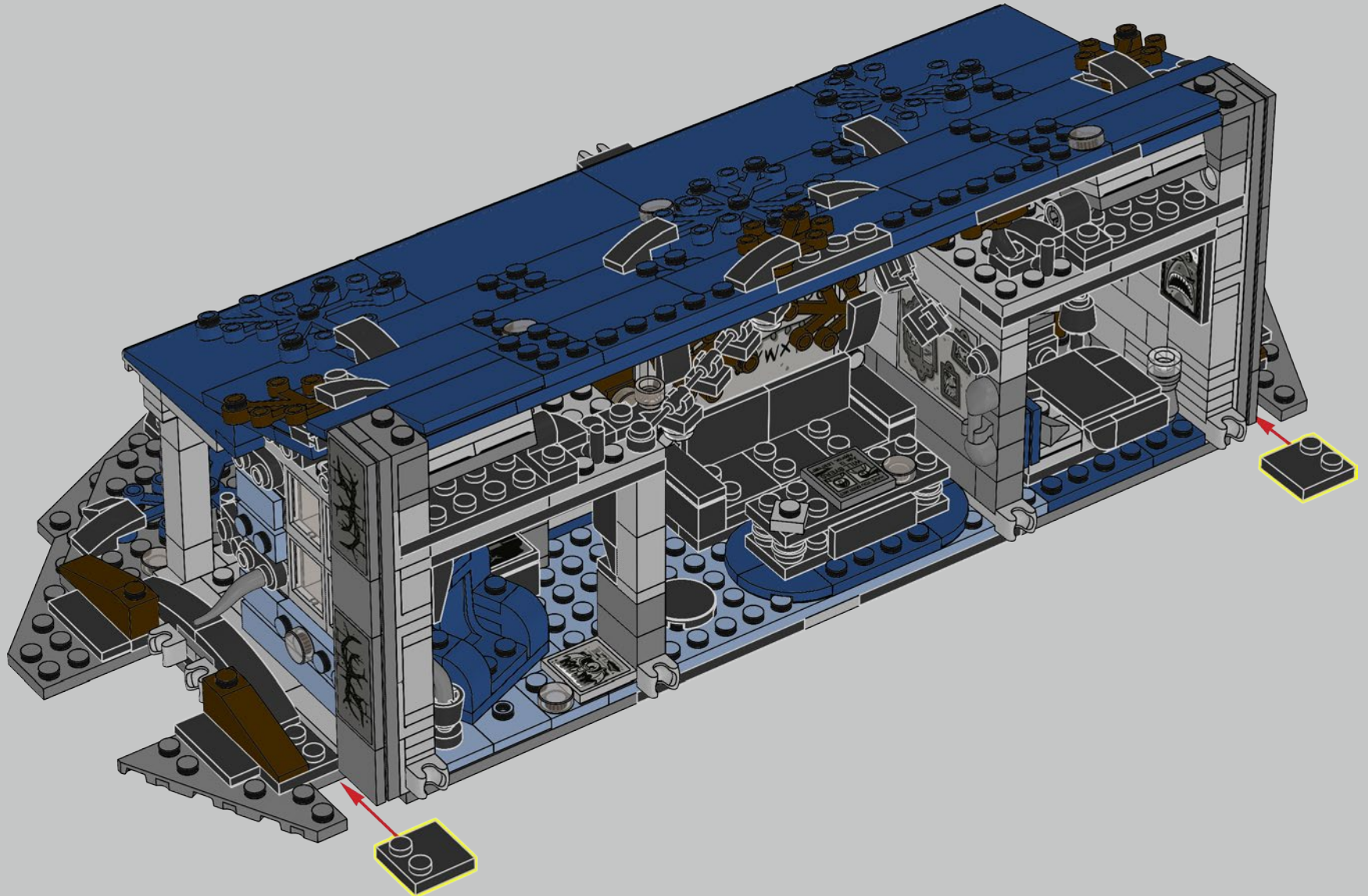



2x

244

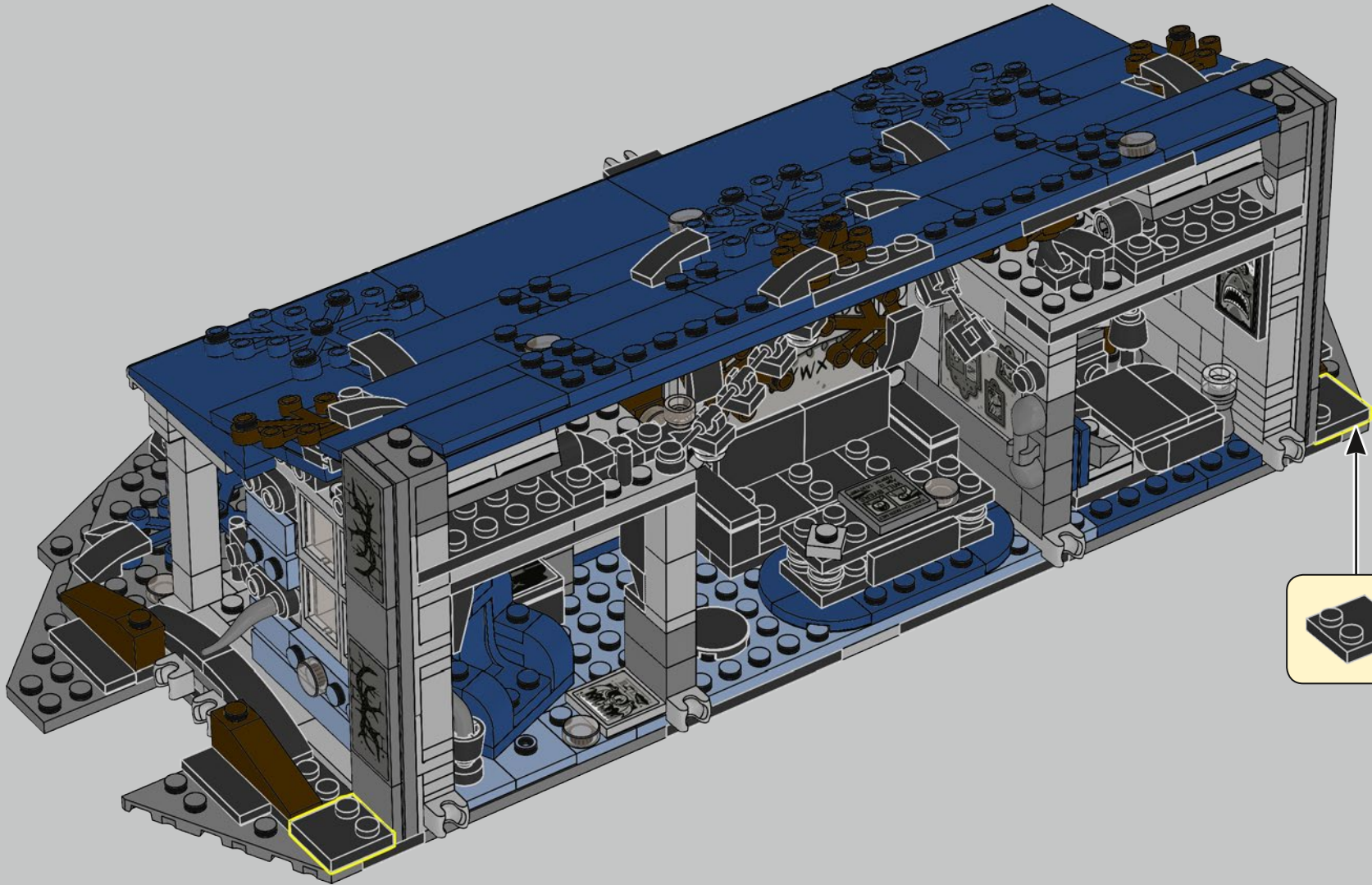

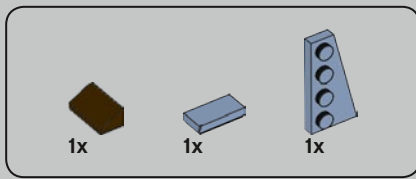

245

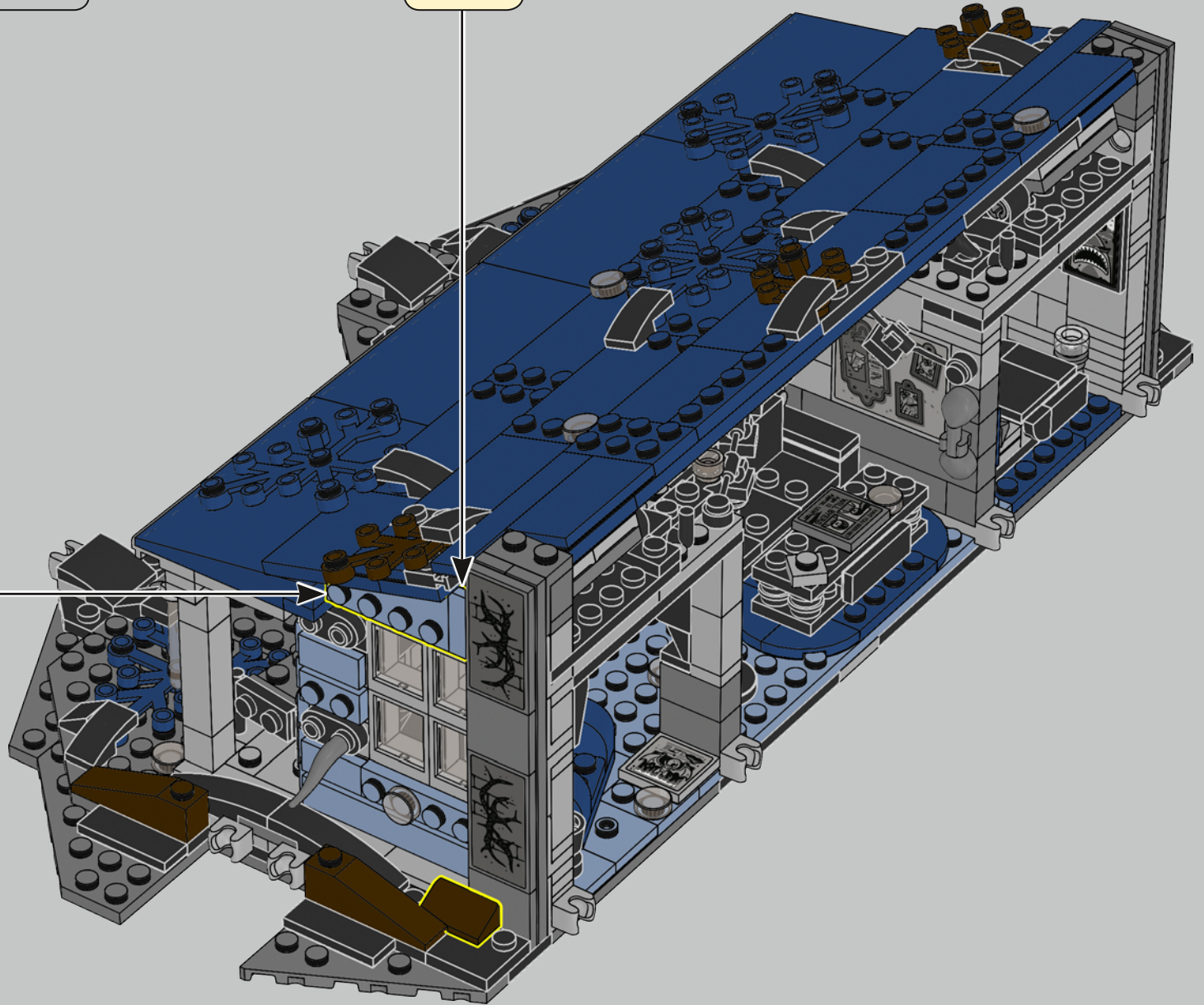
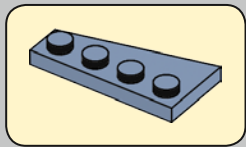
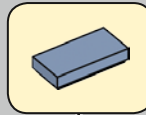

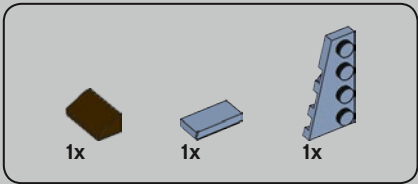

246

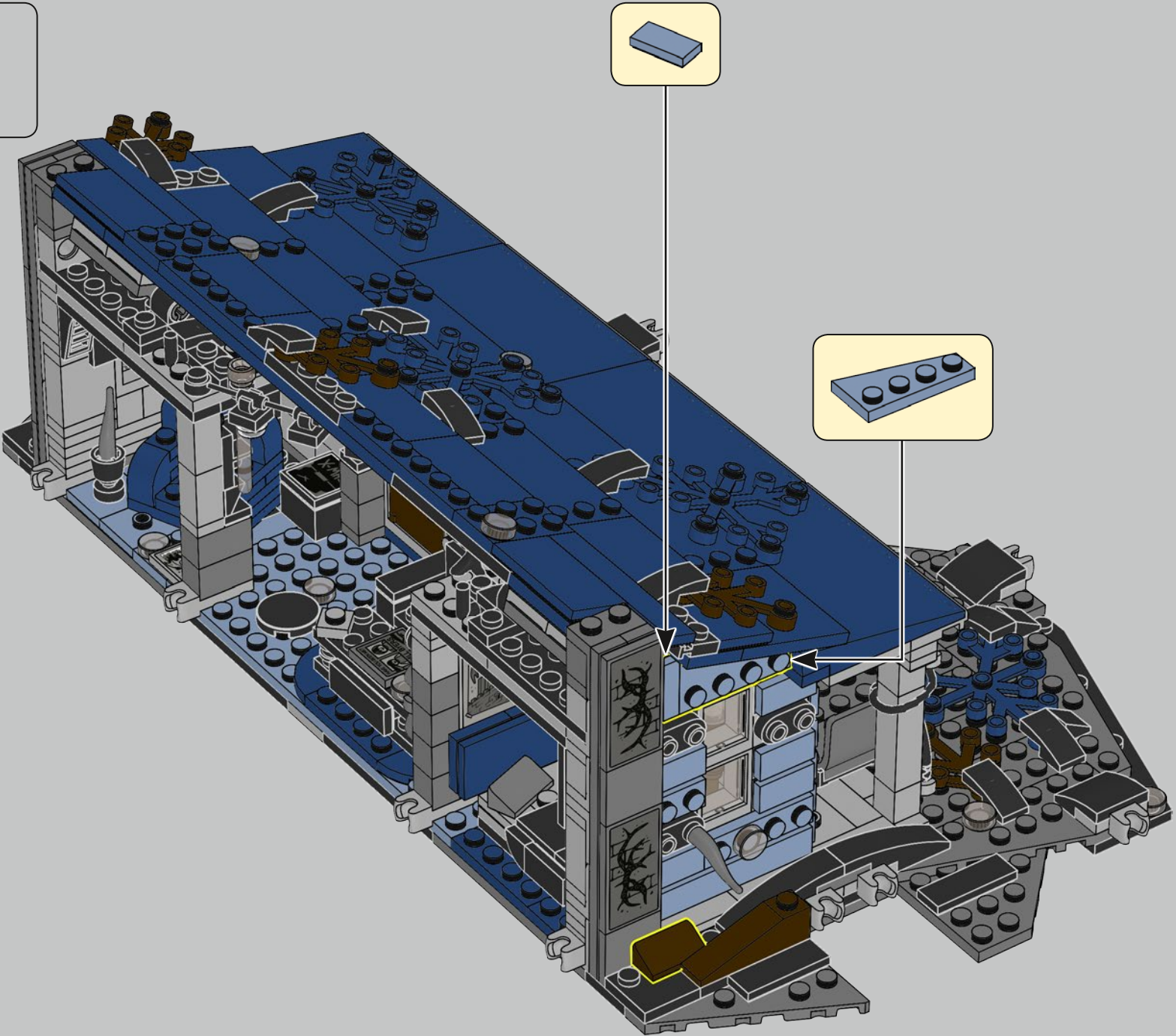

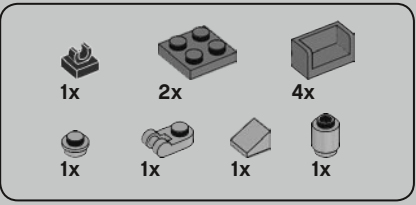

247

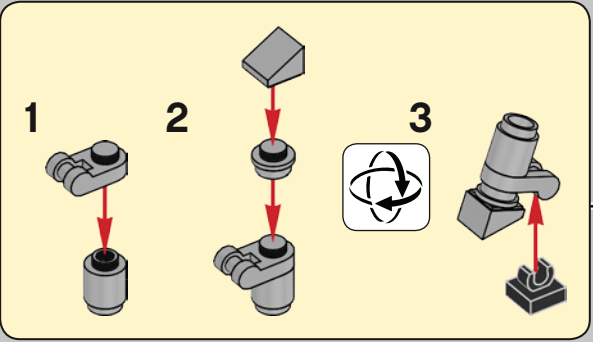
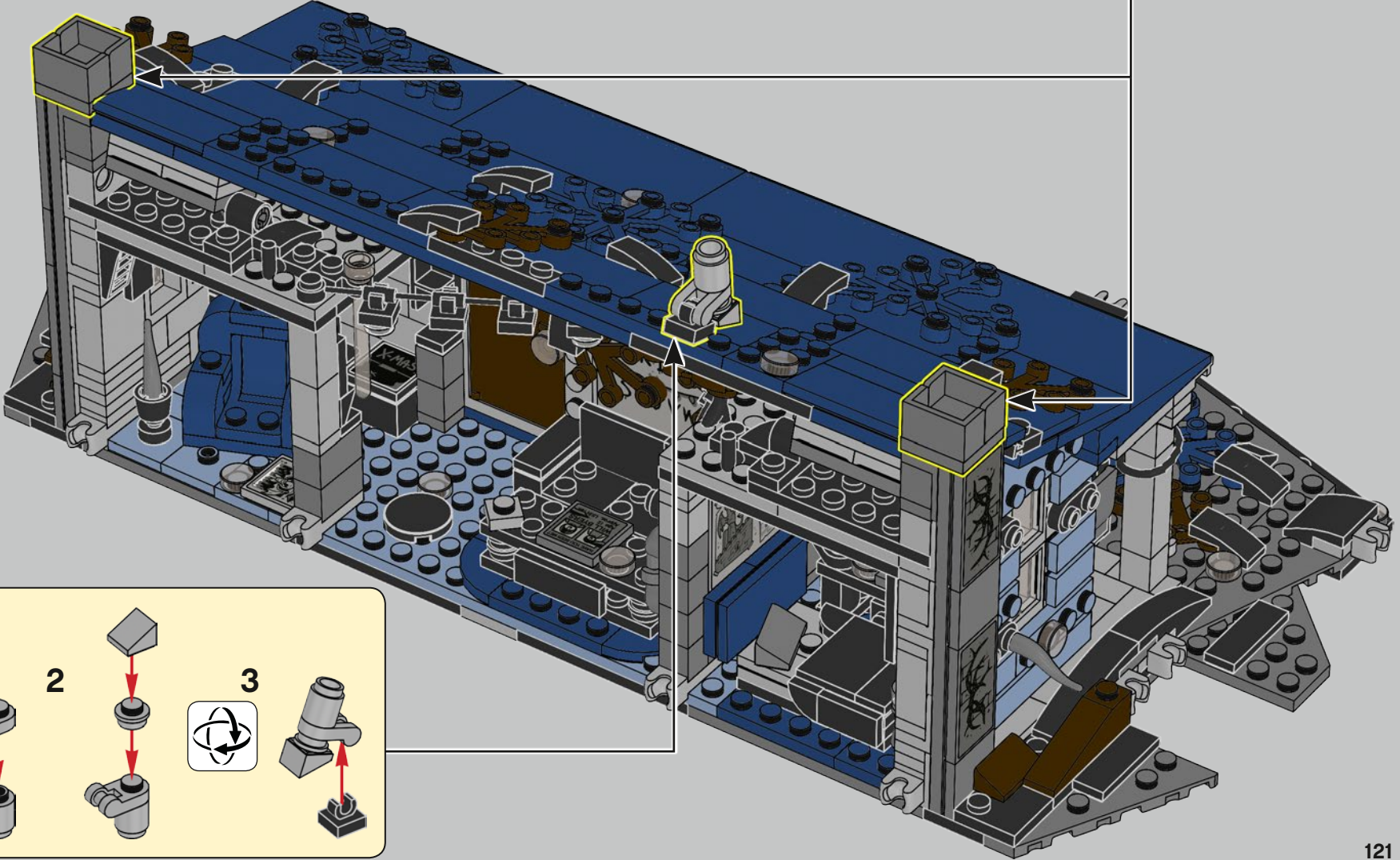
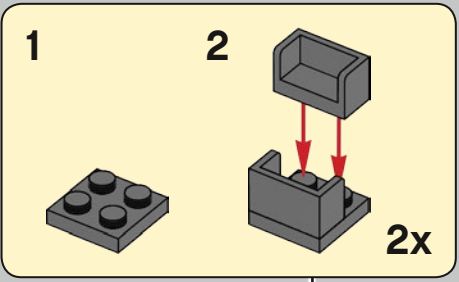

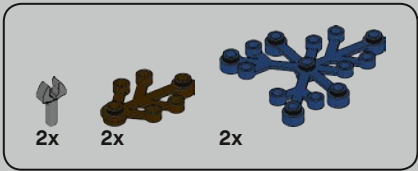

248

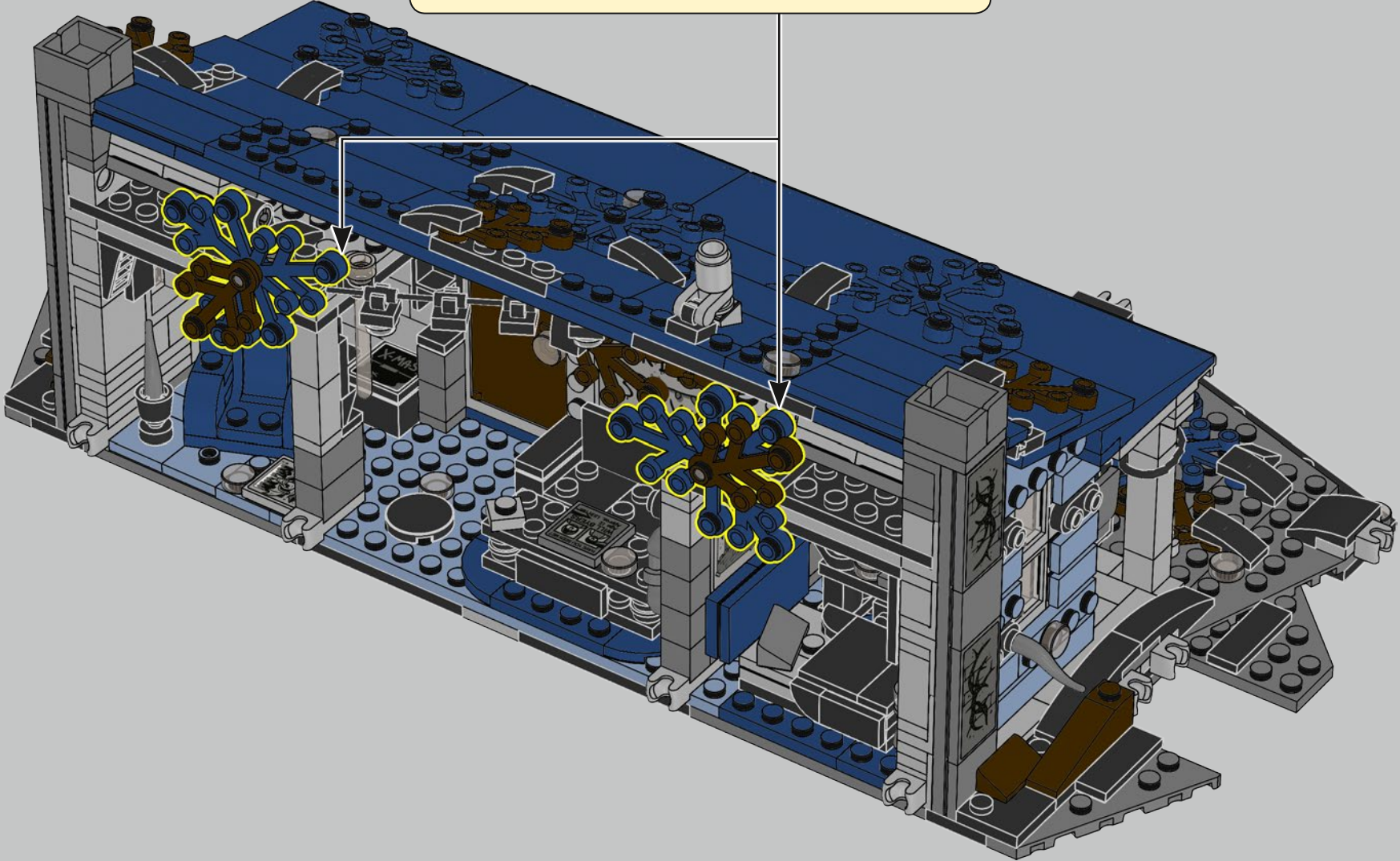
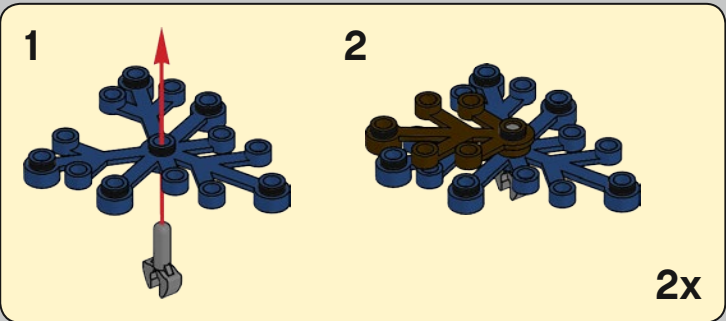

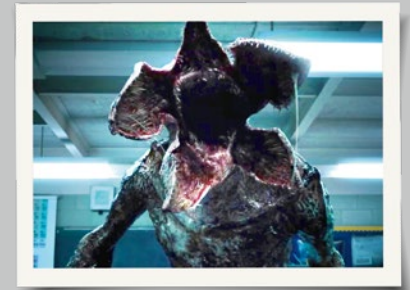
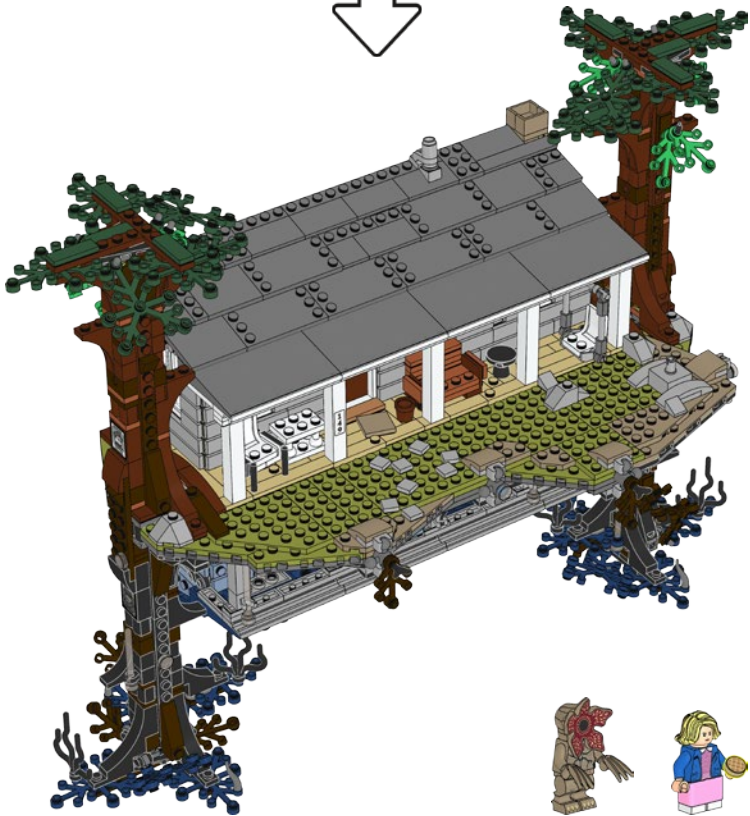
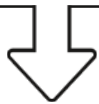

The Demogorgon is an actual *Dungeons & Dragons* monster, he is typically identified as the Prince of Demons.

Le Démogorgon est un véritable monstre tiré du jeu *Donjons et Dragons*, et est considéré comme le Prince des démons.

El Demogorgon es un verdadero monstruo de *Calabozos y Dragones* que suele identificarse con el Príncipe de los Demonios.

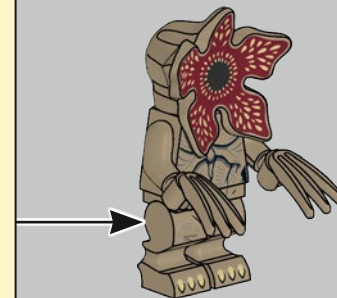
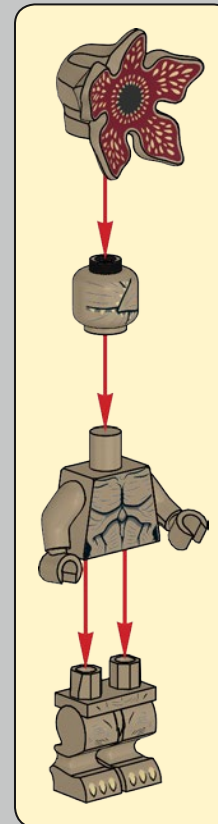



Eleven's iconic pink dress and blonde wig are homage to E.T.'s disguise in the movie *E.T. the Extra-Terrestrial* (1982).

La robe rose emblématique et la perruque blonde de Onze font référence au déguisement de E.T. dans le film *E.T. l'extra-terrestre* (1982).

El inconfundible vestido rosa y la peluca rubia de Once son un homenaje al disfraz que usa E.T. en la película *E.T., el Extraterrestre* (1982).



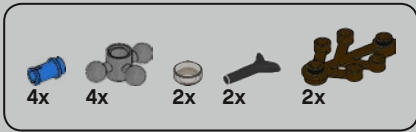

249

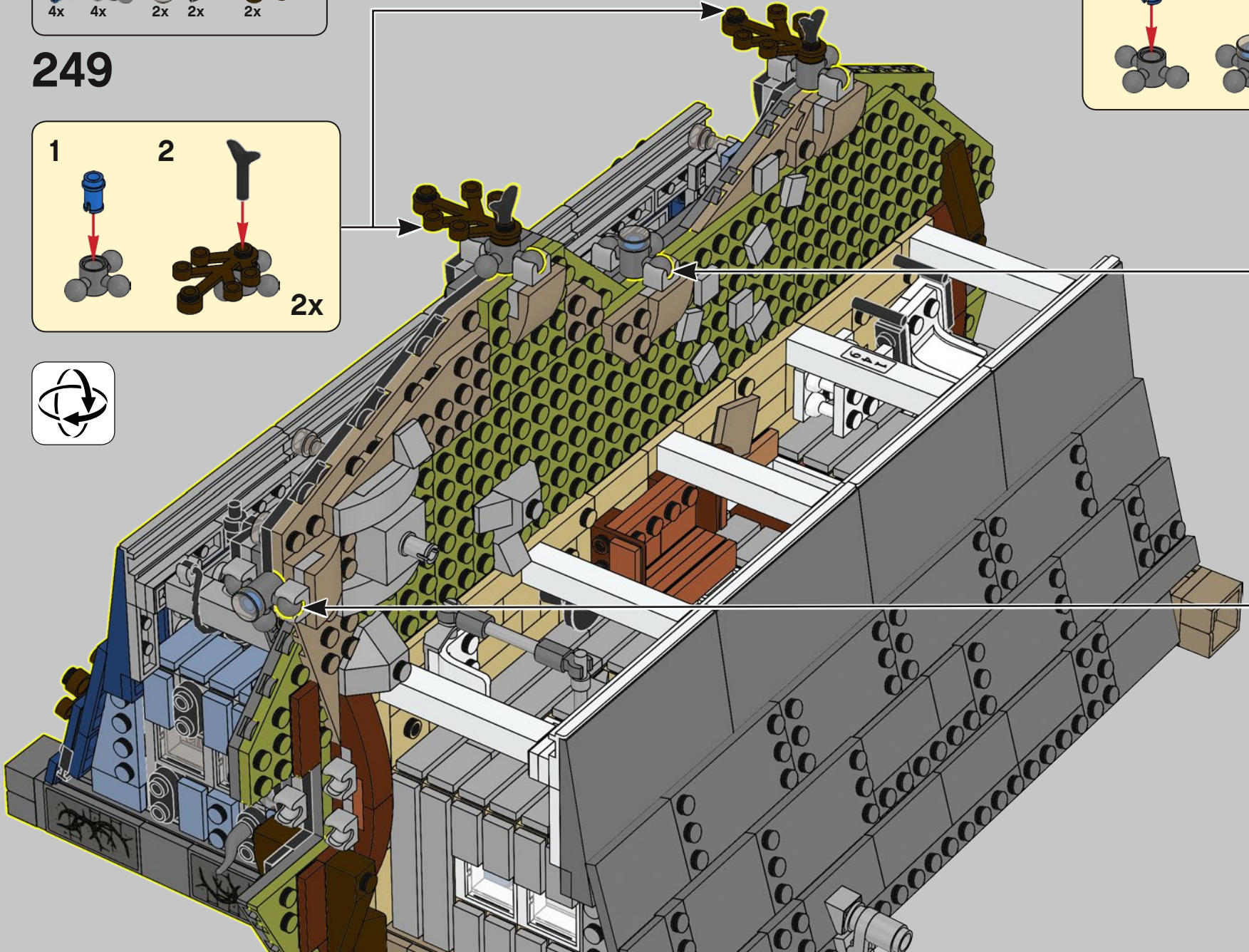
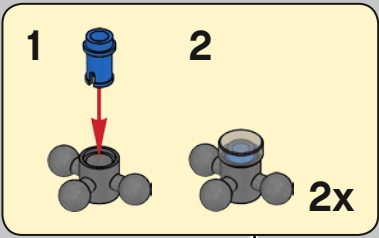
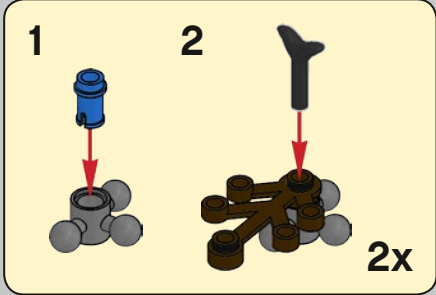

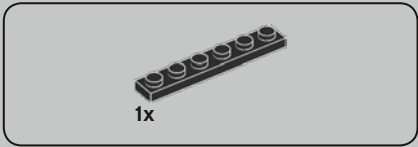

250

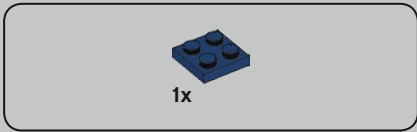
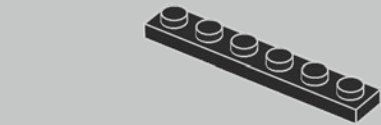

251

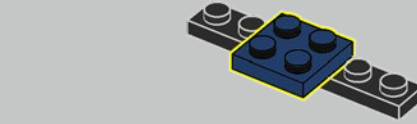

252

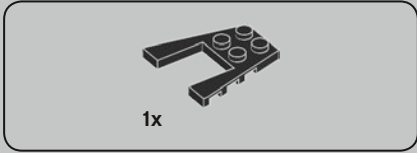
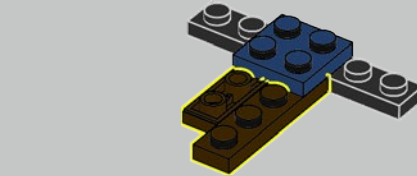

253

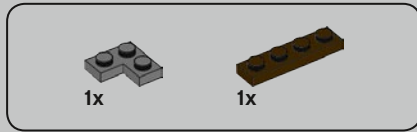
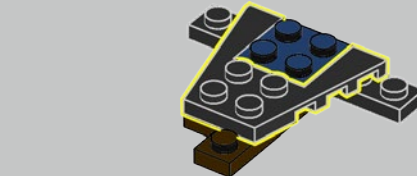

254

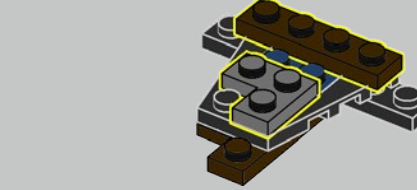

255

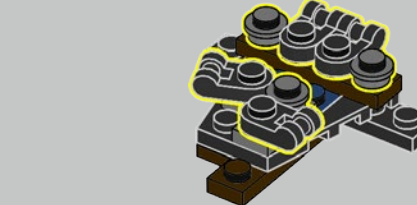

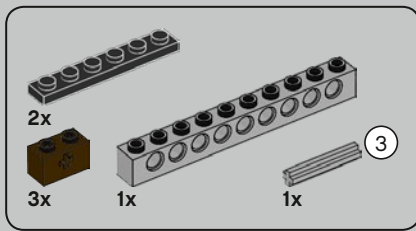

256

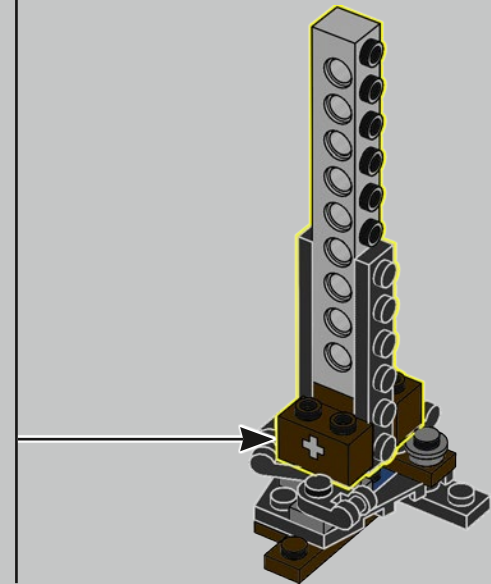
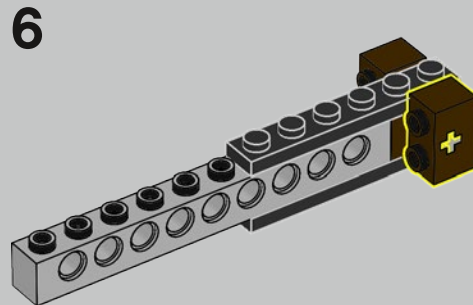
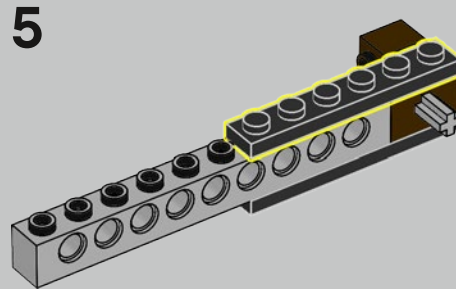
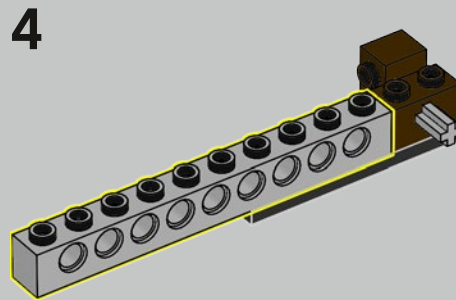
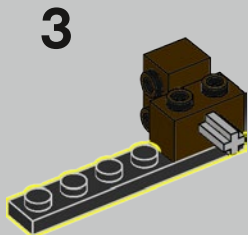
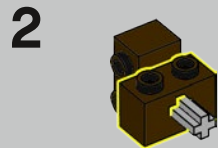
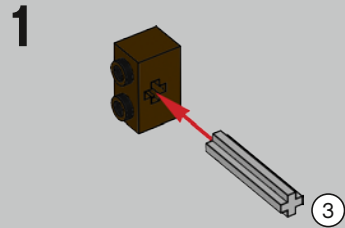

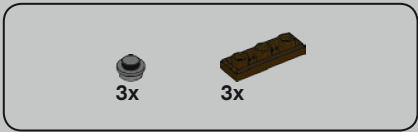

257

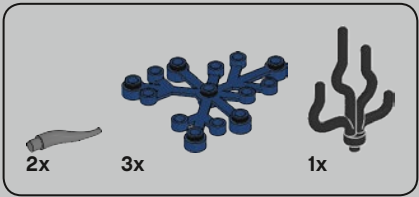
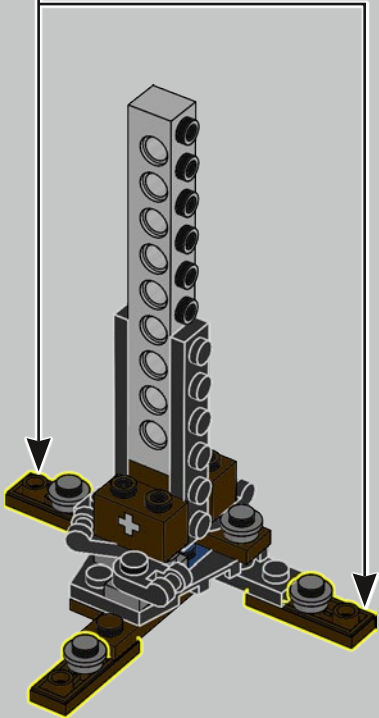
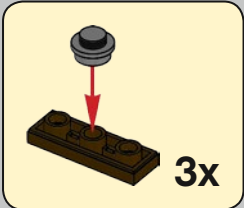

258

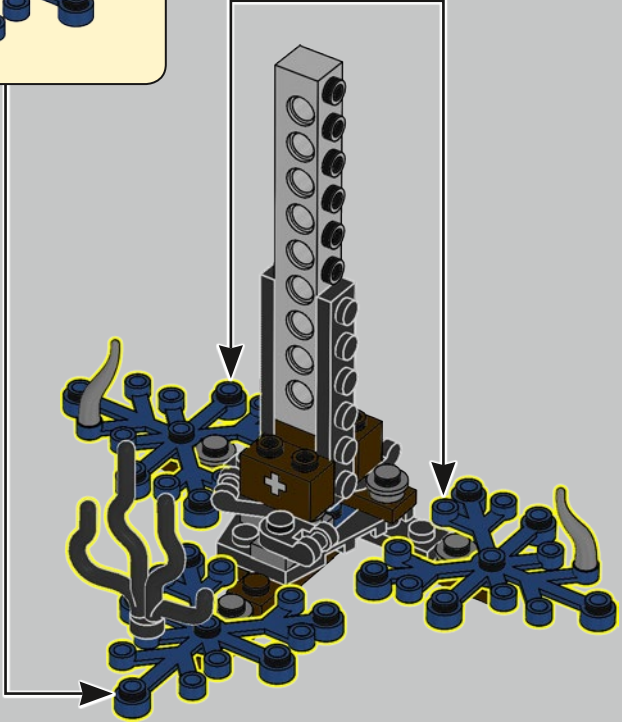
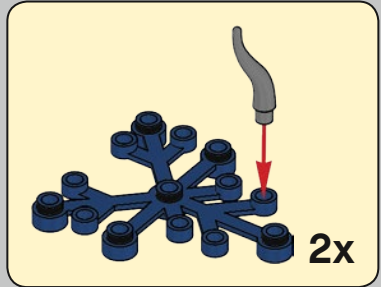
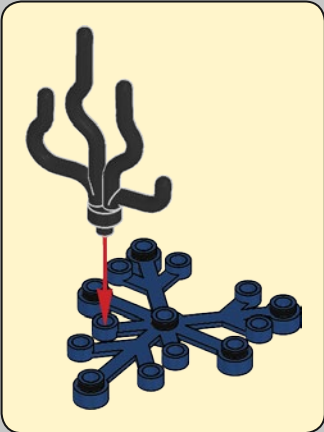

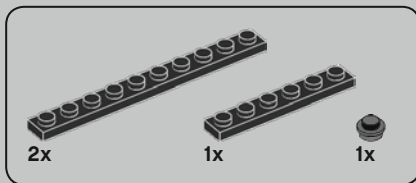

259

1

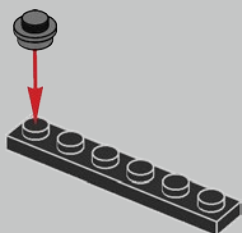

2

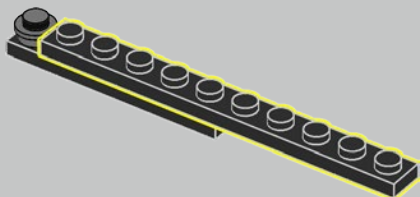

3

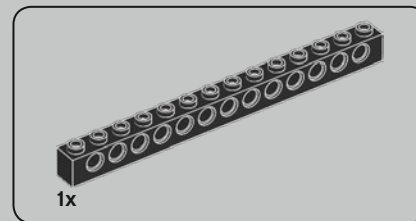
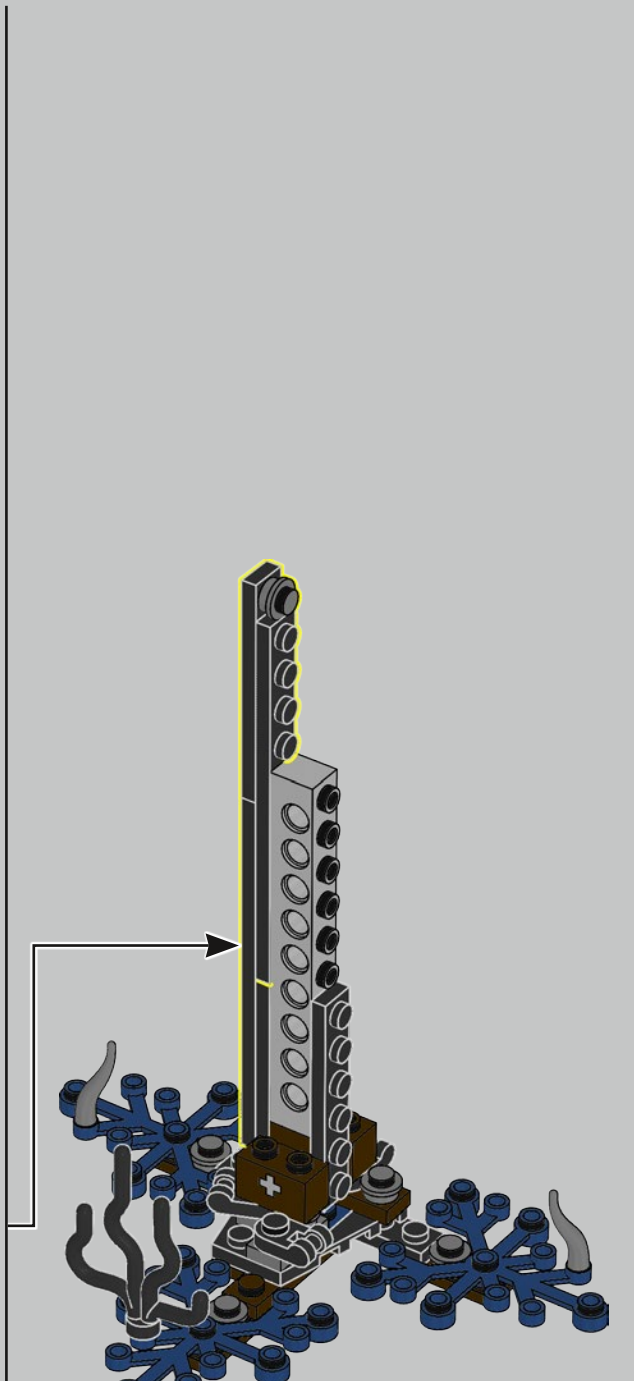
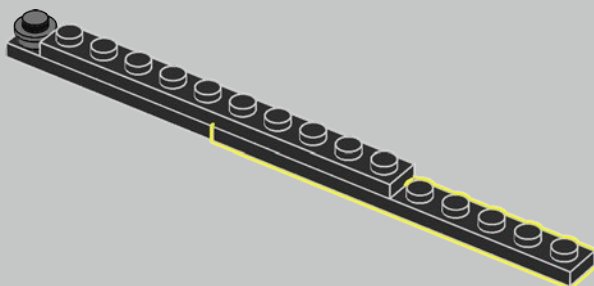

260

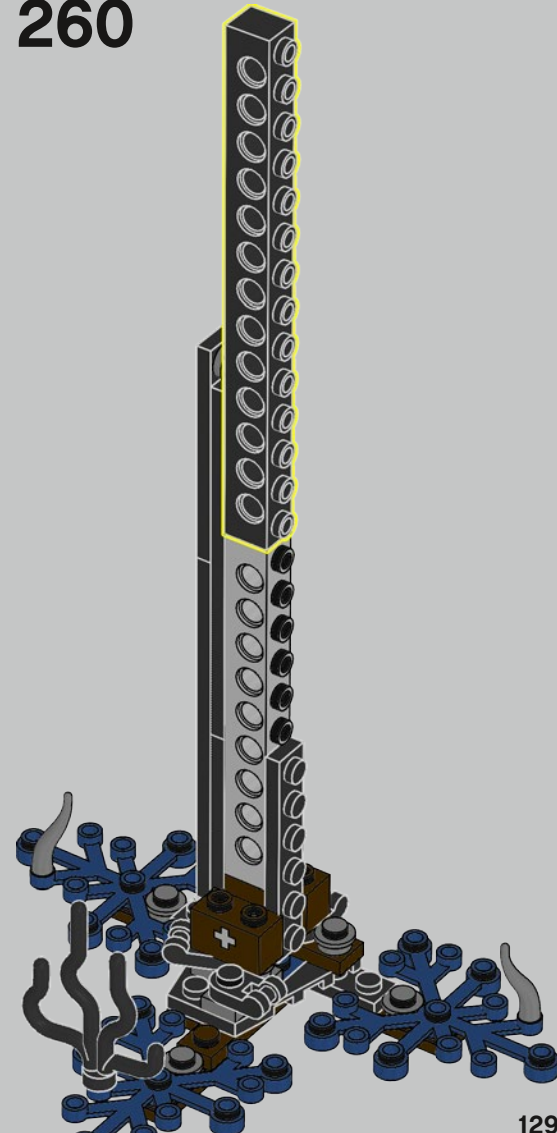

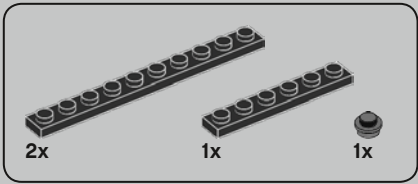

261

1

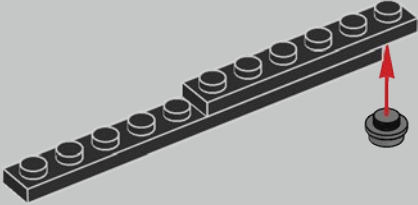

2

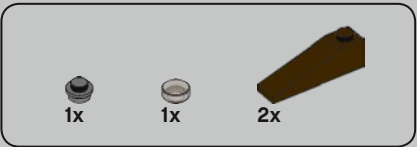
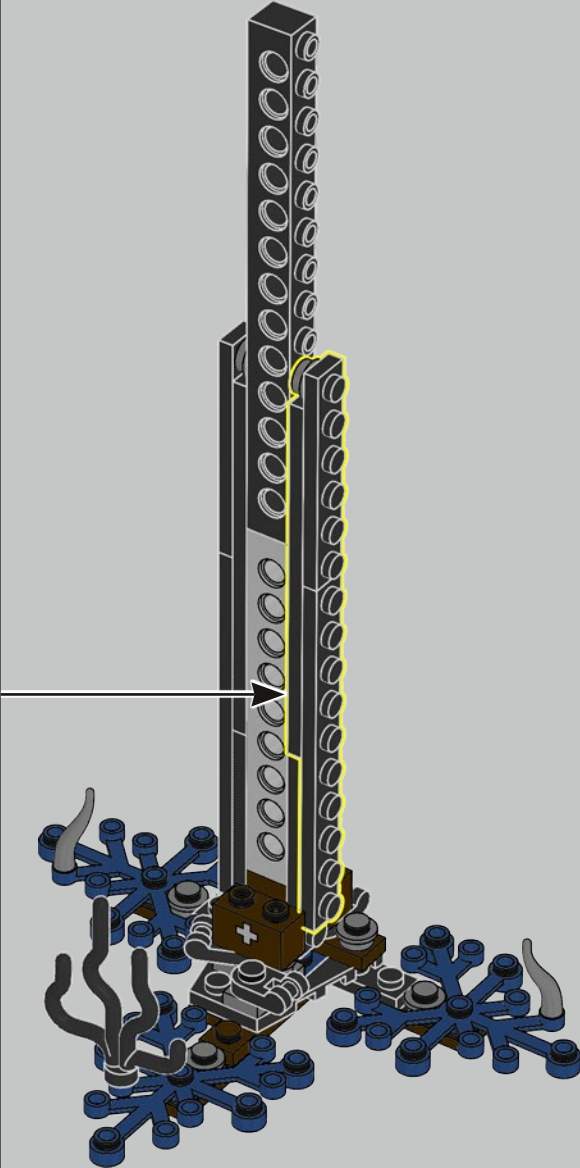
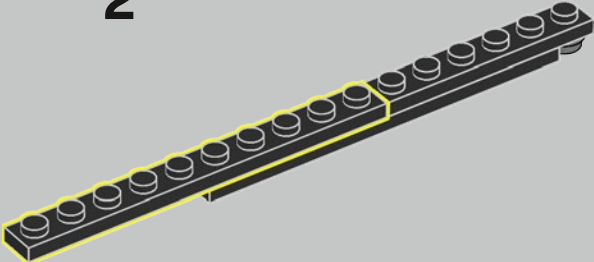

262

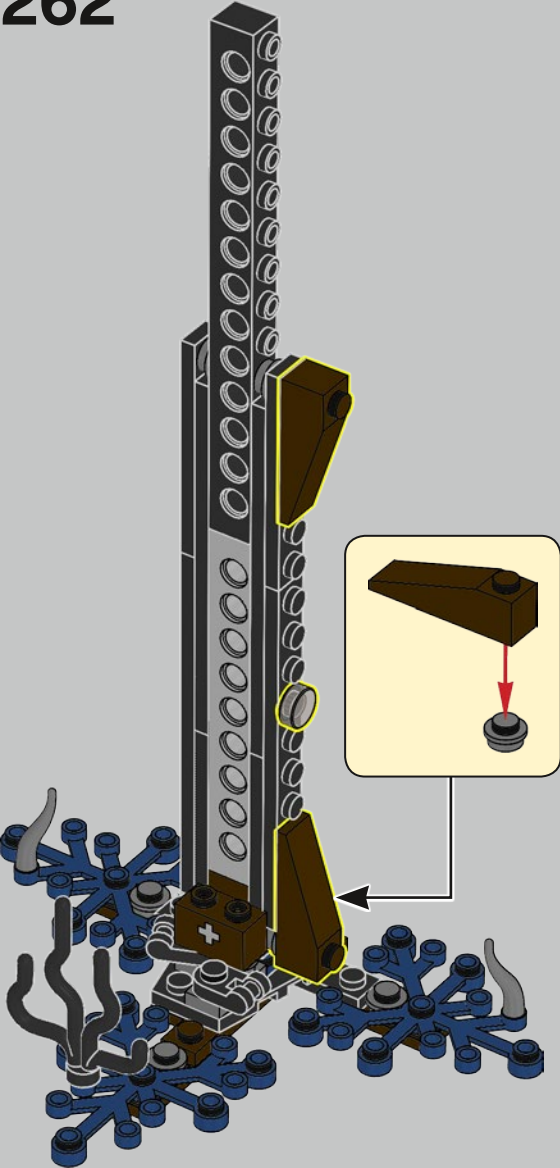

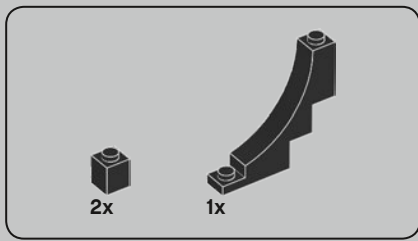

263

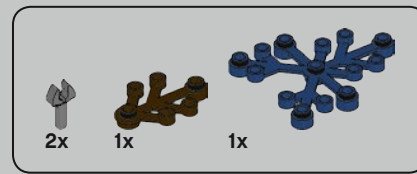
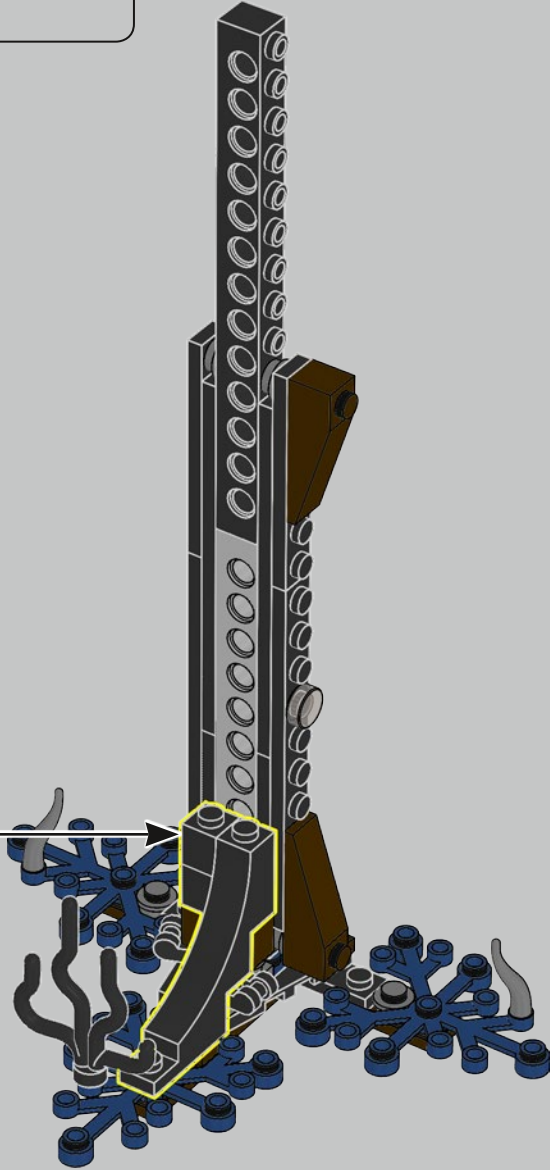
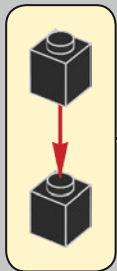

264

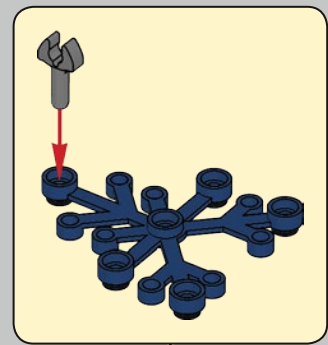
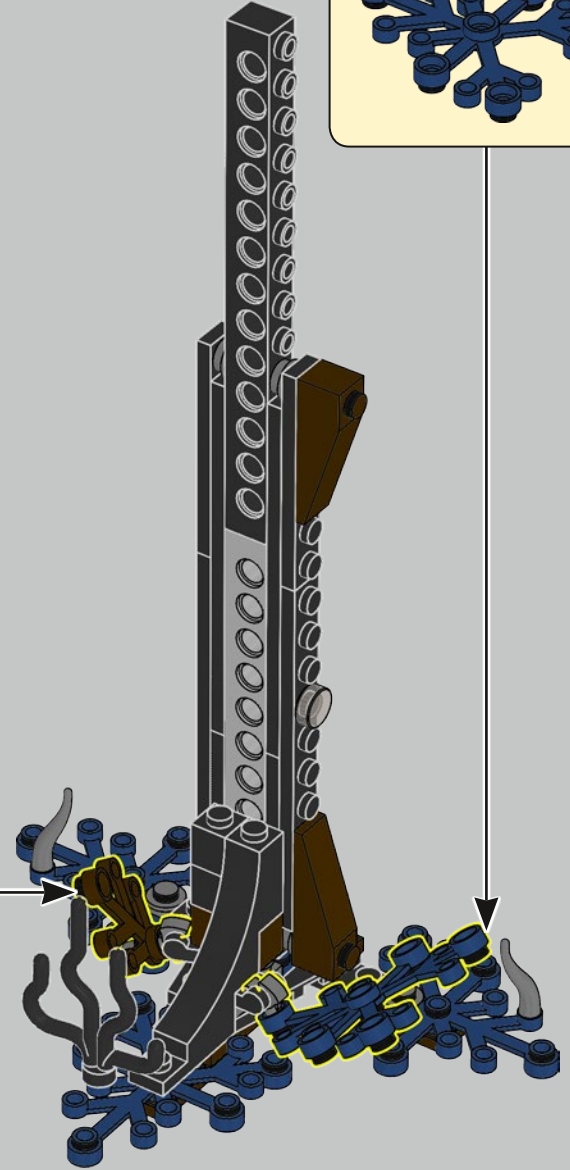
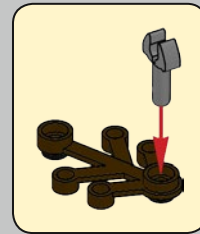

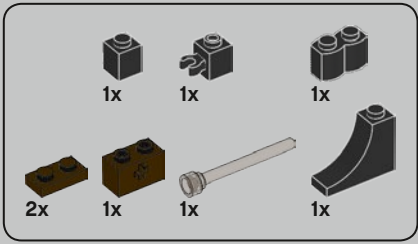

265

1

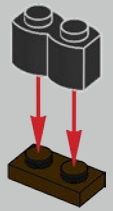

2

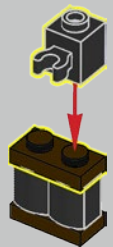

3

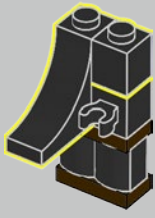

4

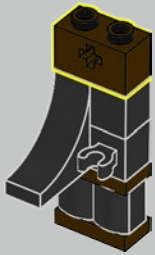

5

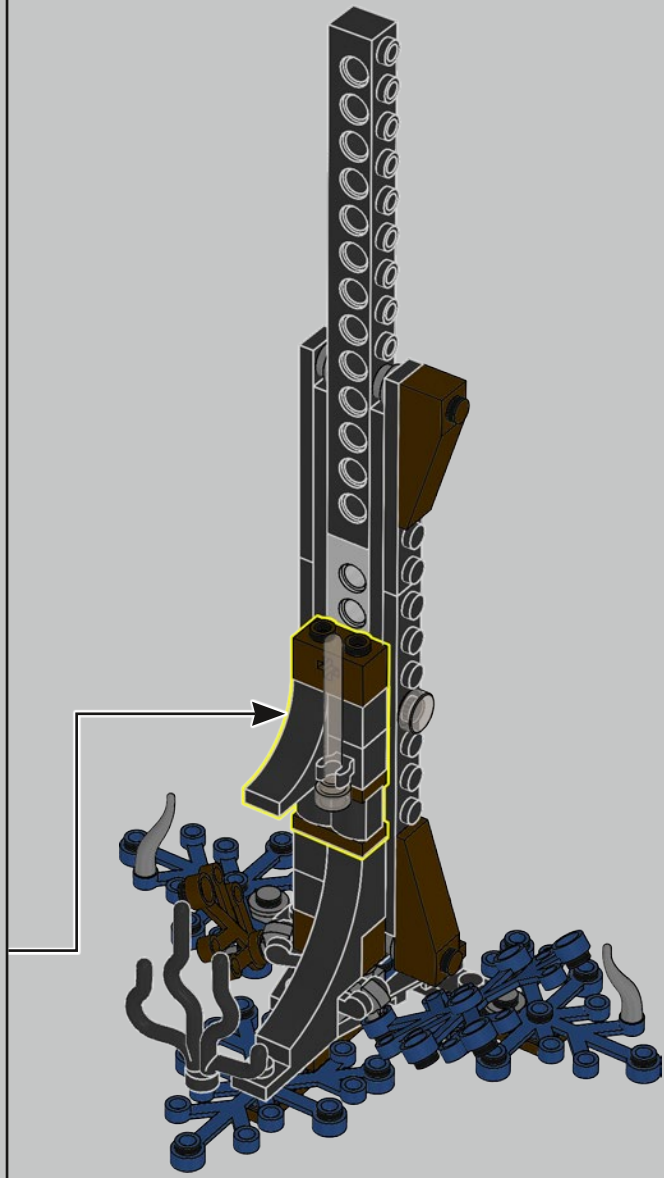
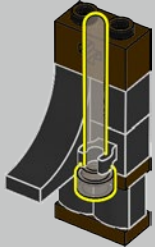



266

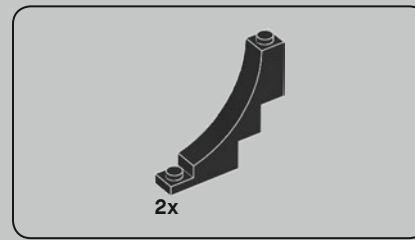
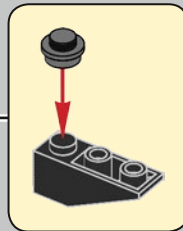
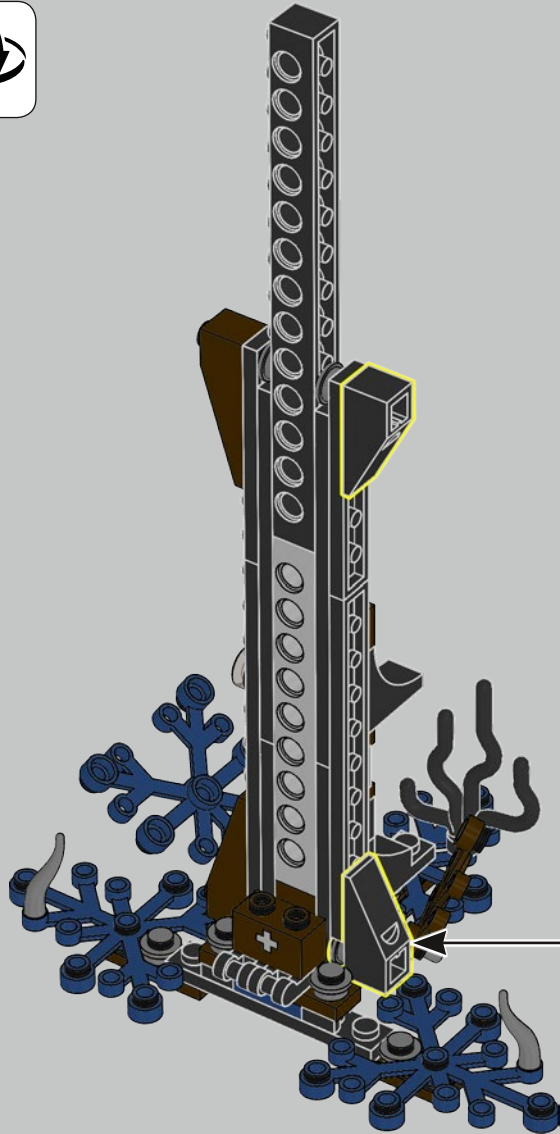

267

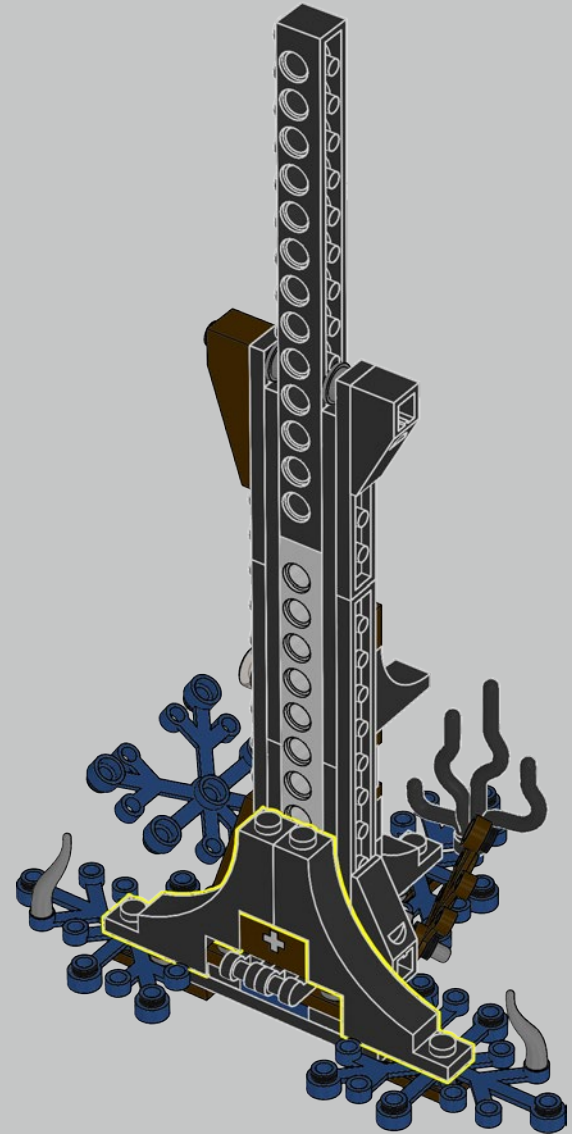

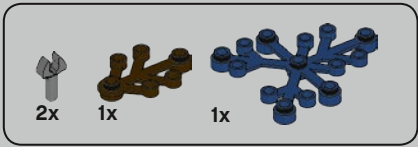

268

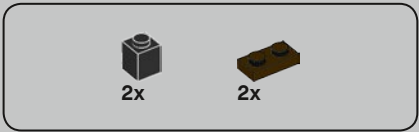
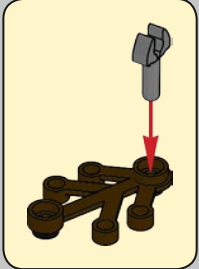
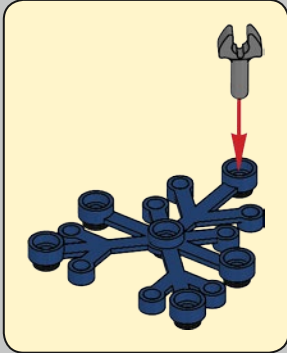
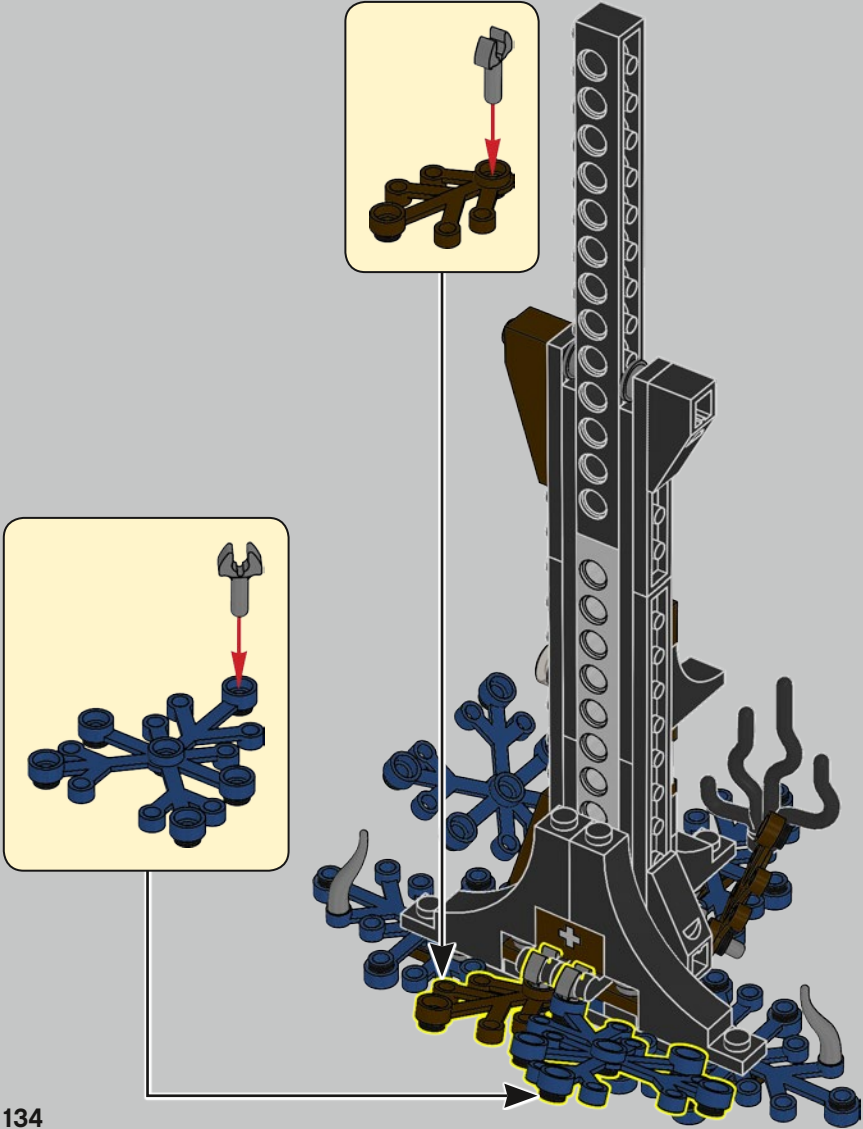

269

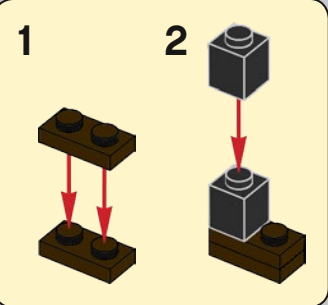
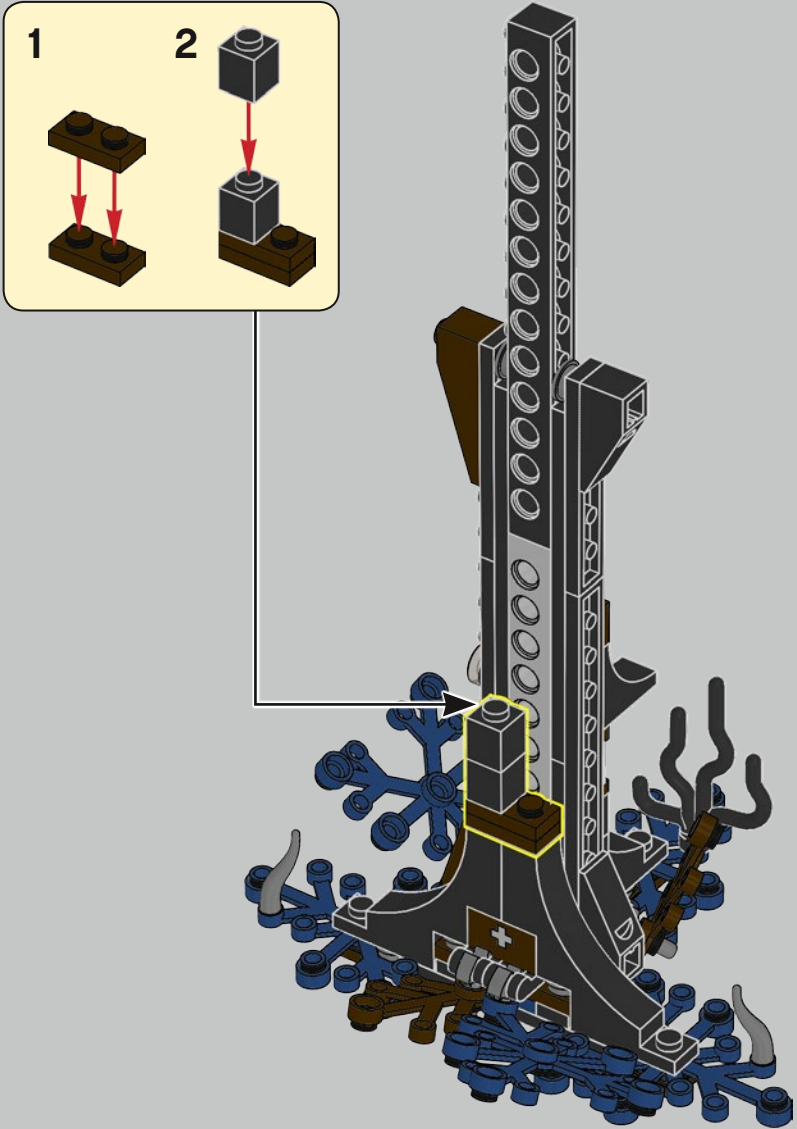

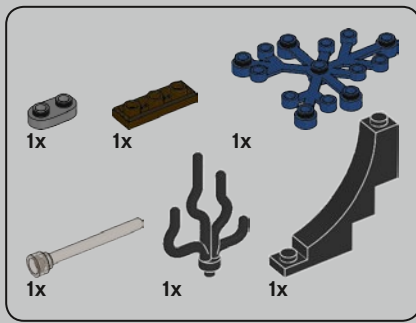

270

1

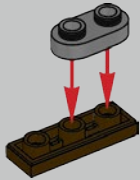

2



3

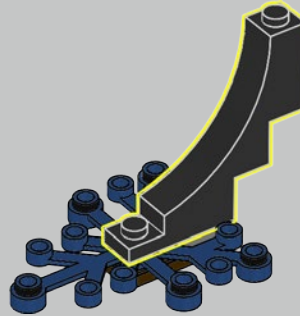

4

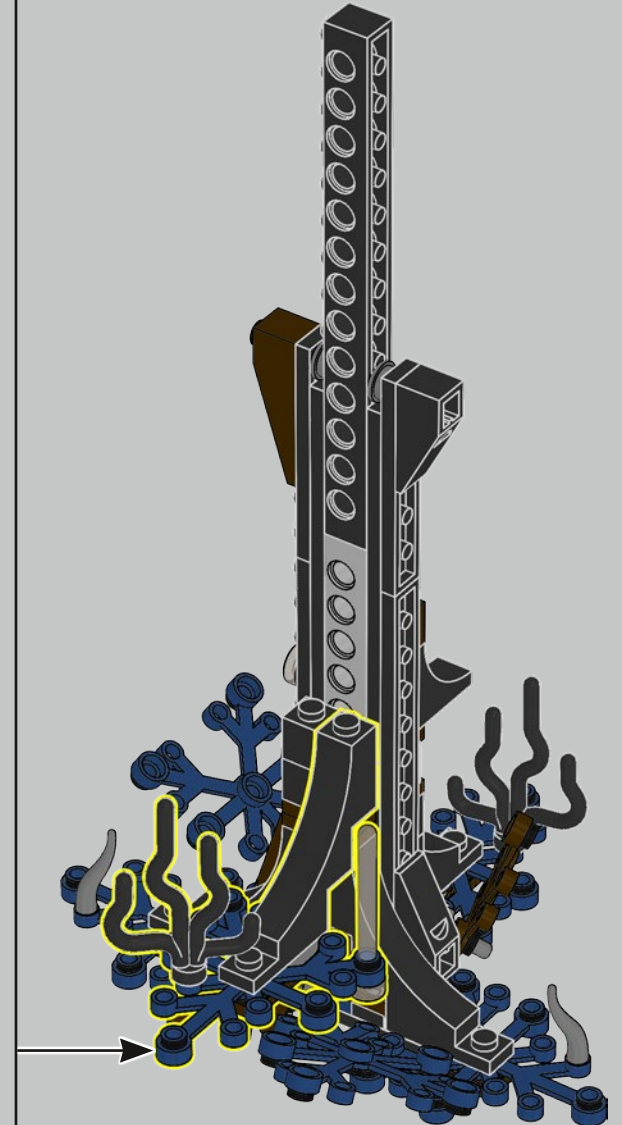
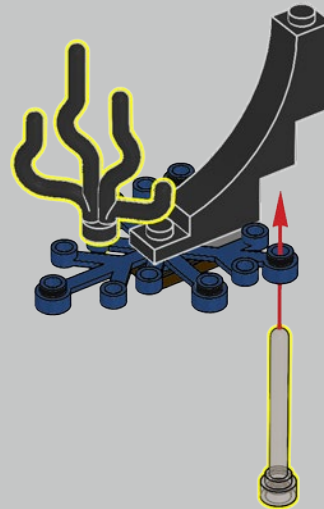

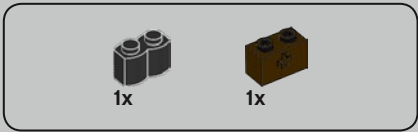

271

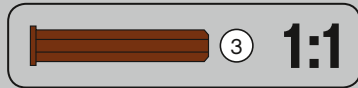
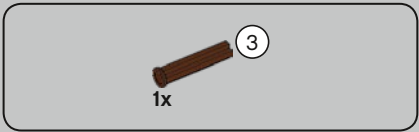
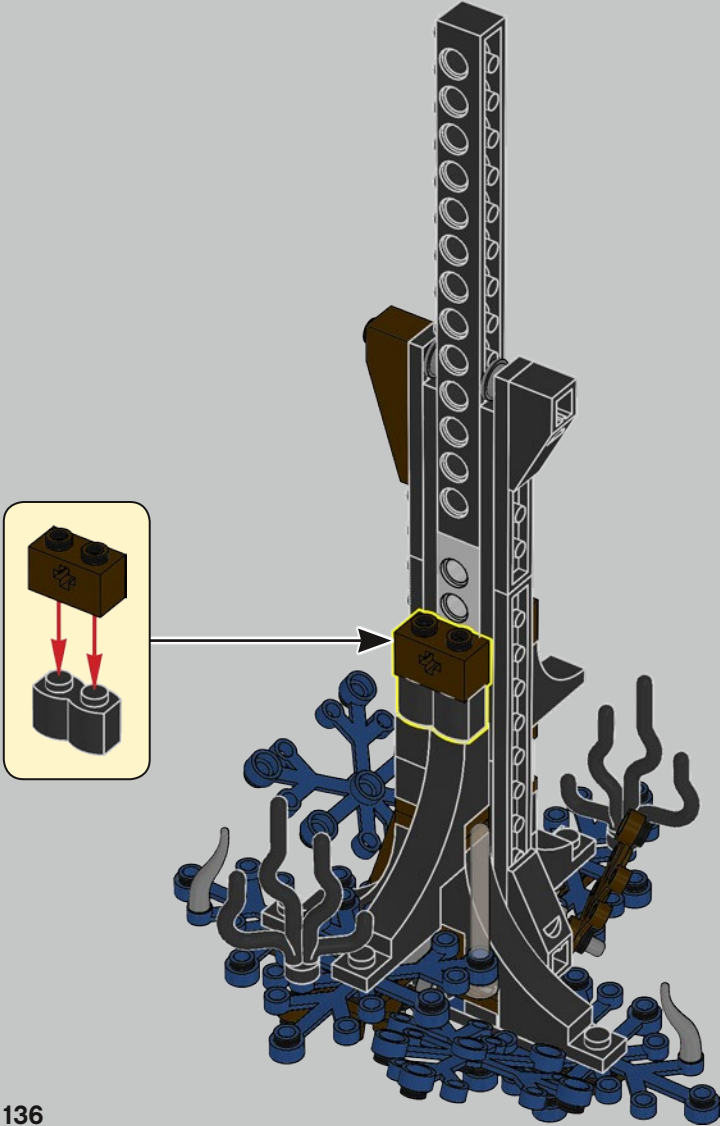

272

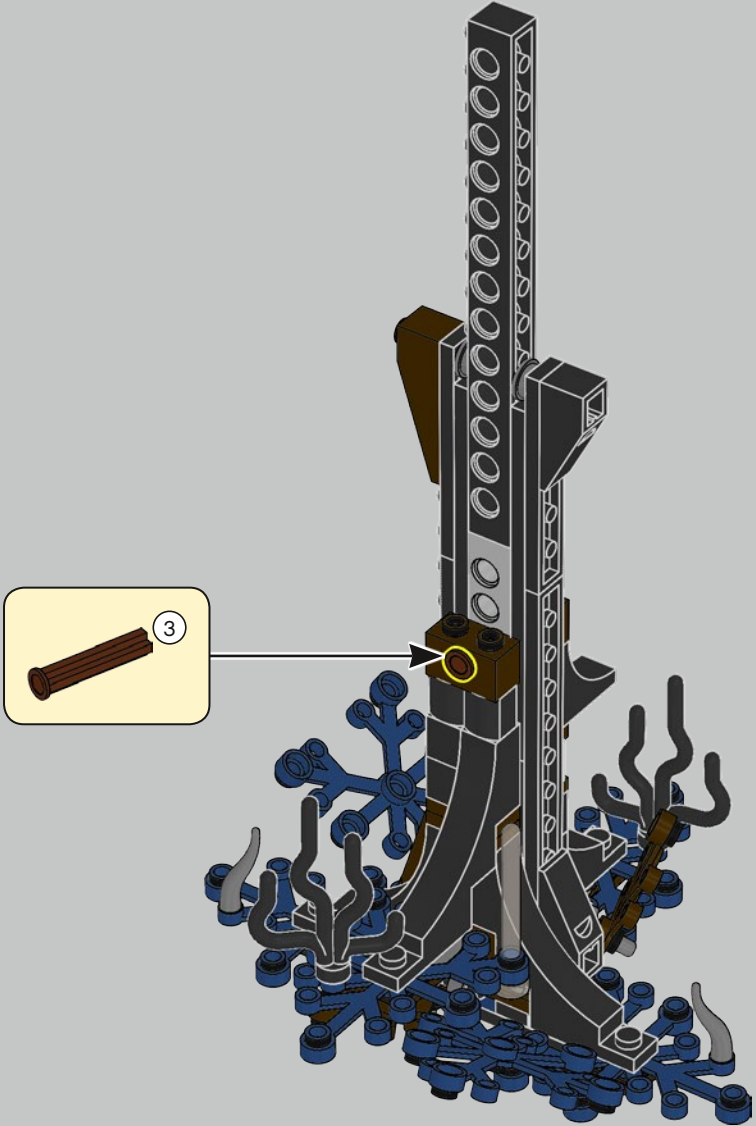



273

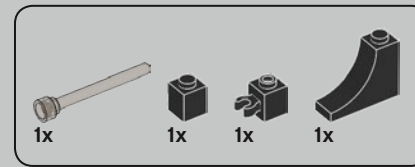
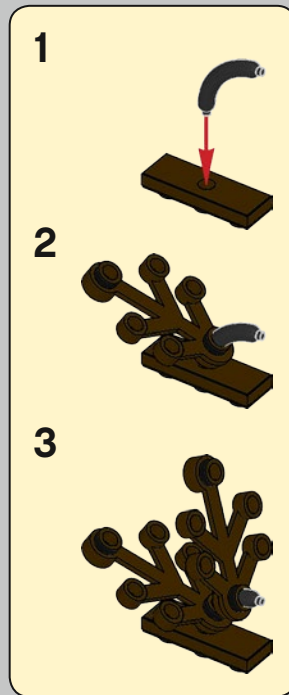
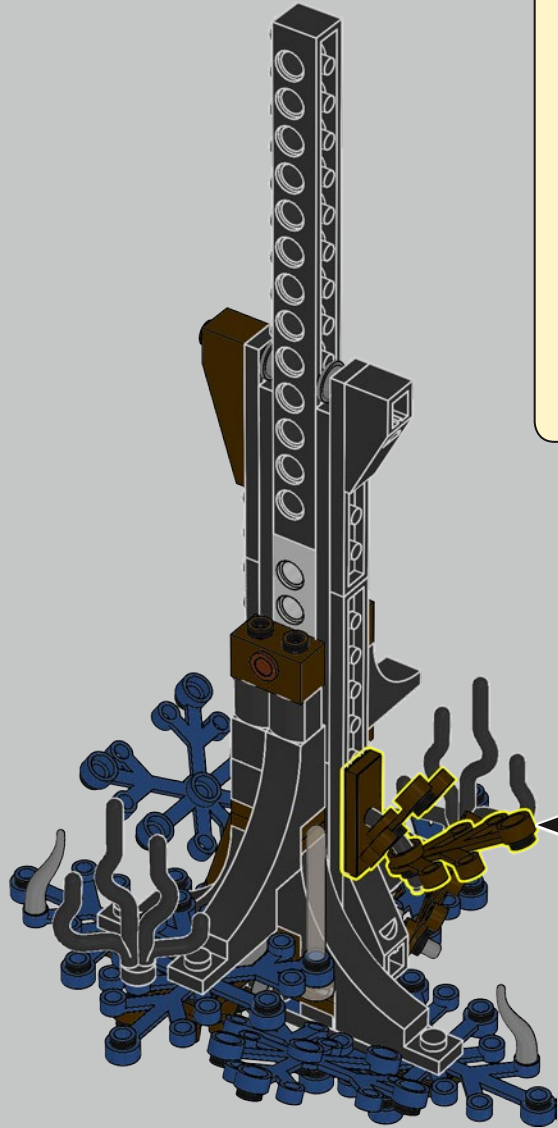

274

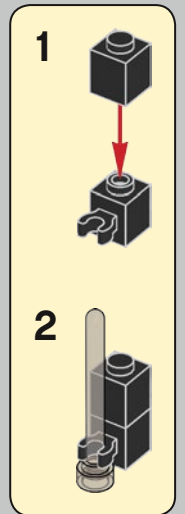
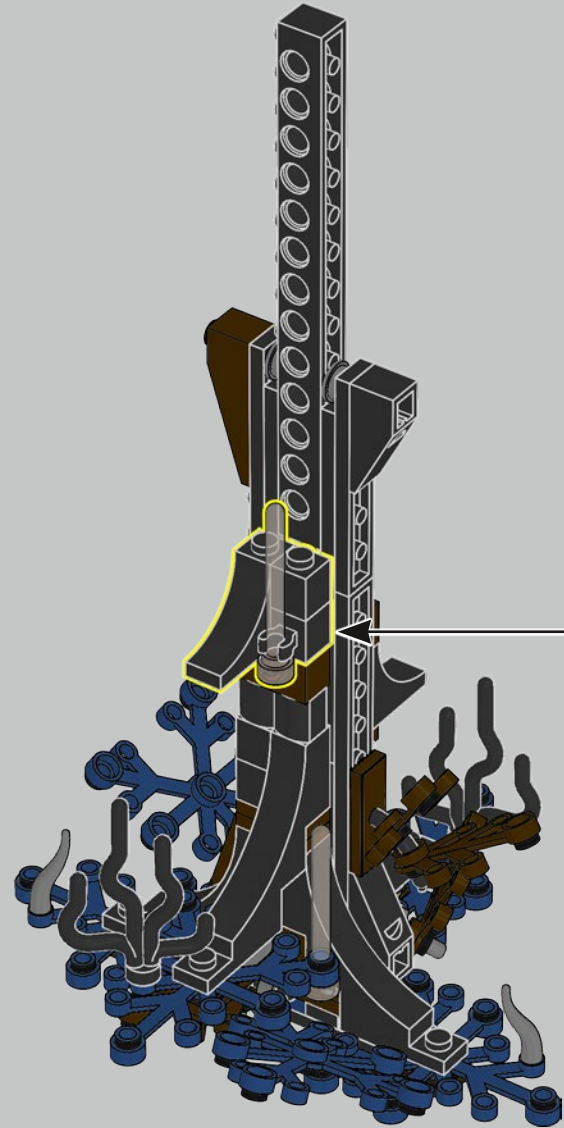

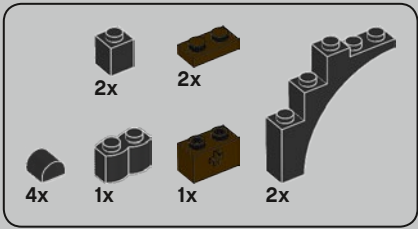

275

1

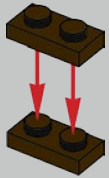

2

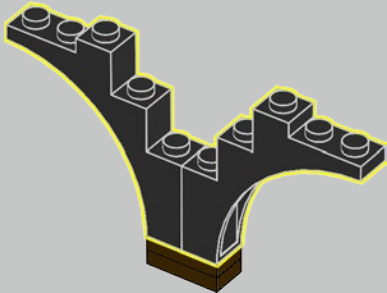

3

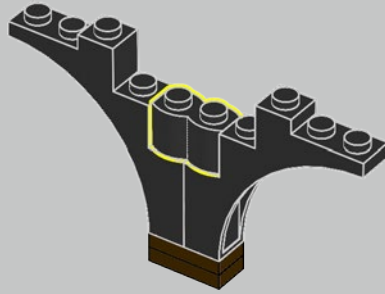

4

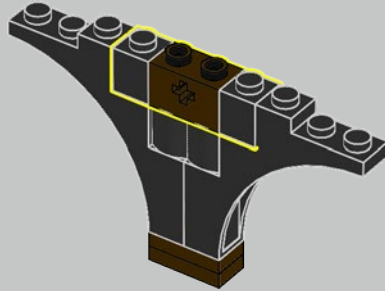

5

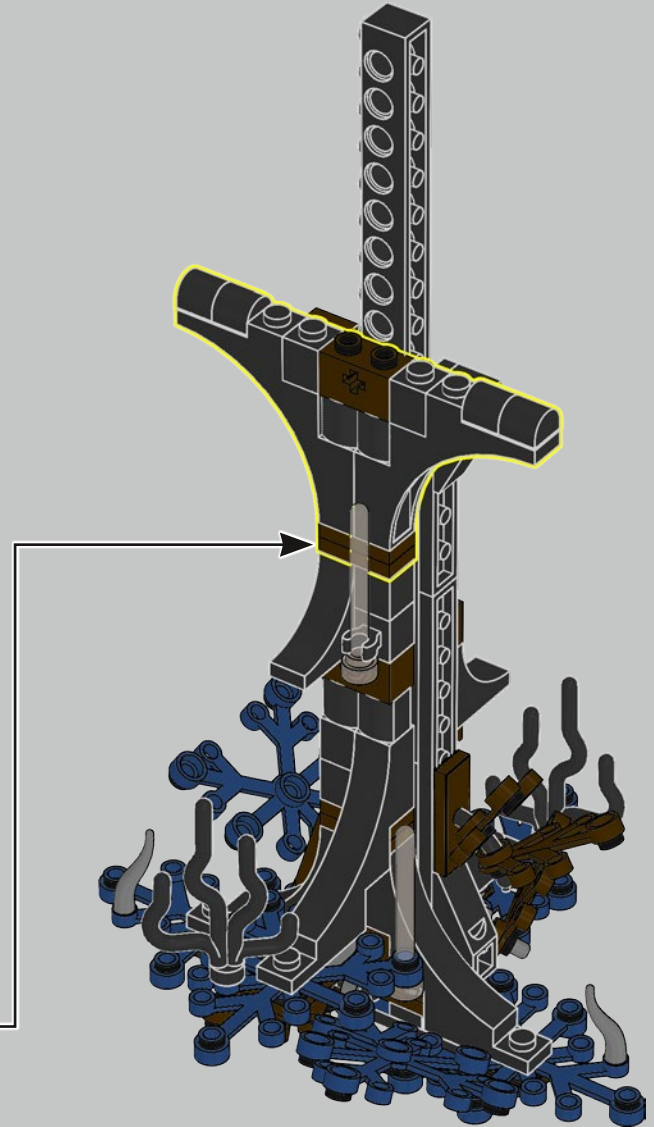
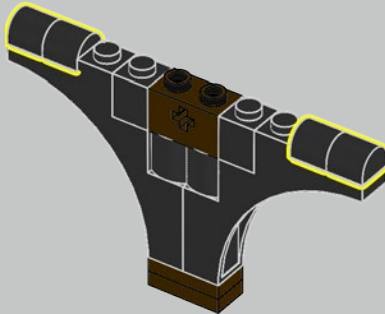

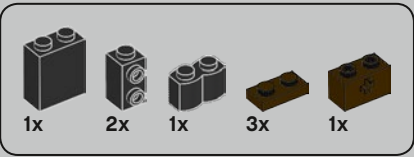

276

1

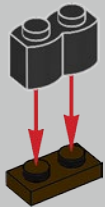

2



3



4

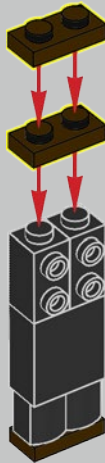

5

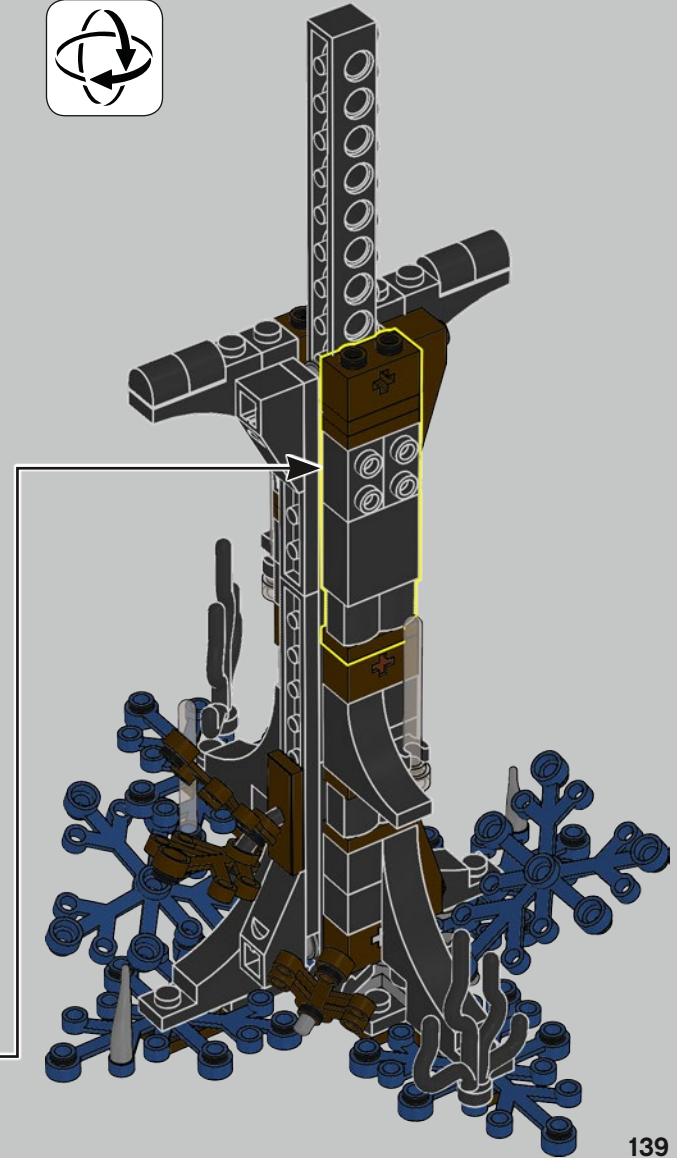
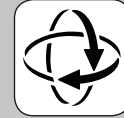

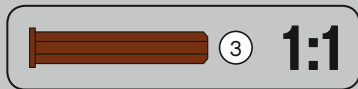
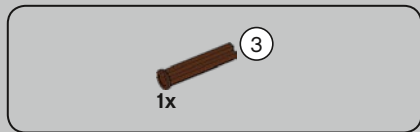

277

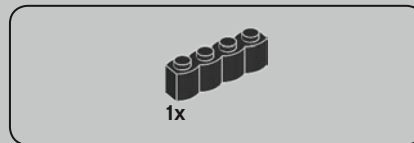
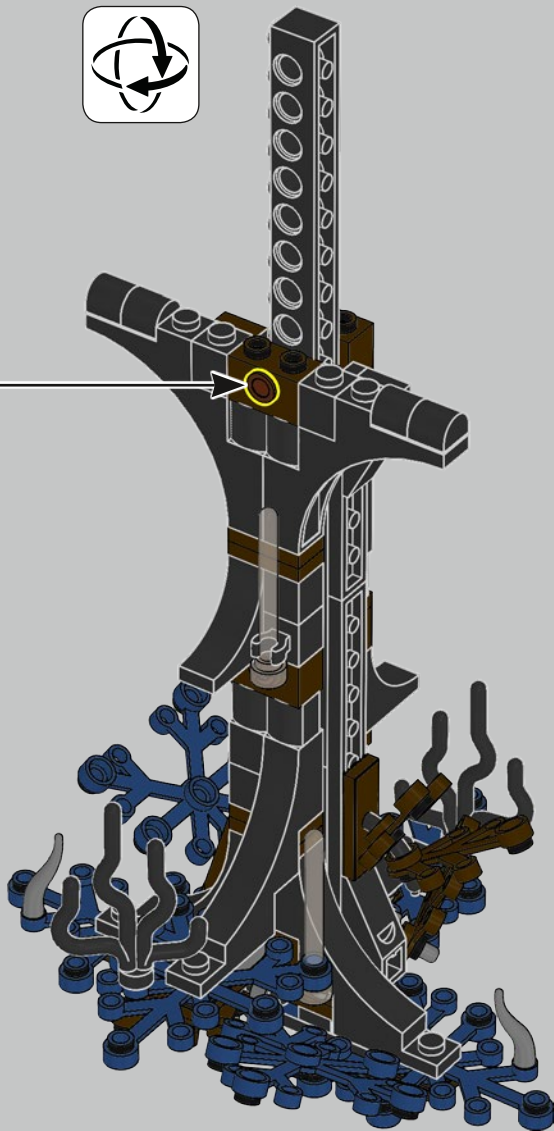
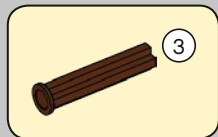

278

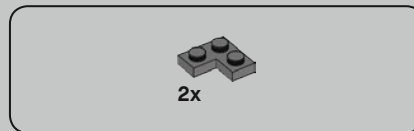
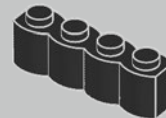

279

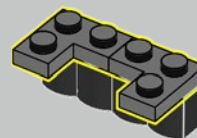

280

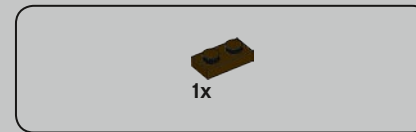
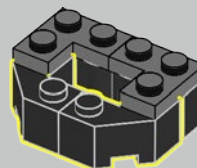

281

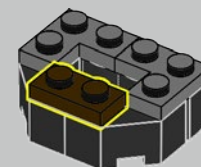

282

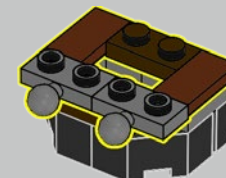



283

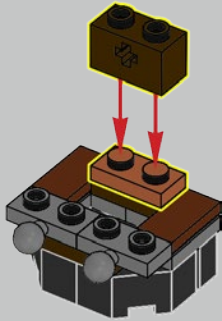

284

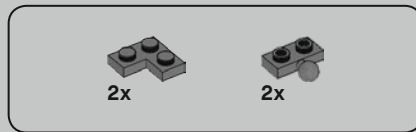
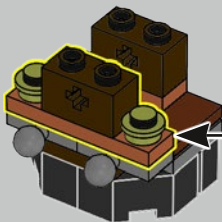
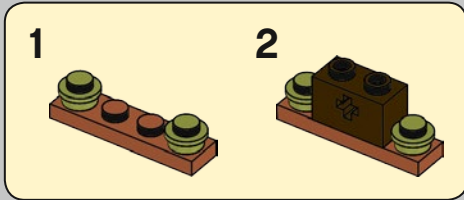

285

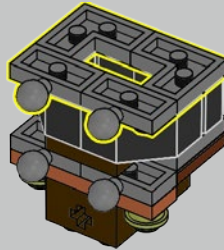

286

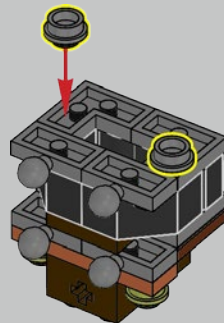

287

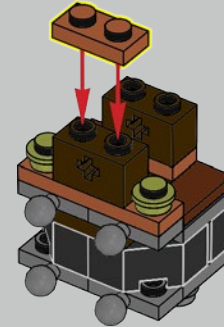

288

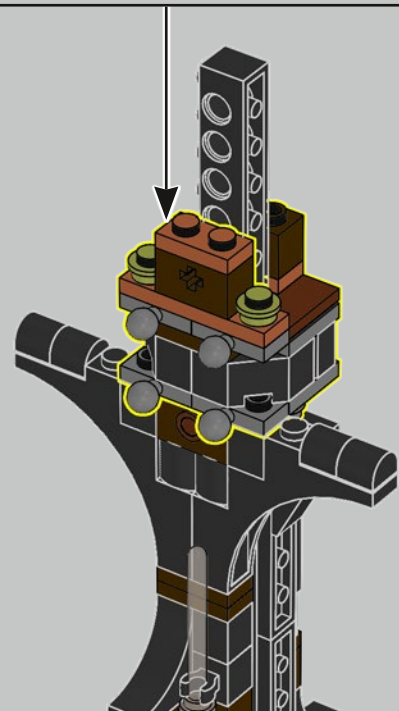

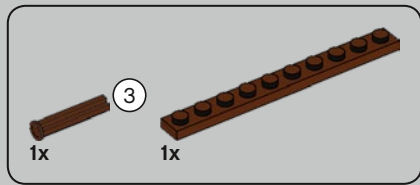

289

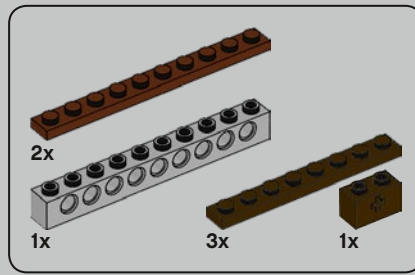
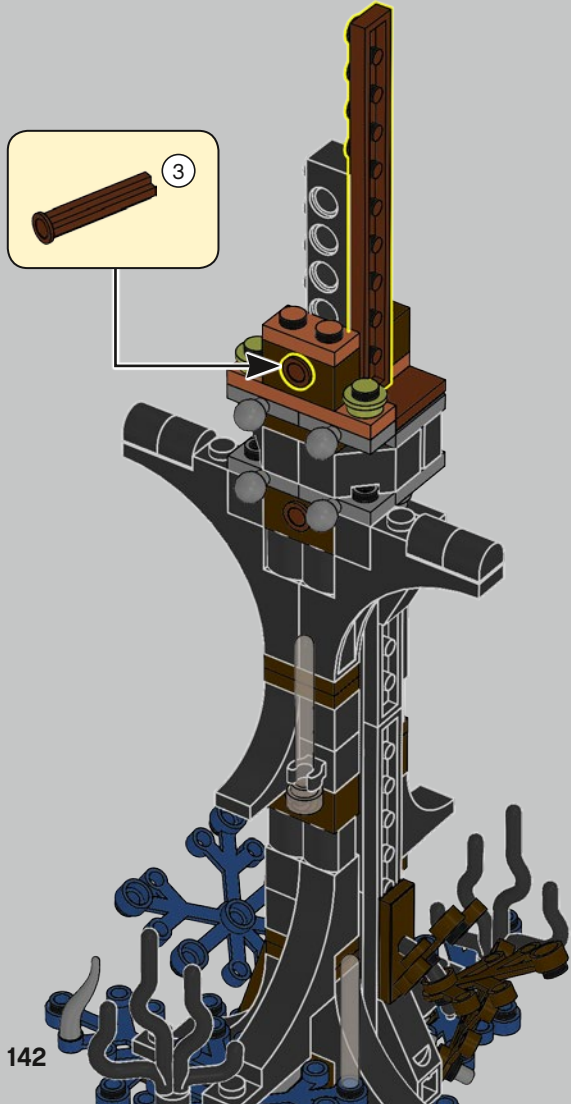
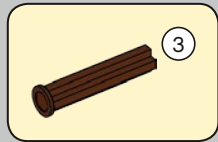

290

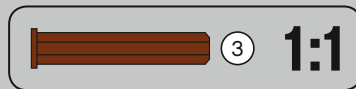

1

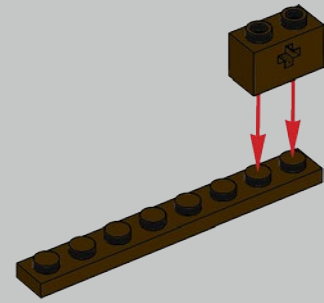

2

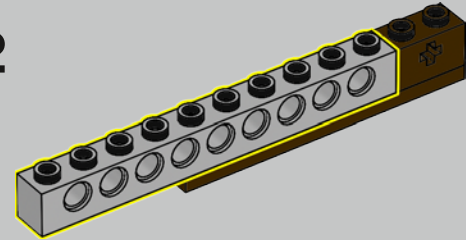

3

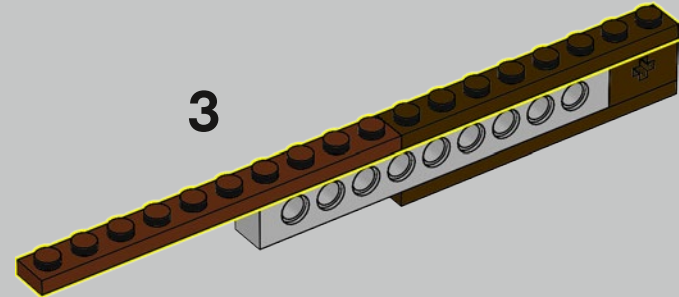

4

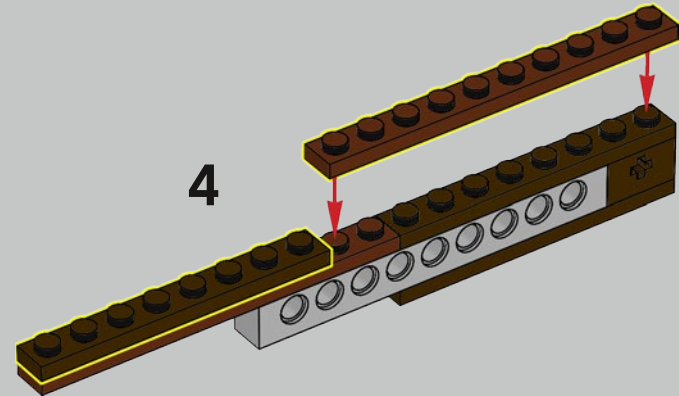

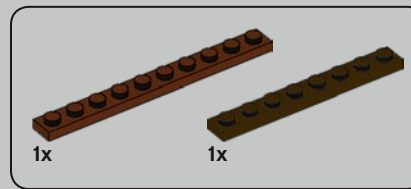
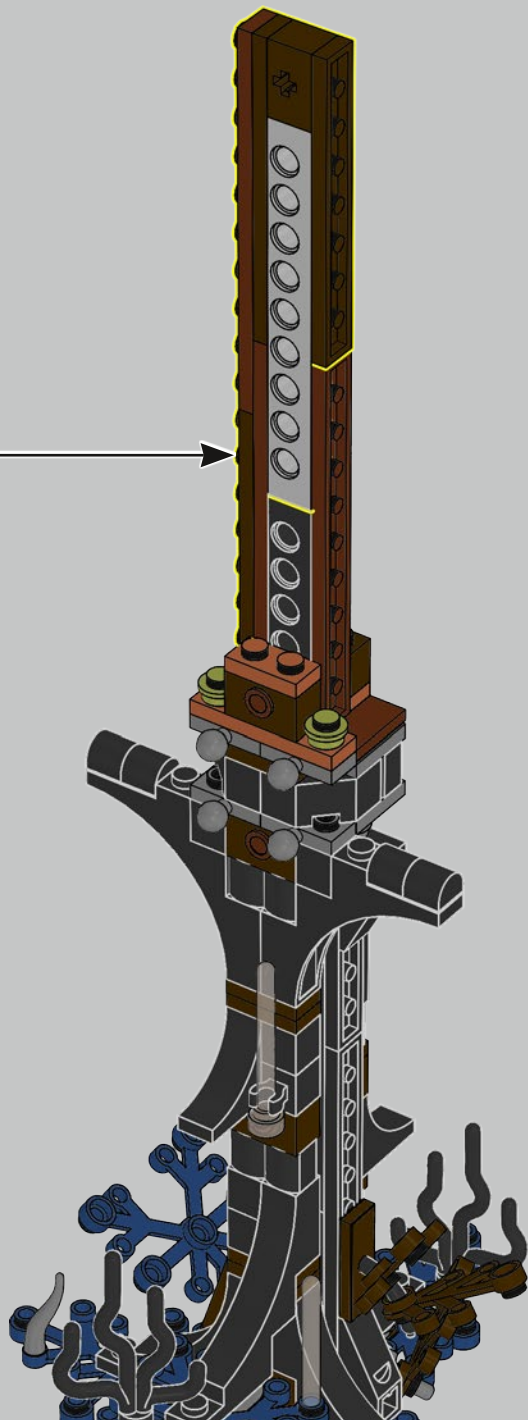

291

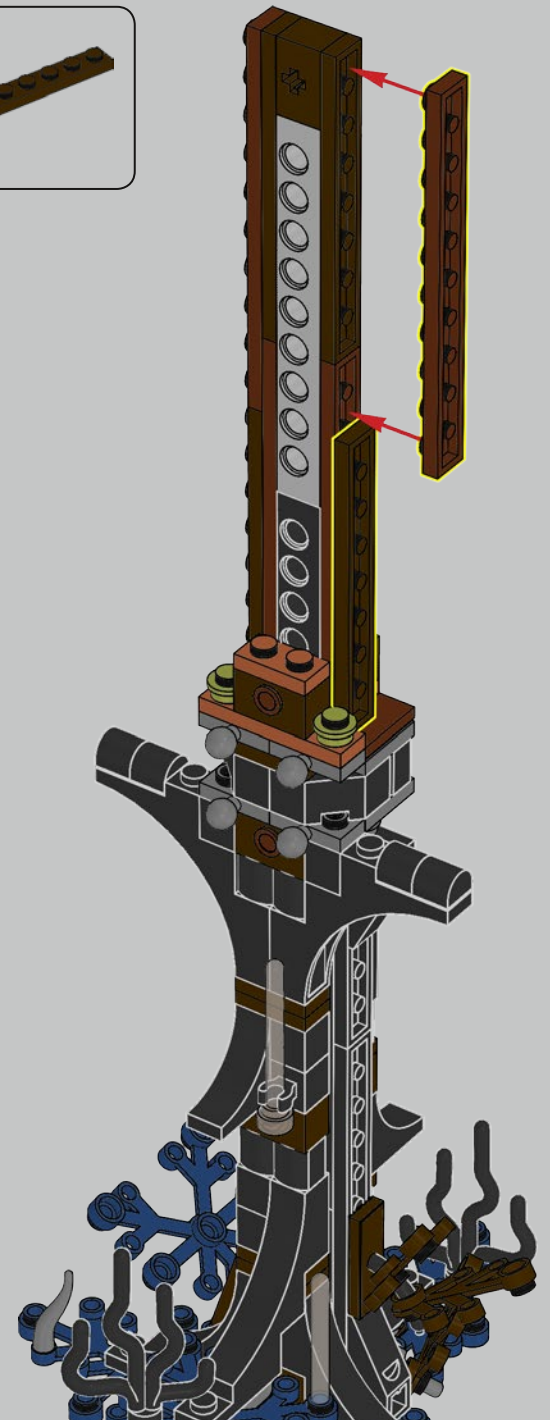

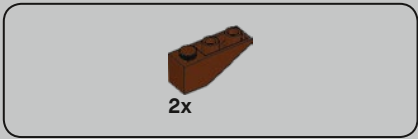

292

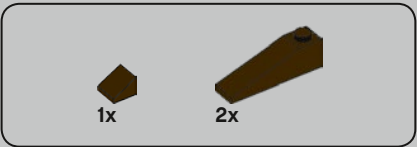
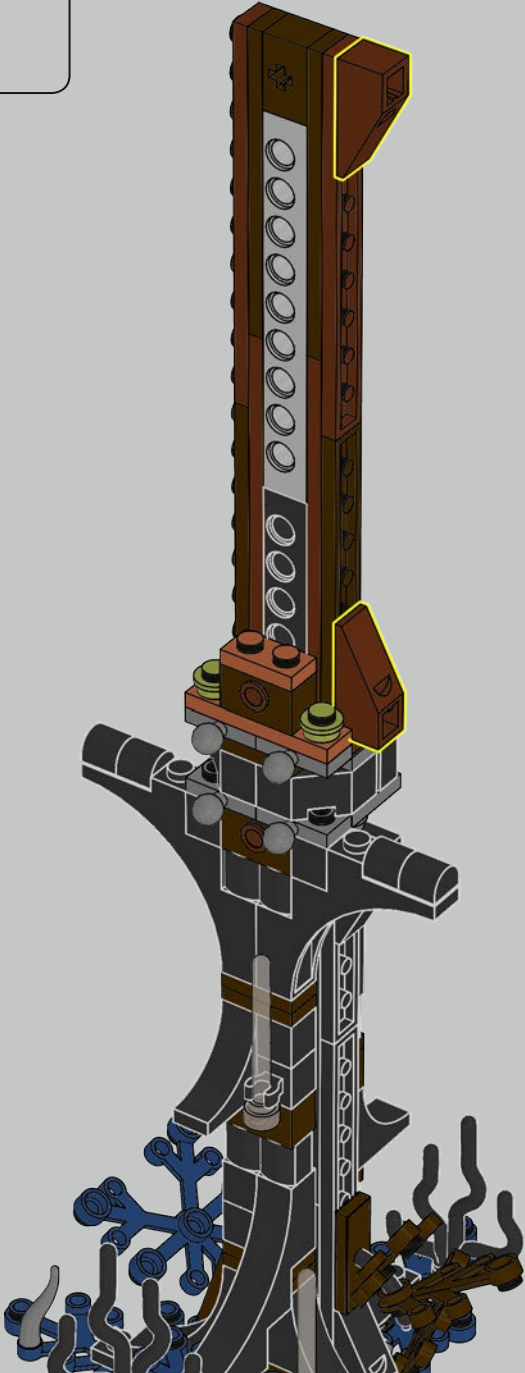

293

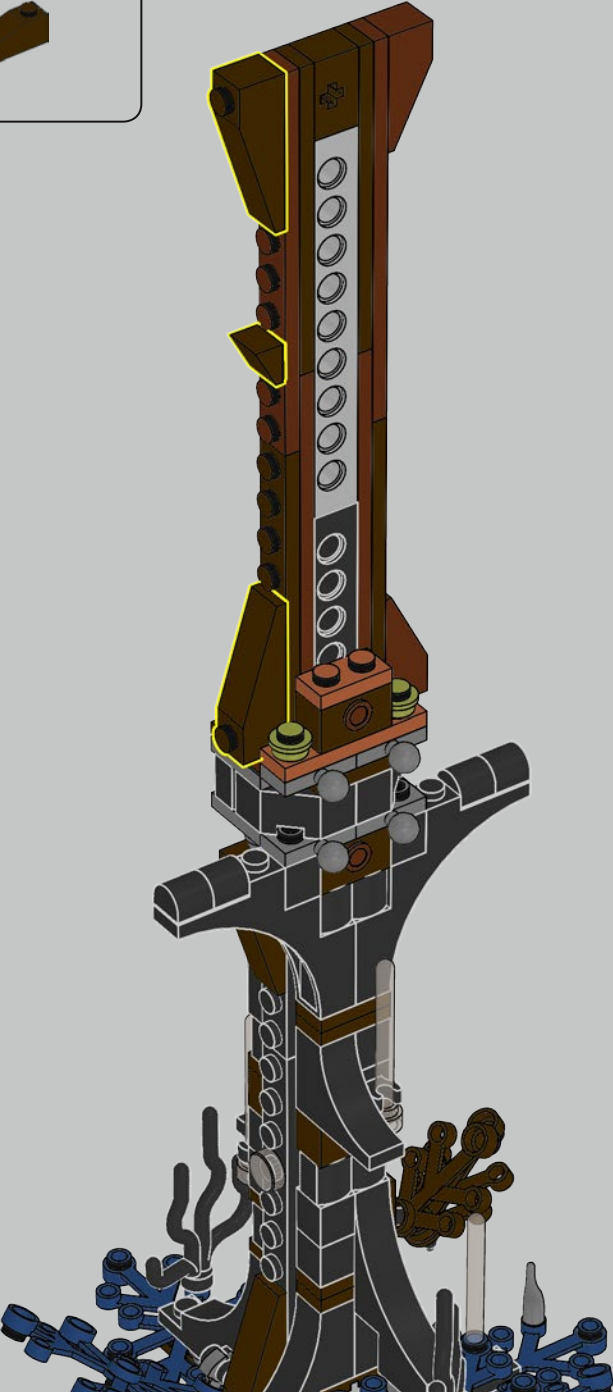

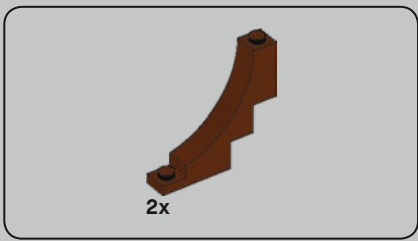

294

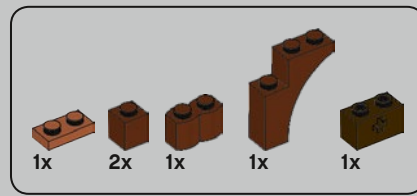
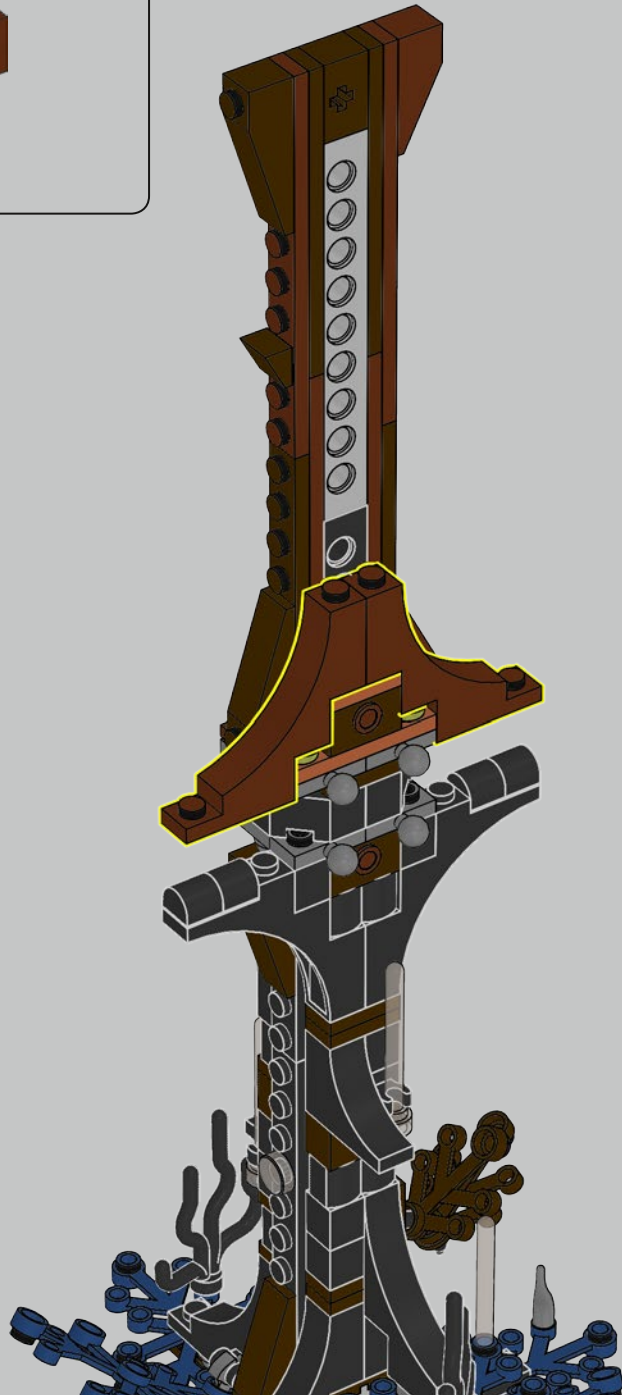

295

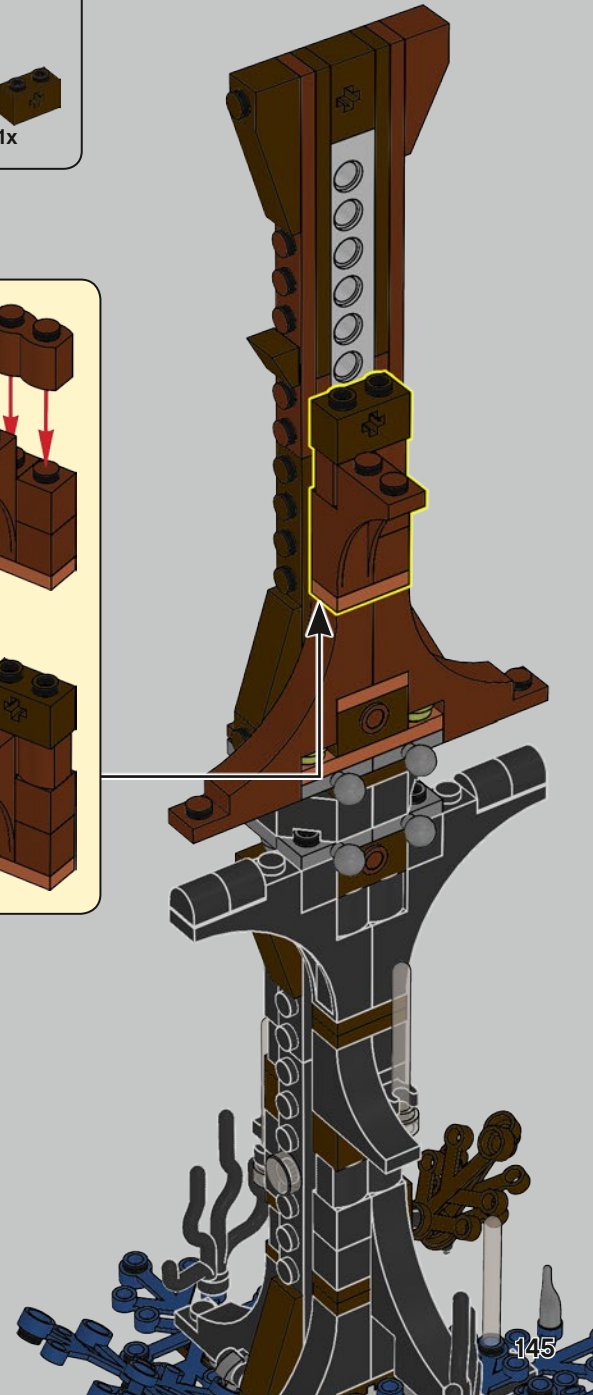
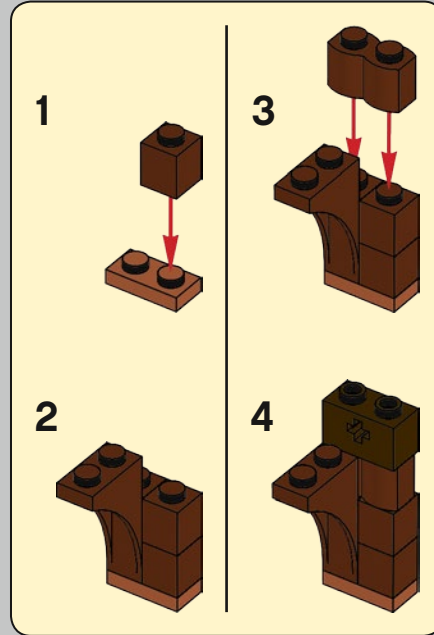



2x

296

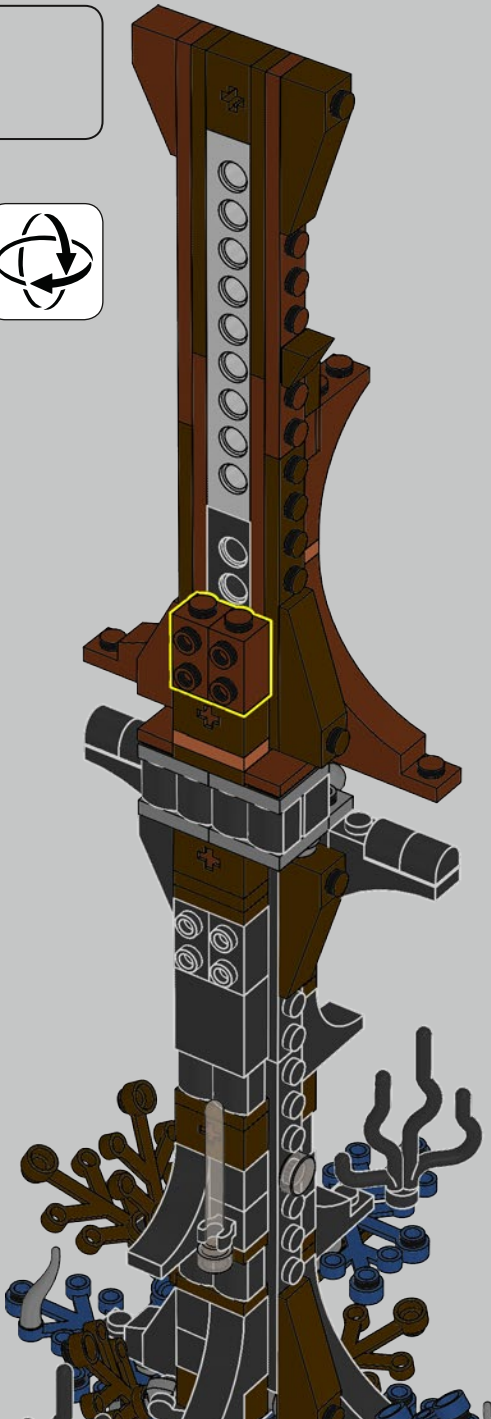

1x

2x

1x

1x

1x

297

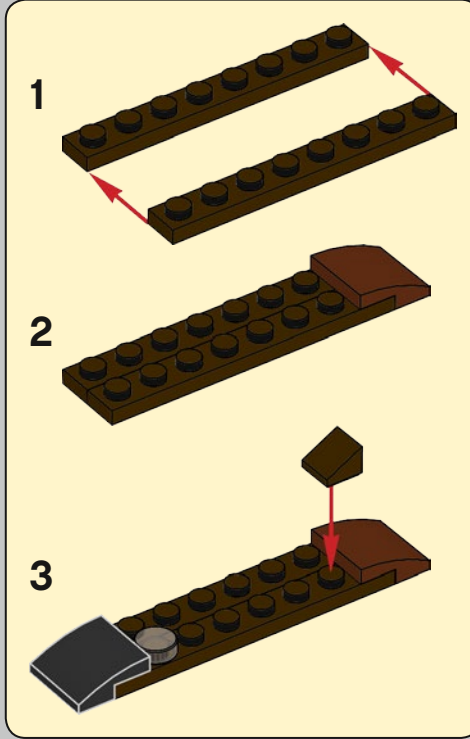

1

2

3

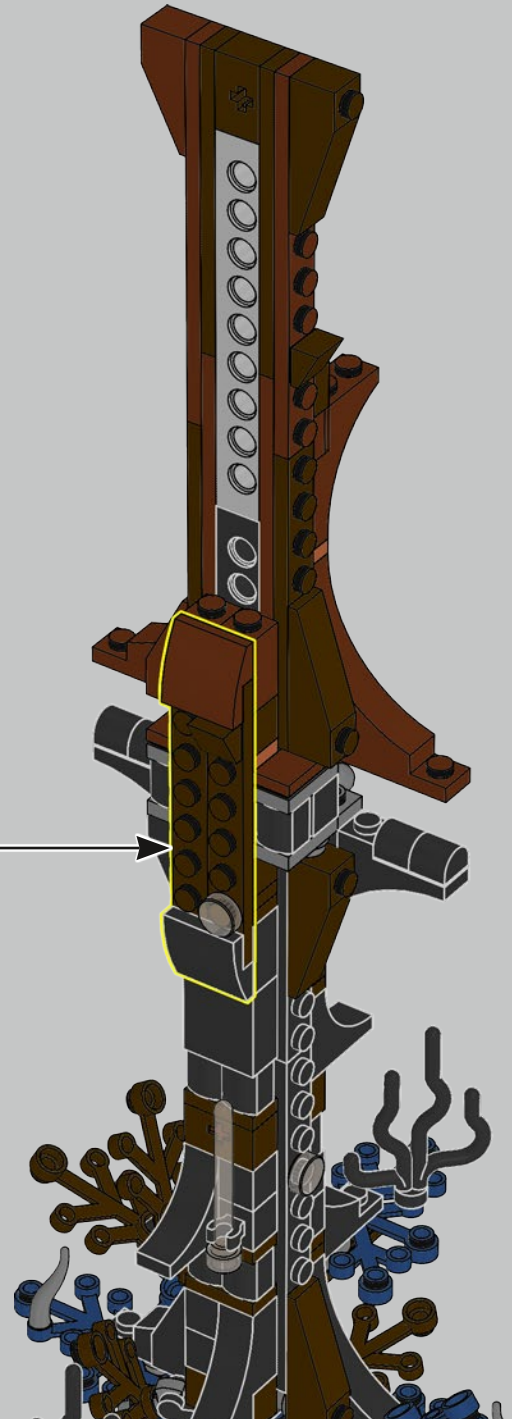

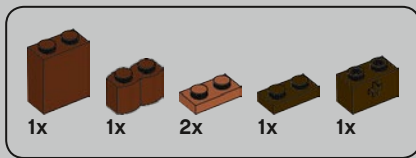

298

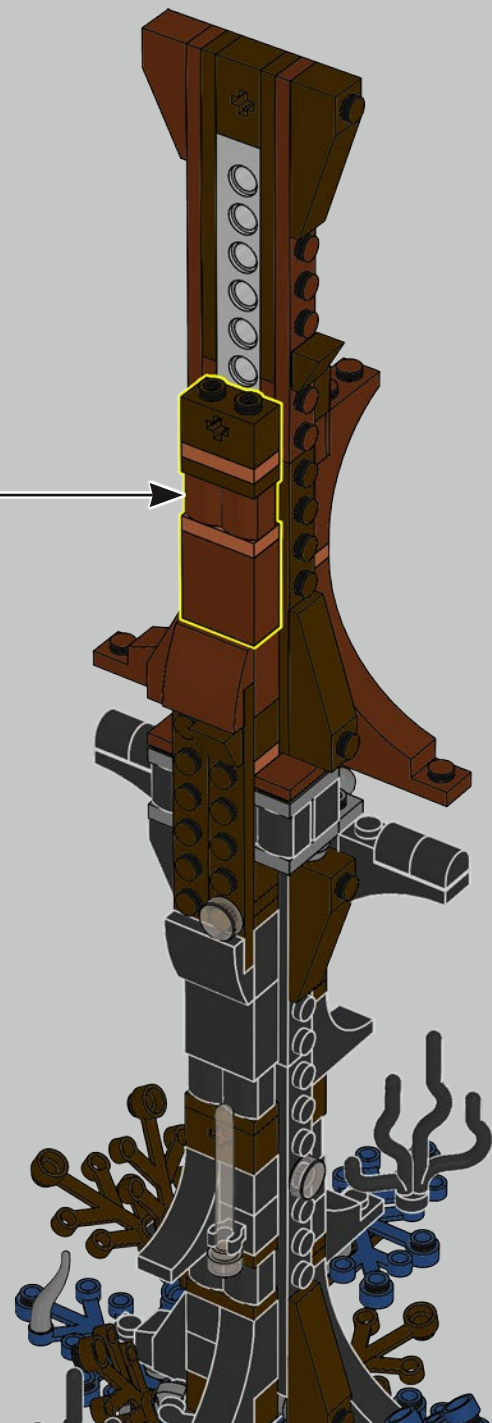
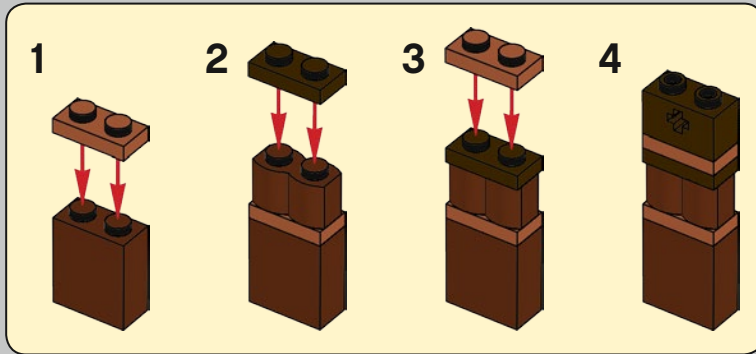

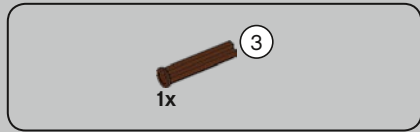

299

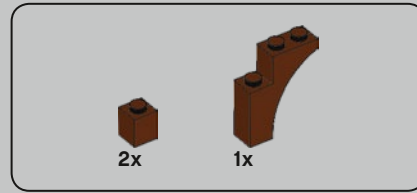
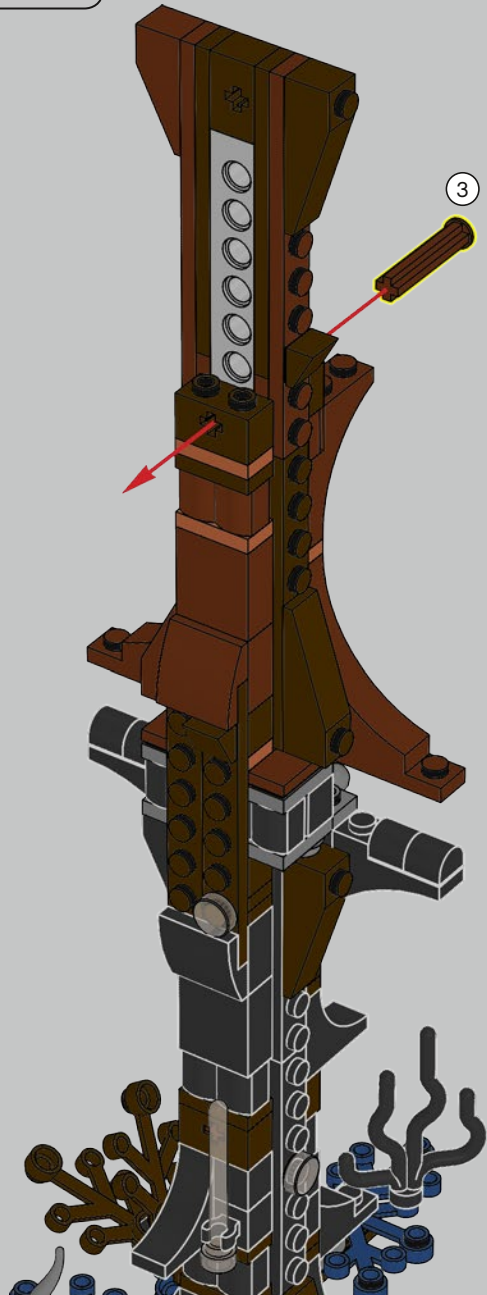
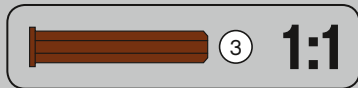

300

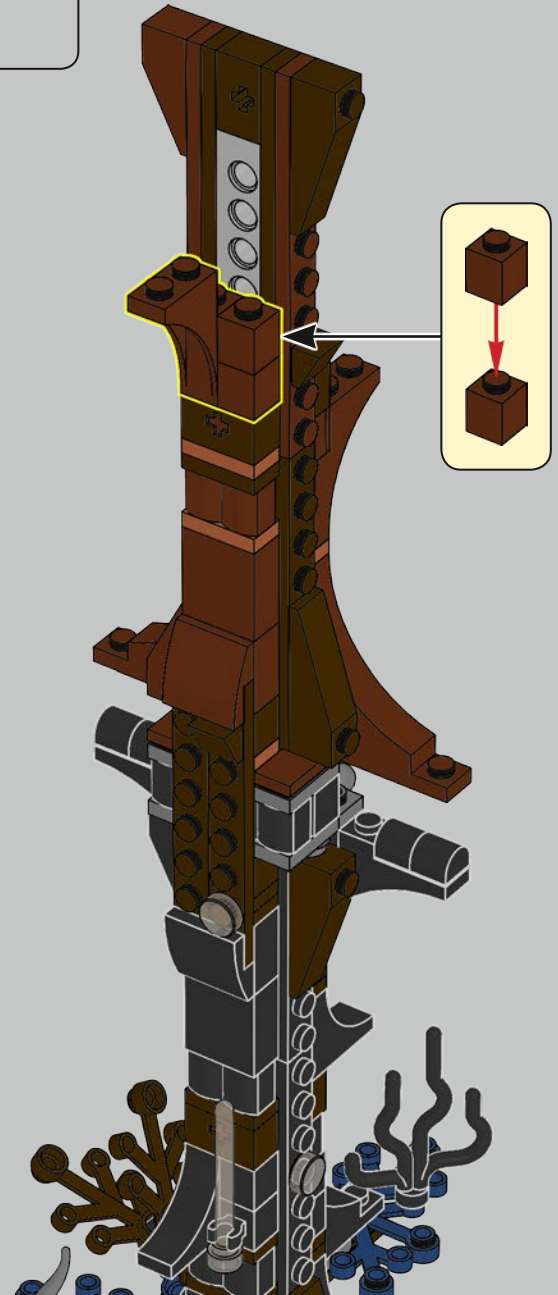

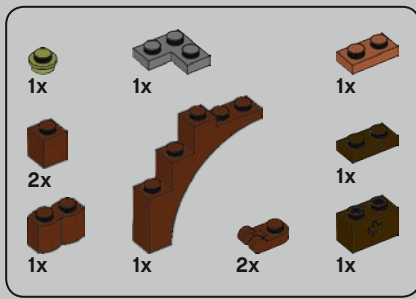

301

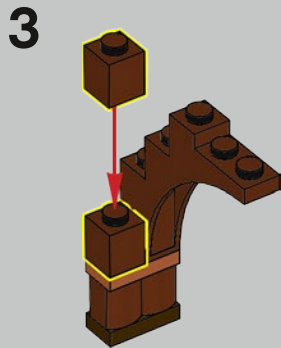
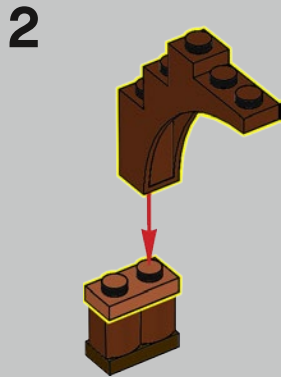
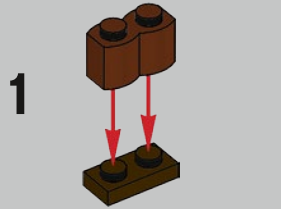

4

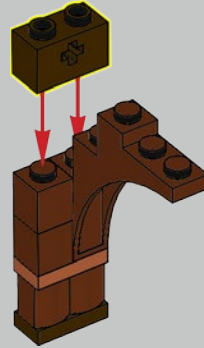

5

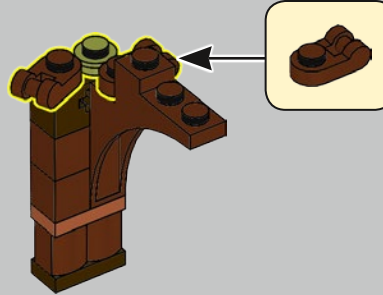

6

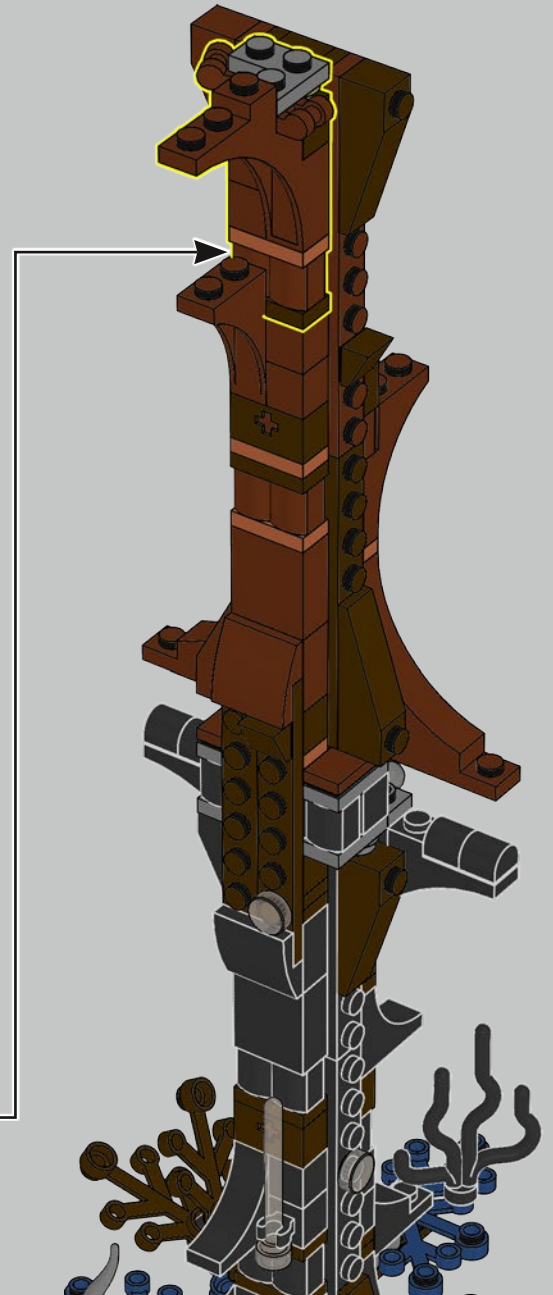
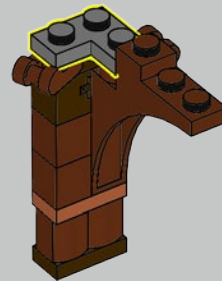

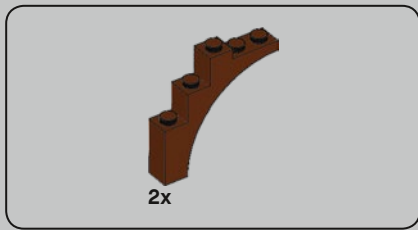

303

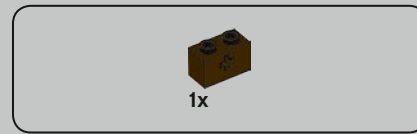
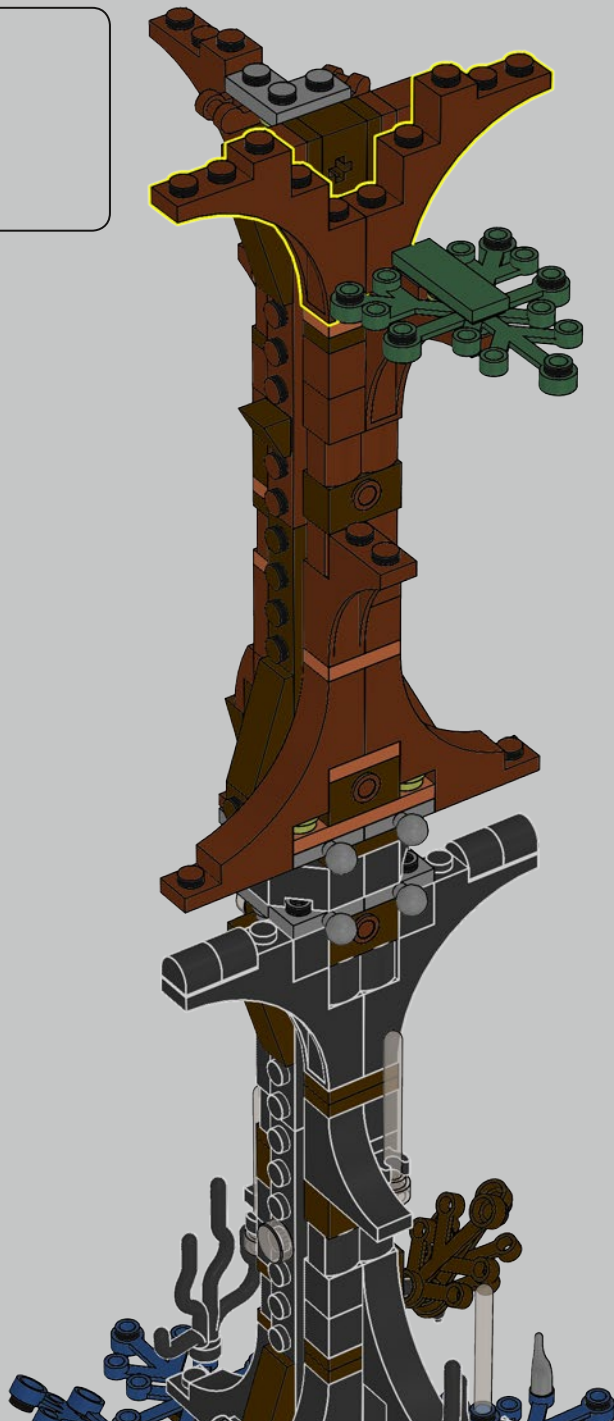

304

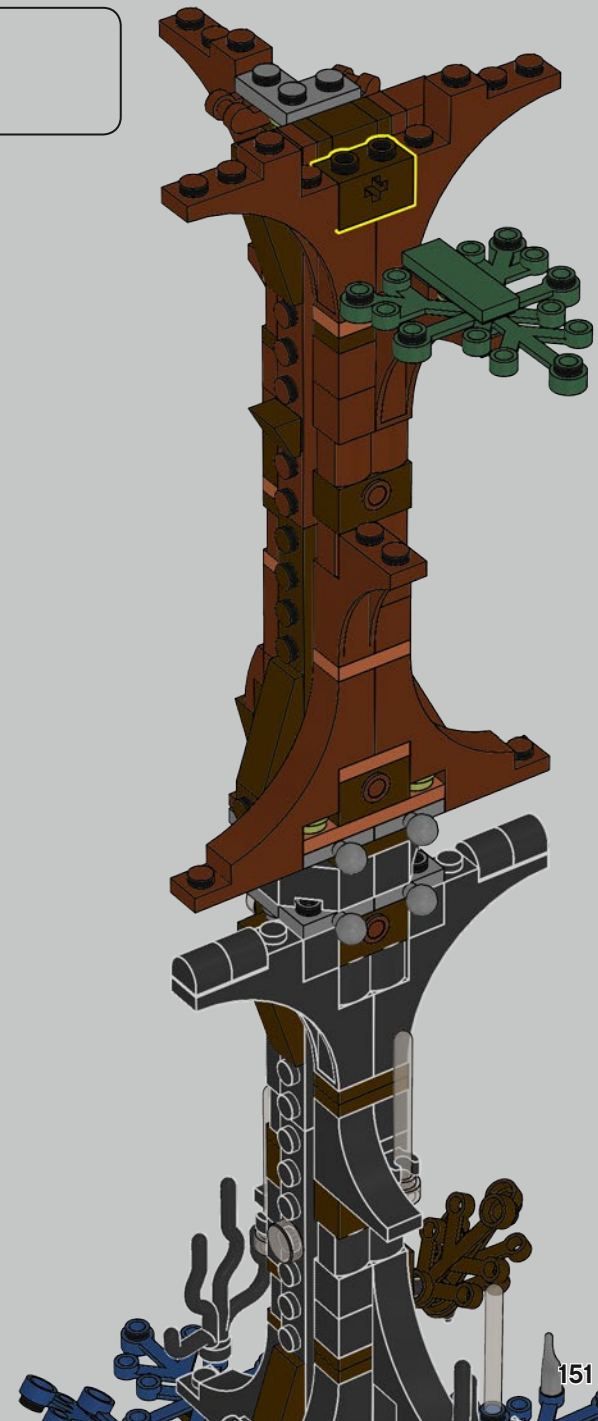

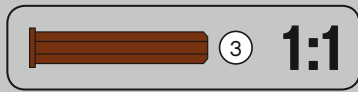
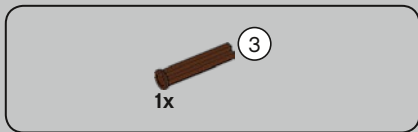

305



306

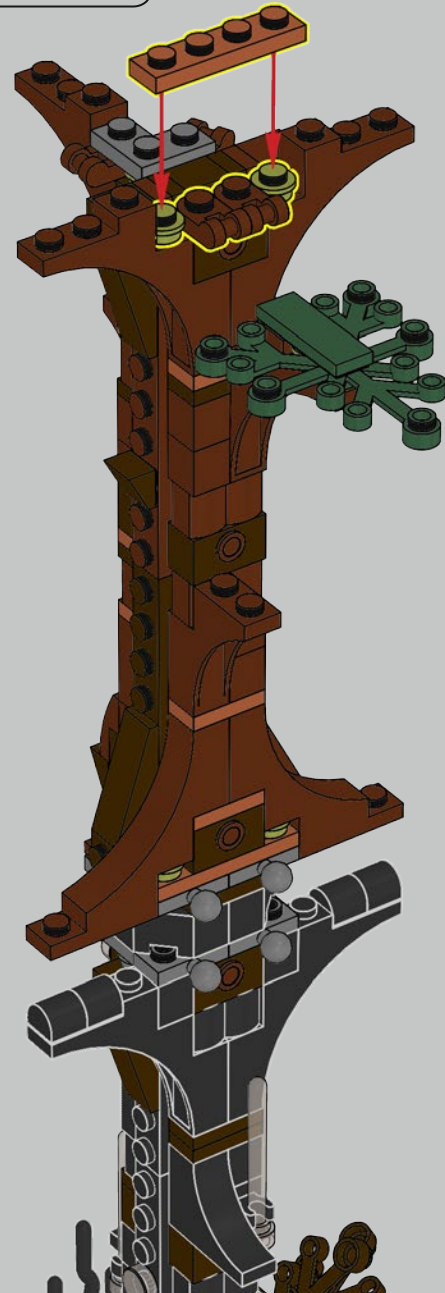

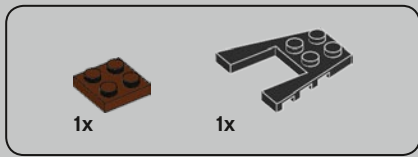

307

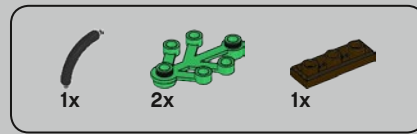
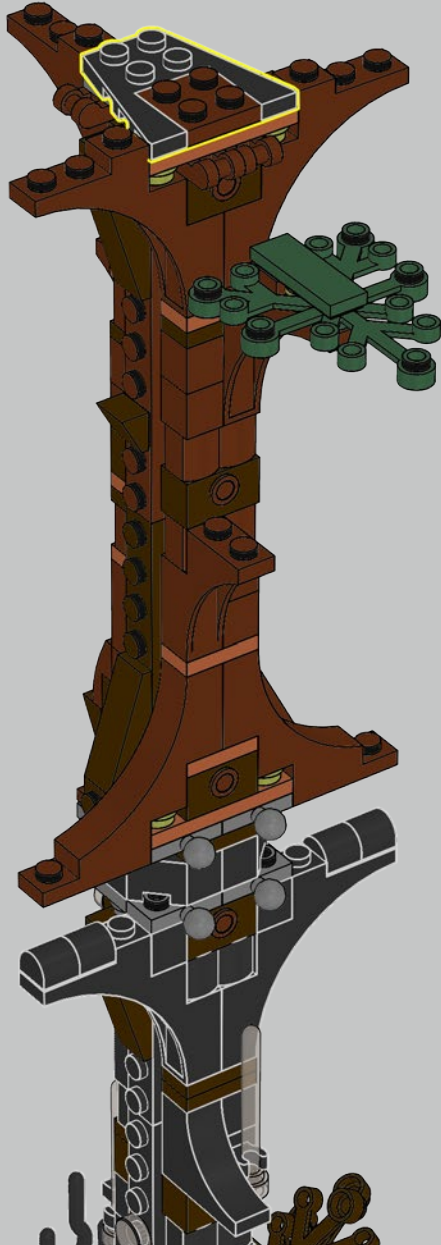

308

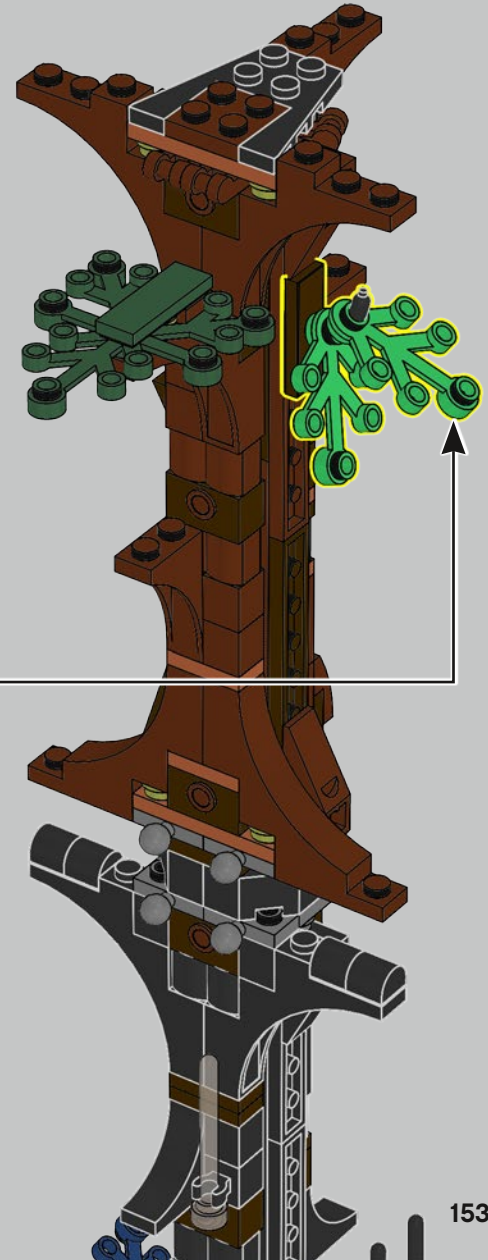
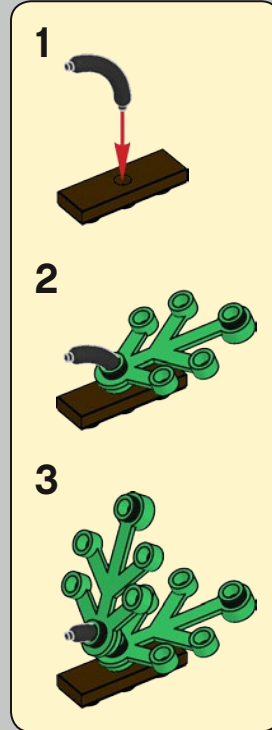



309

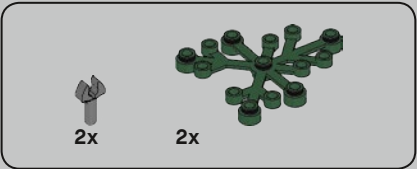
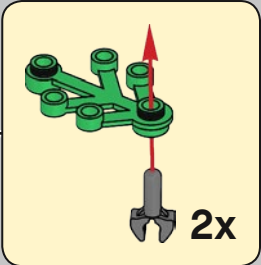

310

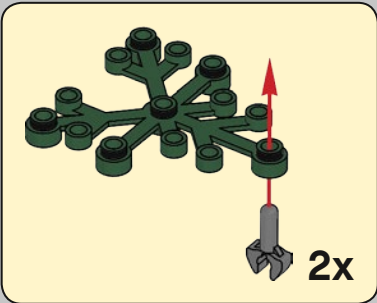

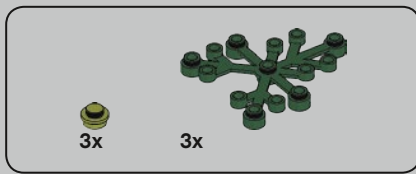

311

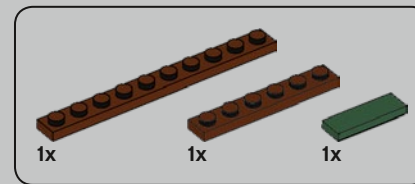

312



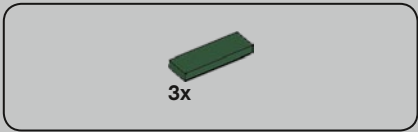

313



2x

314

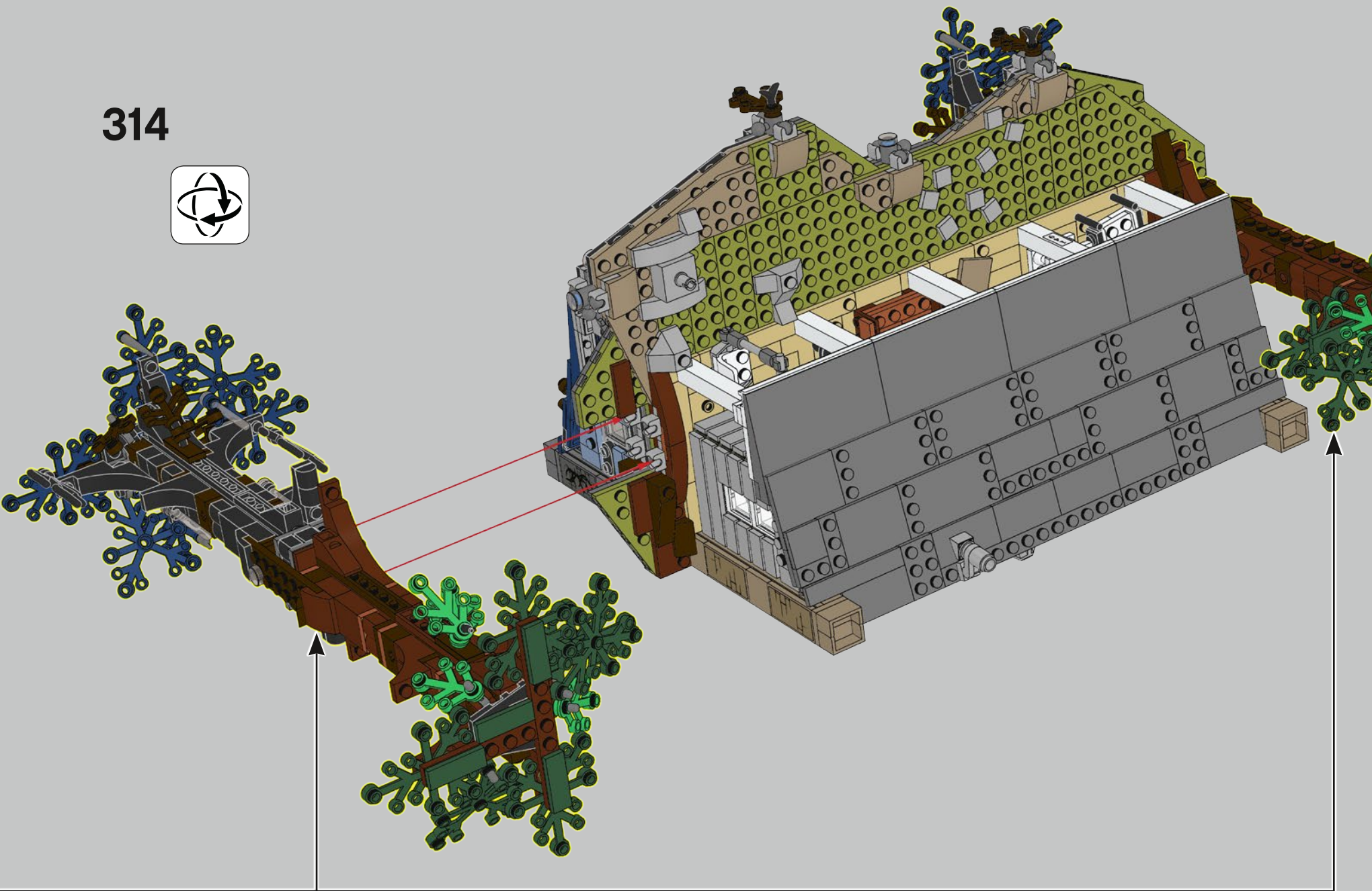

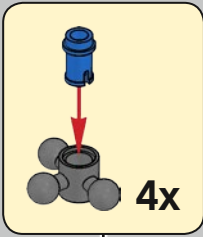
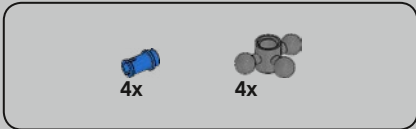

315

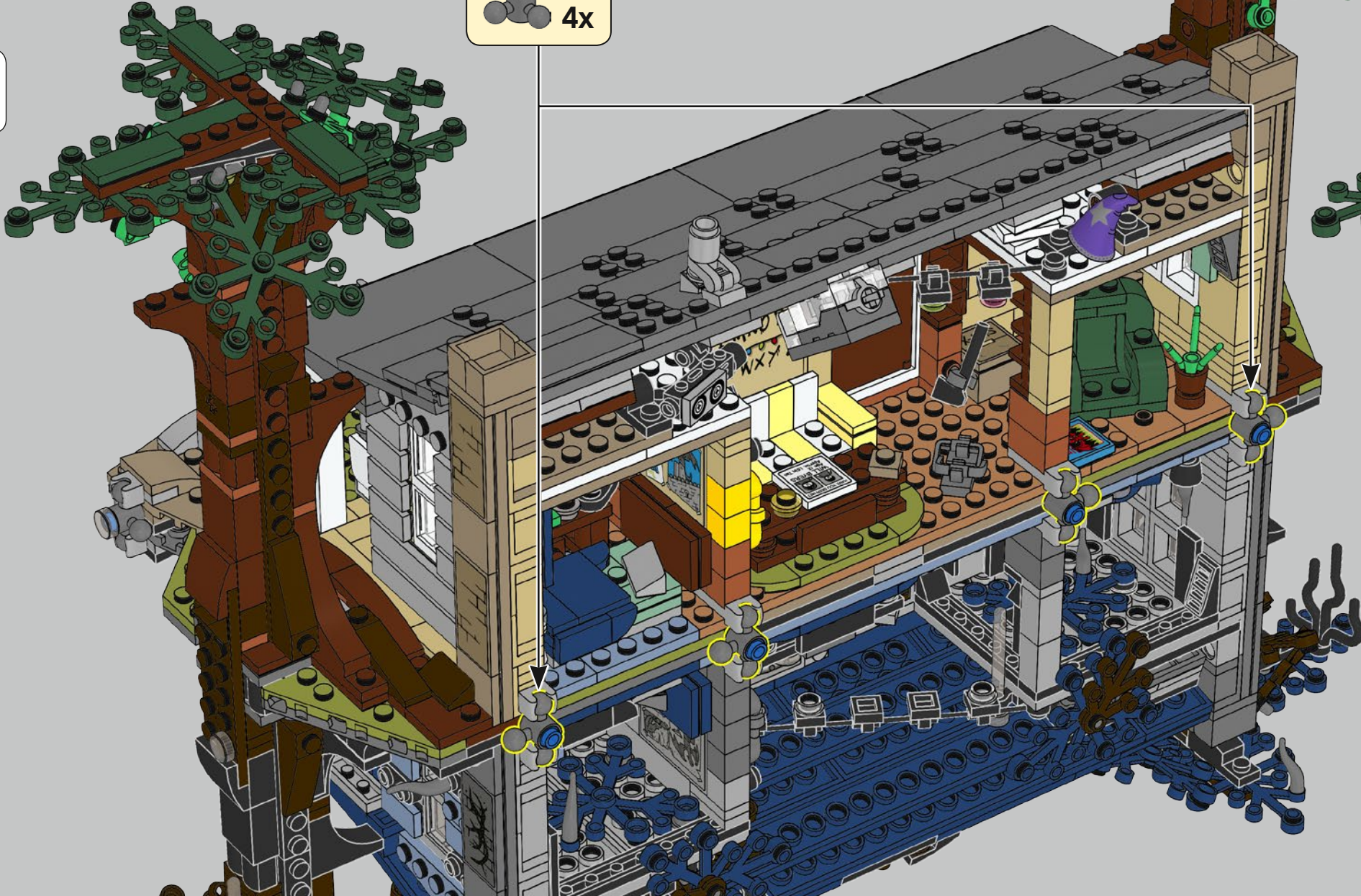

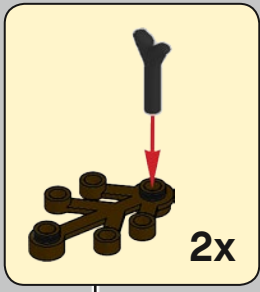

316





317

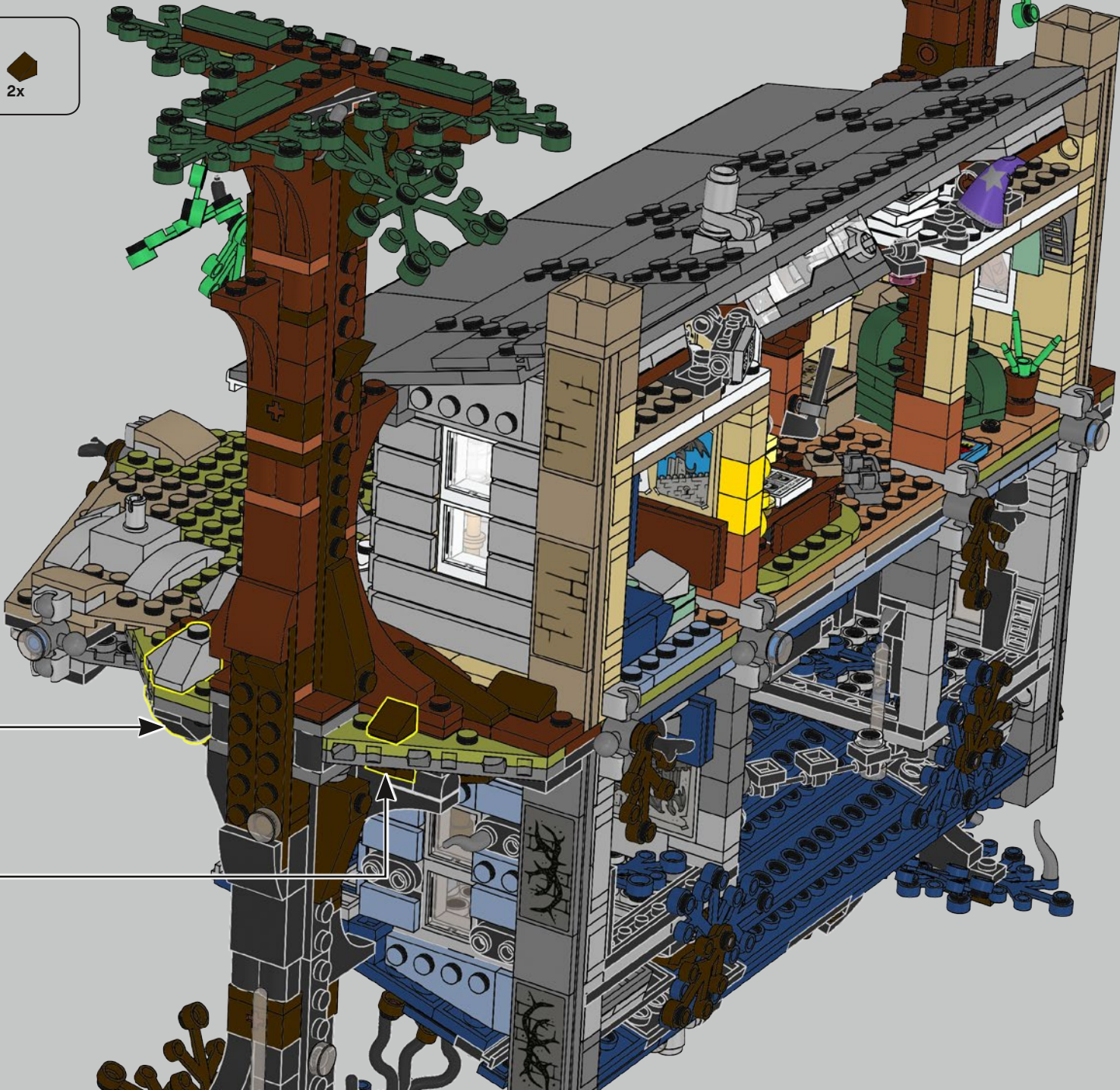

		
1x	1x	2x

318



319



12

22





1x 4518400	2x 6126046	1x 6228969	2x 4523145	5x 6173056	1x 6170421	4x 6228987	8x 6114987	3x 300326	4x 383926
2x 6168642	2x 306801	3x 6058014	4x 6092587	13x 4201062	3x 4598897	1x 6271080	3x 302326	12x 242026	2x 6230228
4x 459901	1x 6061201	5x 6061201	32x 6024495	6x 4113233	4x 6156414	4x 4541191	1x 4541191	13x 6052126	3x 371026
2x 302401	2x 407901	1x 6179744	3x 4159279	1x 4113916	4x 6015891	9x 4214559	2x 6115086	2x 362226	1x 4162443
5x 245301	2x 362301	1x 6195265	10x 4113917	1x 4113916	8x 6186646	8x 6092585	8x 6092585	11x 362326	4x 6037746
1x 4659665	2x 302101	1x 6201646	2x 6249809	1x 6272116	1x 6186675	1x 6138173	1x 6138173	4x 6154860	1x 615726
1x 6270843	2x 243101	1x 300524	2x 6117975	2x 6186258	8x 614126	5x 306926	5x 306926	4x 428726	1x 6174917
2x 4515370	2x 371001	1x 4515354	8x 6174925	2x 4114309	4x 6203937	4x 4533771	4x 4584274	4x 428726	4x 302026
3x 302301	1x 6262945	1x 6272114	5x 4565387	4x 4124067	2x 6170545	1x 6233020	4x 6000650	11x 4558170	1x 300126
5x 6051511	3x 346001	5x 302124	5x 6221467	1x 4112982	4x 459926	3x 6070695	2x 4107761	4x 6162541	2x 6092878
2x 6070712	2x 416201	1x 6275511	5x 6173057	9x 4157277	5x 302426	10x 4644456	2x 4535739	4x 6272148	1x 6272100
4x 306901	4x 4500878	8x 4159553	4x 4114077	1x 6272112	8x 6273589	7x 6272138	12x 6053077	1x 383526	4x 6075062
14x 4521210	3x 303501	2x 4118793	4x 4114077	3x 6156462	7x 6172383	2x 4515340	7x 6192346	6x 306826	1x 6272100
2x 6023804	4x 4500878	2x 4118793	4x 4514554	1x 6272112	10x 4504382	4x 6174243	6x 306826	2x 6211476	4x 6162892
2x 6070698	3x 303501	14x 4579260	4x 4514554	3x 6156462	15x 6066102	16x 6047276	2x 6211476	2x 368026	5x 302126
1x 6274904	2x 4503008	4x 6232135	1x 4162465	7x 6131896	2x 307026	2x 4618852	2x 6176768	2x 6176768	8x 4116854
		6x 6275973			6x 407026	4x 4569733			
					16x 300526				

2x 292626
 4x 4561035
 1x 6076678
 1x 4143180
 11x 366626
 6x 4243819
 11x 379526
 1x 4653049
 3x 346026
 1x 303426
 9x 447726
166

11x 4667595
 2x 4252437
 2x 4508313
 4x 6229005
 22x 6272134
 7x 6236568
 4x 6247207
 5x 6120642
 1x 4161067
 2x 4107558
 1x 428226
 2x 6096958

7x 4184108
 3x 6199890
 7x 4528981
 6x 4528488
 4x 6115447
 3x 6037890
 2x 4205004
 4x 6199898
 2x 4528482
 1x 6273588
 2x 4177735
 2x 6186974
 5x 4530028
 2x 6103985
 2x 4502089
 7x 4569836

6x 4143232
 4x 6062686
 1x 6207944
 1x 6207945
 4x 6198156
 21x 6142505
 2x 6062089
 2x 6057880
 4x 6142245
 12x 6262031
 8x 6111685
 4x 6248957
 9x 6262030
 1x 6272127

8x 4143005
 2x 6240214
 1x 6251289
 1x 6205087
 1x 6270846
 1x 6275518
 2x 4622574
 1x 6226541
 2x 4621554
 1x 6268630
 1x 6074793
 1x 6259921
 1x 6245192

2x 6223655
 3x 6274738
 6x 6186867
 7x 6240030
 4x 6254254
 8x 6254552
 1x 6277089
 1x 6274803
 29x 6079000
 6x 6278255
 8x 6254564
 2x 6253217
 4x 6240219
 9x 6280166
 1x 6253684
 1x 6245192

2x 6270334
 1x 6271074
 4x 4549436
 4x 6040126
 1x 6265367
 1x 4524098
 2x 4521914
 4x 6228921
 2x 4528604
 4x 6275132
 1x 6274864
 2x 6275485
 3x 6028018
 1x 6252771
 6x 4507045

2x 6047415
 4x 6093038
 1x 6126075
 3x 4255416
 1x 6270990
 4x 6015452
 1x 6271064
 4x 6035540
 4x 6164288
 1x 6258403
 5x 4550329
 2x 6156492
 4x 6275088

1x 6173138
 1x 4666322
 2x 6254484
 3x 6186012
 3x 4579659
 4x 4614158
 17x 4570877
 5x 6074892
 2x 6074893
 4x 4535928
 2x 6000743
 5x 6253418
 2x 6252040
 1x 6267125
 2x 6193782
 1x 6240515

8x 4216581	2x 6226436	1x 4211201	1x 6206150	1x 6170418	2x 4211389	1x 4226995	5x 6065824	5x 6257593	3x 4211425
1x 6186673	2x 6146858	2x 6097417	1x 6269971	1x 4539481	4x 6225242	2x 4211541	4x 6034676	2x 4622803	4x 4211404
1x 6173143	3x 4216695	4x 6044725	1x 4565321	2x 4211412	9x 4213567	25x 4211414	2x 4211815	1x 6272132	4x 4211404
1x 6271066	4x 6196221	8x 6044725	8x 6268814	2x 4211525	2x 4594238	3x 4211564	8x 6043639	1x 6064030	4x 4222019
1x 4626196	2x 4211257	2x 4270882	6x 6184432	2x 4211525	2x 6225246	32x 6015344	2x 4211804	1x 6064030	4x 4222019
16x 4211242	10x 6135494	2x 4270882	2x 4655080	1x 6168647	6x 4533772	2x 4611702	1x 4654577	1x 6064030	1x 6014617
2x 4225469	6x 6100769	3x 4221590	1x 4616578	2x 6252203	1x 6057487	14x 6146300	1x 4211428	1x 4211569	4x 4211374
4x 4645400	1x 4211220	6x 4243838	1x 6223171	1x 6057487	5x 4211399	6x 4654582	2x 4211429	1x 6015347	2x 4211407
4x 6201911	4x 4211195	2x 4211247	4x 6202626	9x 4521921	14x 4558953	2x 6117967	2x 6138216	1x 4211444	2x 4211407
2x 4211288	4x 6055086	1x 4216945	3x 6055169	1x 4211732	4x 4211735	8x 4654580	19x 4558169	1x 4211444	1x 4514846
8x 6153863	1x 6234159	2x 4271874	1x 6270888	4x 4211764	1x 4568637	2x 6093527	1x 6278504	8x 6256117	1x 4211393
10x 4211180	1x 6248918	1x 4211211	7x 6013102	1x 4568637	2x 4540203	5x 6126082	1x 4211396	1x 4211393	17x 4211549
1x 6234159	4x 6045941	2x 4223683	4x 4588024	2x 4540203	16x 6043656	1x 4211397	4x 4211356	1x 4211396	2x 4211402
2x 6172808	1x 4579690	10x 4223683	1x 4538760	2x 4219913	2x 4219913	7x 6212077	10x 4211445	1x 4211396	2x 4211402
3x 4211150	1x 4211186	12x 6266967	10x 4650622	1x 6061702	1x 6275294	1x 4211413	13x 4211445	14x 4211438	4x 4211486
4x 4211151			2x 4650244	4x 6061702	1x 6275294	1x 4211413	2x 4211452	2x 4211452	
2x 6133860			12x 6266967	8x 4211415	4x 6061702	1x 4211413	2x 4211452	2x 4211452	
				1x 4211362	1x 4211362	1x 4211413	2x 4211452	2x 4211452	

- 4x 6015890
- 1x 4529240
- 24x 4210633
- 4x 6231765
- 19x 4289542
- 5x 4210719
- 4x 4211098
- 2x 6071226
- 4x 6228923
- 2x 6245283
- 2x 6221607
- 1x 4580437
- 1x 4567887
- 1x 4540386
- 4x 6275131
- 8x 4211063
- 2x 6117972
- 2x 6000606
- 8x 6055629
- 2x 4543086
- 1x 4210676
- 10x 6269080
- 2x 4210883
- 2x 4210635
- 2x 4210651
- 5x 4211056
- 2x 6115080
- 7x 4211088
- 8x 6039479
- 2x 4211039
- 1x 6126083
- 2x 4211094
- 2x 6013082
- 8x 4211055
- 12x 4210635
- 2x 4210651
- 5x 4211056
- 2x 4211100
- 4x 4509911
- 6x 6199511
- 10x 4210997
- 4x 6262023
- 4x 4654618
- 5x 6133611
- 1x 4211122
- 1x 4259673
- 4x 4211067
- 3x 4654613
- 2x 4524930
- 1x 4521886
- 6x 4211043
- 3x 4211001
- 1x 4211053
- 11x 4560184
- 6x 4211065
- 2x 4509884
- 2x 6266298
- 1x 6266299
- 8x 6259071
- 1x 6270953
- 1x 4623298
- 4x 6127366
- 1x 6270913
- 1x 4529672
- 28x 6272144
- 28x 6058221
- 1x 4538950
- 3x 6199910
- 14x 6272145
- 1x 6272143
- 22x 6272141
- 4x 6252667
- 14x 4519742
- 12x 4519946
- 2x 6240206
- 1x 6240216
- 2x 6240230
- 2x 6177146
- 8x 6218358
- 4x 6021997
- 2x 6102994
- 4x 6056383
- 2x 6177535
- 3x 6273197
- 4x 6102998
- 8x 6167700
- 2x 6218359
- 2x 6102995
- 1x 6272111
- 6x 4633691
- 7x 4619636
- 4x 6208446
- 1x 6271175
- 1x 6271118
- 1x 6271173
- 1x 6277193
- 1x 6271121
- 1x 6271098
- 1x 6271089
- 1x 6158415
- 2x 6254248
- 1x 6251290
- 18x 6258990
- 4x 6218089
- 5x 6020144
- 1x 6272104
- 2x 6272103
- 8x 6273296
- 4x 6272101
- 3x 6272108
- 1x 6270987
- 1x 6271076
- 1x 6271109
- 1x 6271112
- 1x 6271114
- 1x 6277175
- 1x 6274692
- 2x 303221
- 1x 4538126
- 1x 6093529



Customer Service
Kundenservice
Service Consommateurs
Servicio Al Consumidor
LEGO.com/service or dial

00800 5346 5555 :         

1-800-422-5346 :  